

# NEJ-900 PIEZO GYRO SYSTEM

# JR

JRPG900

## FEATURES

- Integrated design for easy installation/connection
- No moving parts for a nearly unlimited service life
- Linear dynamic range up to 720 degrees per second
- 10 times faster response time than mechanical gyros
- Remote proportional gain control adjustable from the transmitter
- Patented offset drift canceler
- Compatible with JR and Futaba systems

## SPECIFICATIONS

Operating Voltage:	4.8V
Operating Current:	40 mAh
Dimensions/Weight:	
Gyro Sensor:	40x42x36mm/56g
Remote Gain Controller:	30x22x9mm/8g
Dynamic Range:	0 - 720° per second

## INTRODUCTION

JR's latest Piezo gyro, the NEJ-900, utilizes a new state-of-the-art integrated design for easy installation, while retaining the same performance levels found in the previous JR NEJ-1000 Piezo gyro.

Unlike standard mechanical type gyros that use a motor, flyweights, bearings, etc., the NEJ-900 Piezo gyro system is totally free of moving parts that in time wearout, giving the NEJ-900 a nearly unlimited service life.

The NEJ-900 offers a true linear response of up to 720 degrees per second. The NEJ-900 is also 10 times more sensitive and has a faster response time than any current mechanical type gyro, making the NEJ-900 one of the highest performance gyros available.

It is important to note that the operational features of the NEJ-900 Piezo gyro are very different than that of a mechanical type gyro system. Many current settings, including the travel volume, exponential, dual rates, and tail rotor revolution mixing values, must all be changed from their previous normal settings in order to achieve the correct tail rotor/control surface response and maximum performance that the NEJ-900 has to offer.

It is not recommended that the NEJ-900 be installed and flown in a model that was previously set up using a mechanical type gyro without first readjusting the function values as described in these instructions.

Carefully read these instructions so that you will fully understand and become comfortable with the functions and operating characteristics of the NEJ-900 prior to installation and initial test flights.

## CONNECTIONS

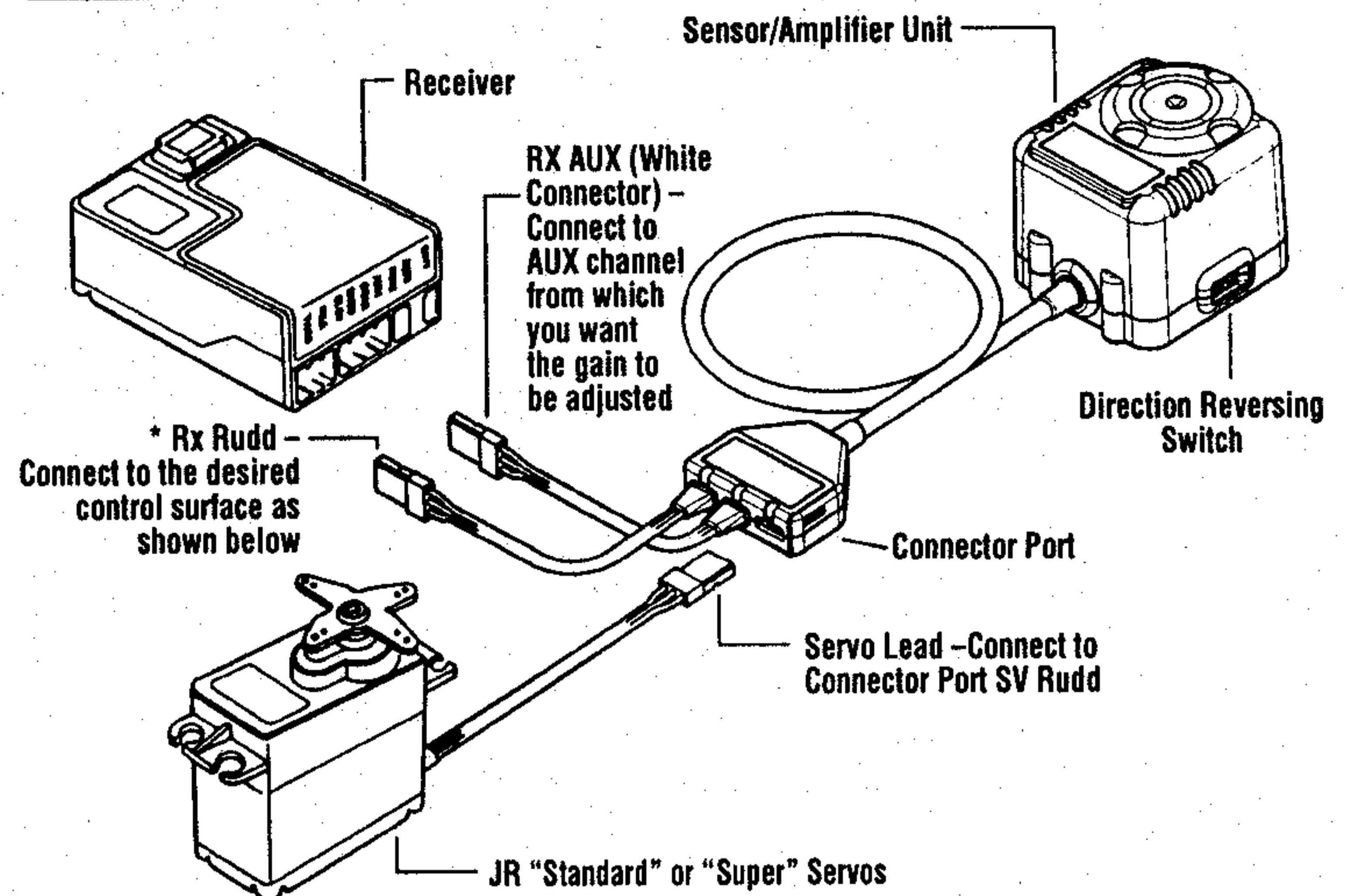

### \*Receiver Channel Connections

- Rudd - Rudder/Tail Rotor Control (airplane/helicopter)
- Aile - Aileron Control (airplane only)
- Elev - Elevator Control (airplane only)

### Servo Selection

The NEJ-900 Piezo gyro offers greatly improved response time, sensitivity and performance as compared to current mechanical type gyros. However, in order to realize these improvements, great care and consideration must be taken in the selection of the servos to be used.

In general, the quicker the transit time and the more accurate the centering tendencies of the servo, the better the gyro will perform.

If a servo with a slow transit time is used, in actuality the NEJ-900 may become too quick for the servo, resulting in a "wag" or "hunting" situation which will require the user to reduce the percentage of gain. This reduction in gain will also reduce the holding power and, therefore, the performance of the NEJ-900. The following JR servos are recommended for use with the NEJ-900:

STANDARD SERVOS	TRANSIT TIME	SUPER SERVOS	TRANSIT TIME
JRPS531 Premium Sport Servo	.21 sec/60°	JRPS4000 Ultra Linear Super Servo	.19sec/60°
JRPS4131 Ultra Precision Servo	.23 sec/60°	JRPS7100 Low Profile Super Servo	.19sec/60°
JRPS4721 Ultra Torque Servo	.22 sec/60°	JRPS2700G Ultra Speed Super Servo	.09sec/60°
JRPS4735 Ultra Speed Servo	.15 sec/60°		

## INSTALLATION AND HOOK-UP

### Gyro Sensor/Amplifier Unit

There are three important criteria that must be considered in deciding on the position you should mount the Gyro sensor.

**#1 Heat.** The Piezo sensor is sensitive to drastic temperature changes in some cases a neutral drift will occur.

When mounting the Gyro Sensing Unit, be sure it is located away from the engine and exhaust system so none of the heat will transfer to the Gyro Sensing Unit from these or any other helicopter parts that might change temperature during operation.

Also, when subjecting your helicopter to temperature differentials (e.g., going from your warm car to the cold outside), allow the gyro's temperature to stabilize for about 10 minutes before flying.

*Special Note:* Fuselages can circulate hot air throughout the internals. It is important to have adequate ventilation, both incoming and outgoing, to allow the hot air to escape during operation.

**#2 Vibration.** The Piezo gyro is 10 times more sensitive to rotational motion than a standard mechanical type gyro. Plus, it has a 10 times faster response time (the time it takes the gyro system to react to motion). Because vibration is motion, the Piezo gyro senses even minute vibrations and acts upon them (sending the servo an opposing command) 10 times faster than a standard gyro.

It is, therefore, important to reduce the vibration of your model to a minimum by making sure that everything is balanced, straight and properly adjusted.

The Gyro sensor should be mounted away from inherent high vibration areas (i.e., engines).

**#3 Location.** The Gyro Sensing Unit should be mounted as close to the center of gravity (normally the main shaft or wing C.G.) as possible while taking into account the points made in #1 and #2 above. Many helicopters provide mounting bases near the main shaft. Use them only if they are positioned away from heat-generating sources. If it is not possible to locate the sensor near the main shaft, an alternate location to consider is up front on the servo tray.



## Installing the Gyro Sensor/Amplifier

Refer to the diagrams below for proper Gyro Sensor/Amplifier positioning. This is based on the desired control function that the NEJ-900 is intended to be used.

### Helicopter Installation (Tail Rotor/Rudder)

Mount the NEJ-900 Sensor/Amplifier with the label facing upward as shown in the diagram below. Please note that the Sensor/Amplifier Unit must be mounted so the sides of the unit are parallel to the main rotor shaft.

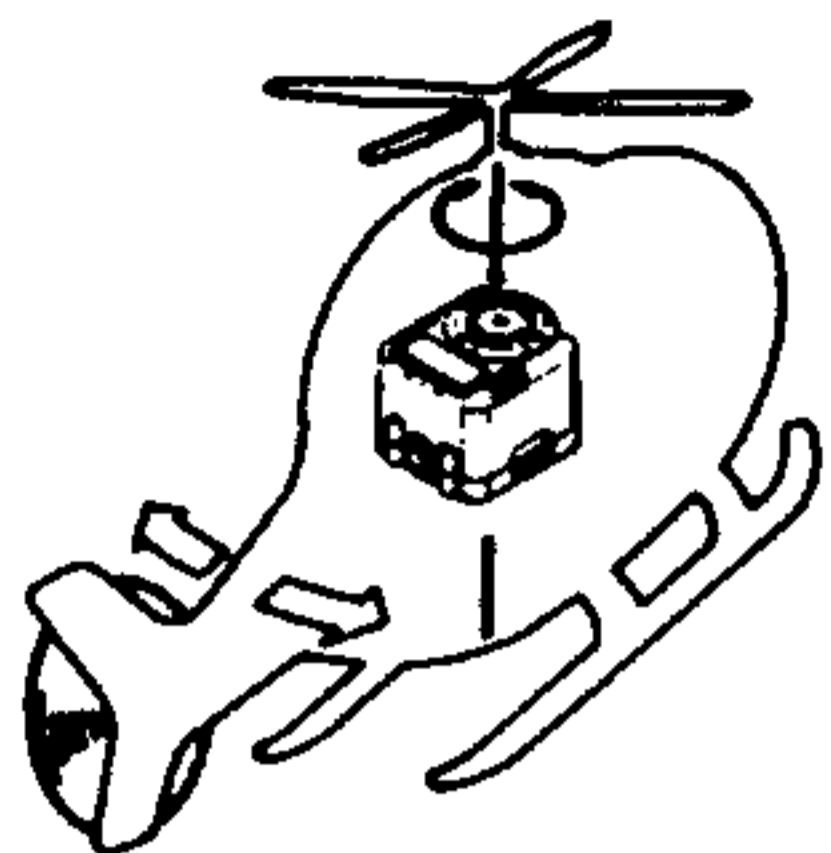

### Airplane Installation (Rudder Channel)

Mount the NEJ-900 Sensor/Amplifier with the label facing upward (or downwards) as shown in the diagram below. Please note that the Sensor/Amplifier Unit must be mounted so the sides of the unit are 90° to the center line of the fuselage.

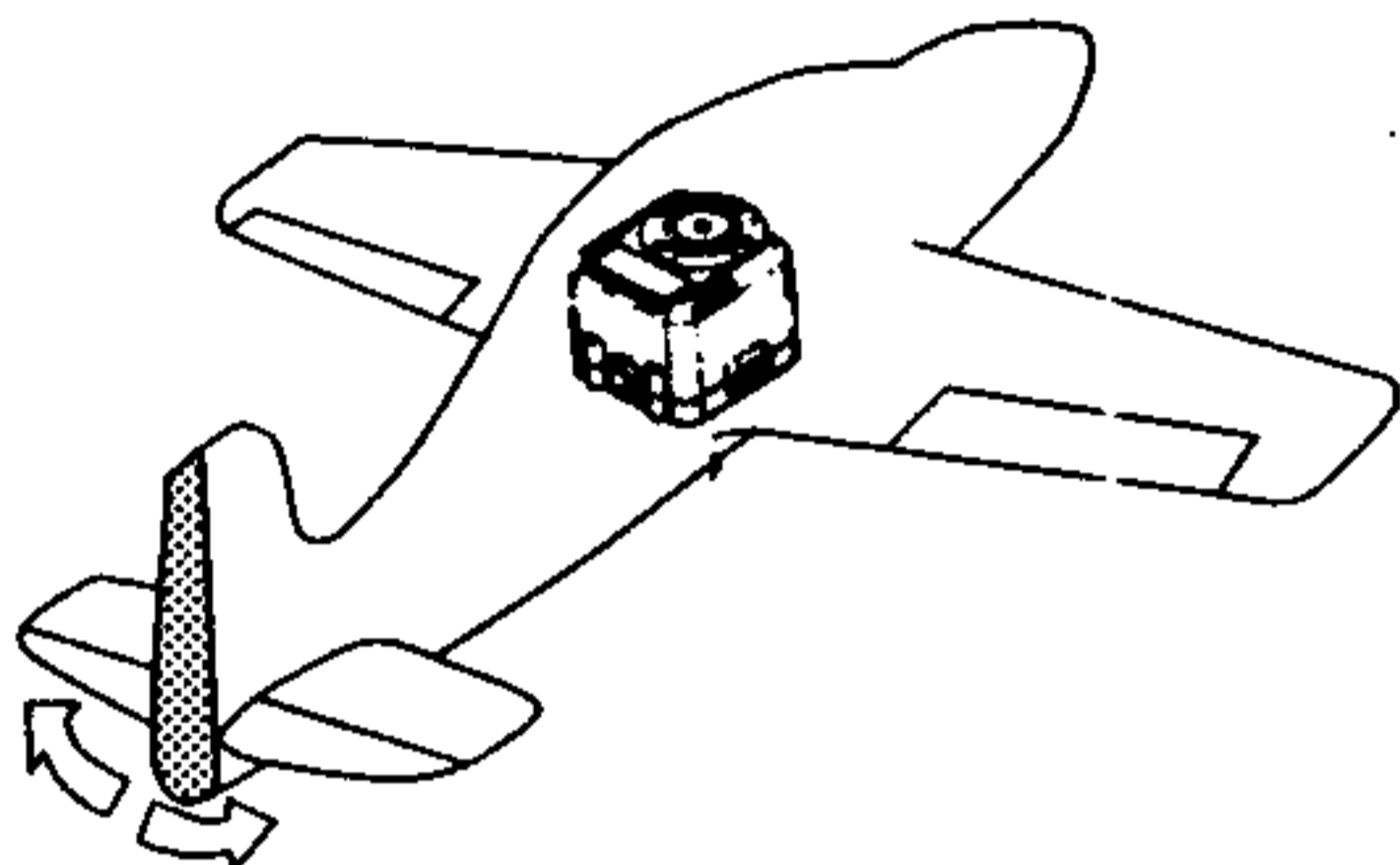

### Airplane Installation (Aileron Channel)

Mount the NEJ-900 Sensor/Amplifier so that the label faces either the front or back of the model as shown below. Be sure to attach the servo mounting tape to the side of the Sensor/Amplifier Unit opposite that of the direction reversing switch.

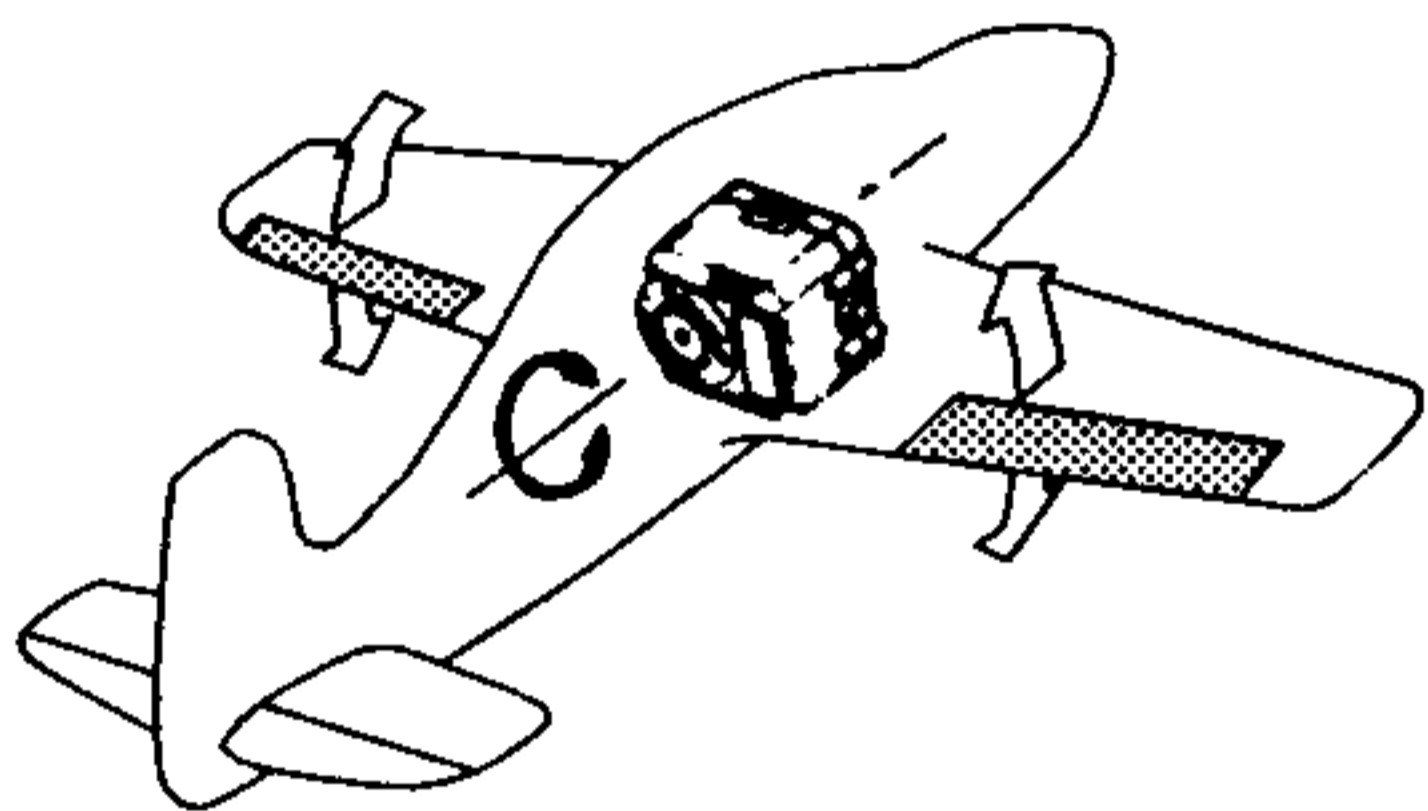

### Airplane Installation (Elevator Channel)

Mount the NEJ-900 Sensor/Amplifier so the label faces either the left or right side of the model as shown below. Be sure to attach the servo mounting tape to the side of the Sensor/Amplifier Unit opposite that of the direction reversing switch.

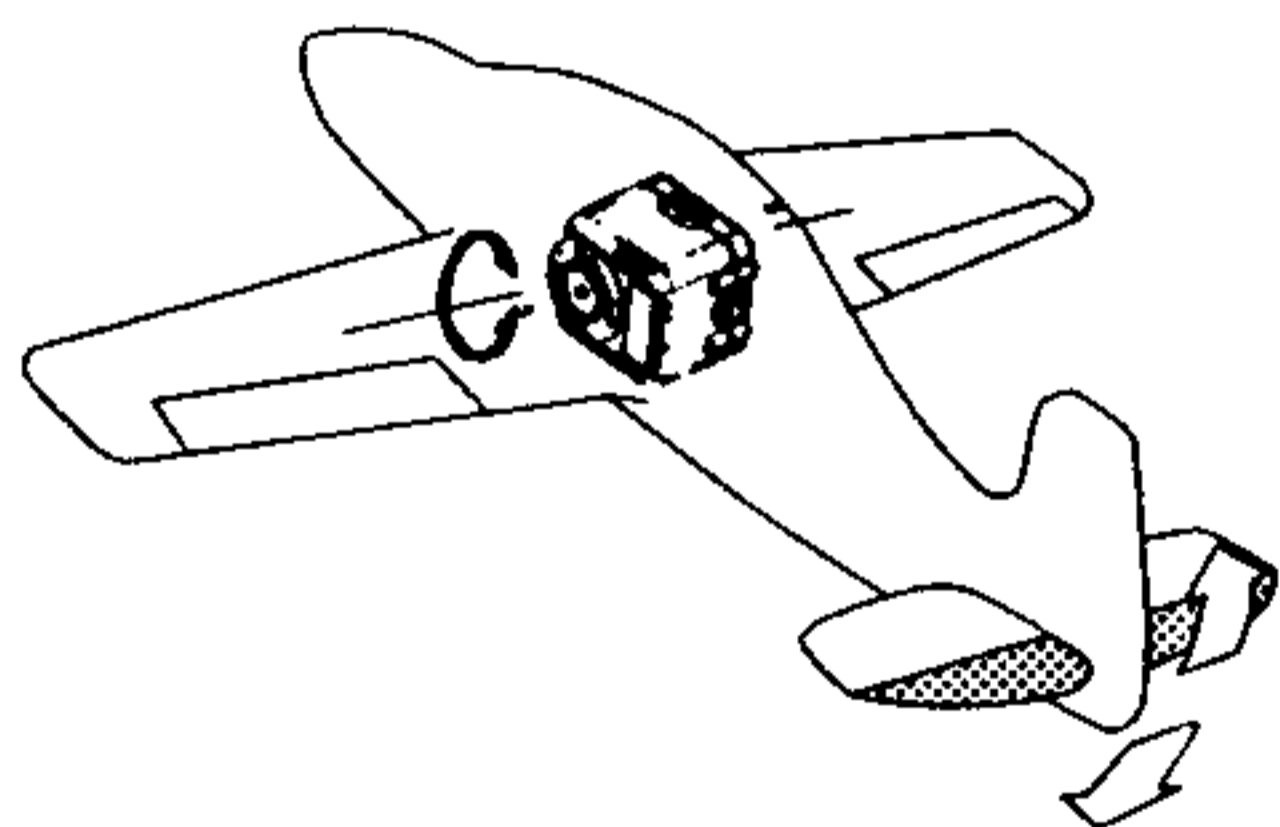

Be sure to thoroughly clean the Sensor/Amplifier mounting area and the aircraft's mounting location with rubbing alcohol prior to attachment. Use one layer of the supplied double-sided tape to secure the unit in place. It is not recommended that "thick" foam tape be used as this could reduce the effectiveness/performance of the NEJ-900 system.

**Note:** Never install/mount the amplifier unit directly to bare wood as it is possible for it to loosen during flight. Always seal the wood surface with paint, epoxy, or CA adhesive prior to mounting.

## Installing the Connector Port

The connector port can be installed in any desired position that is free from vibration. Use double-sided tape or combine the connector port with the receiver in protective foam.

## Final Connections

**Step 1:** Insert the connector port's AUX connector (white) to the AUX channel on the receiver from which you would like the gain control to be activated.

For example, if you would like the gain to be adjustable from a rotary or 2 position switch, connect the AUX connector to the appropriate AUX channel on the receiver. If you are using a PCM-10, 10S or 10SX and would like to make sure of the Code 44 gyro sensitivity adjustment feature, connect the AUX connector into AUX channel 3 of the receiver.

**Step 2:** Connect the RX Rudder connector from the connector port to the desired channel/function.

CHANNEL	FUNCTION
Rudd	Rudder/Tail Rotor (airplane & helicopter)
Aile	Aileron Control (airplane only)
Elev	Elevator Control (elevator only)

If the connector port is located away from the receiver, an optional servo extension (purchased separately) may be used.

**Step 3:** Connect the desired servo to be used into the SV Rudder jack located on the connector port. If multiple servos on the same channel are to be used (e.g., 2 aileron servos, 2 elevator servos, etc.) or the servo lead is not long enough, optional servo extension or Y-harnesses can be used.

## SET-UP AND ADJUSTMENT — HELICOPTER

The NEJ-900 Piezo gyro gives true linear feedback and response of rotation rates up to over 720 degrees per second (standard gyros are limited to approximately 250 degrees per second).

Thus, the gyro is still sensing at high rotation rates, giving appropriate feedback to the servo. This allows for more consistent pirouettes in the wind and improved 540 stall turns with aggressive stops.

Because of this high rate of rotation sensing, the adjustment values (i.e., travel adjust, dual rates, exponential, tail rotor compensation) will be very different than what you are used to.

Following is the setup and adjustment procedure that must be followed to achieve the highest level of performance from your system.

### Set-Up

**Step 1:** Unhook the tail rotor linkage from your rudder servo and swing the servo arm out of the way. Lightly grasp the tail rotor pushrod at the servo end and run the tail rotor through its entire pitch range. The tail rotor linkage should move through its entire range smoothly with very little friction and no rough spots. Work on the linkage system until this is achieved.

**Step 2:** On your transmitter, set all rudder trimmers (sub-trim, trim offset, mechanical trim, etc.) to zero. Set the throttle/pitch stick at exactly the hover position (standard hover position is 50%, switchless inverted position is 75%). Turn off or zero out both the revolution mixing up and down and the acceleration mixing.

**Step 3:** Turn on your receiver and allow the helicopter to remain totally motionless for 3 seconds. This procedure is necessary to allow the NEJ-900 time to establish and record the center or neutral positions.

**Step 4:** Remove the servo arm and replace it so that it is exactly 90 degrees to the tail rotor pushrod (see diagram). You may find that the splines in the screw output shaft are just offset enough on your servo arm so as to not allow 90 degree positioning. Rotate the servo arm to another arm and try again. Find the arm that is closest to 90 degrees and secure it in place with the provided screw.

Re-attach the pushrod to the arm approximately 8mm out. Later we will optimize this position.

**Step 5:** Be sure the rudder servo is moving in the proper direction. A right servo command should move the nose to the right (if you're unsure, seek help from someone more experienced). Reverse the servo direction in the transmitter if necessary.

**Step 6:** Give a right rudder command and note the direction the rudder servo moves (clockwise or counterclockwise). Now pick up the helicopter and quickly move the nose to the left. The servo should move in the same direction. If it moves in the opposite direction, switch the small reverse switch located on the gyro sensor/amplifier in the opposite direction.

**Step 7:** To verify that the NEJ-900 is compensating in the correct direction, please refer to the diagram at right for clarification:

With a quick motion, rotate the nose of the helicopter to the left while viewing the servo arm/tail rotor blades. If correct, the leading edge (front) of the tail rotor blades should pitch to the left as shown. Reverse the direction of the gyro compensation if necessary using the Direction Reversing Switch located on the Sensor/Amplifier Unit.

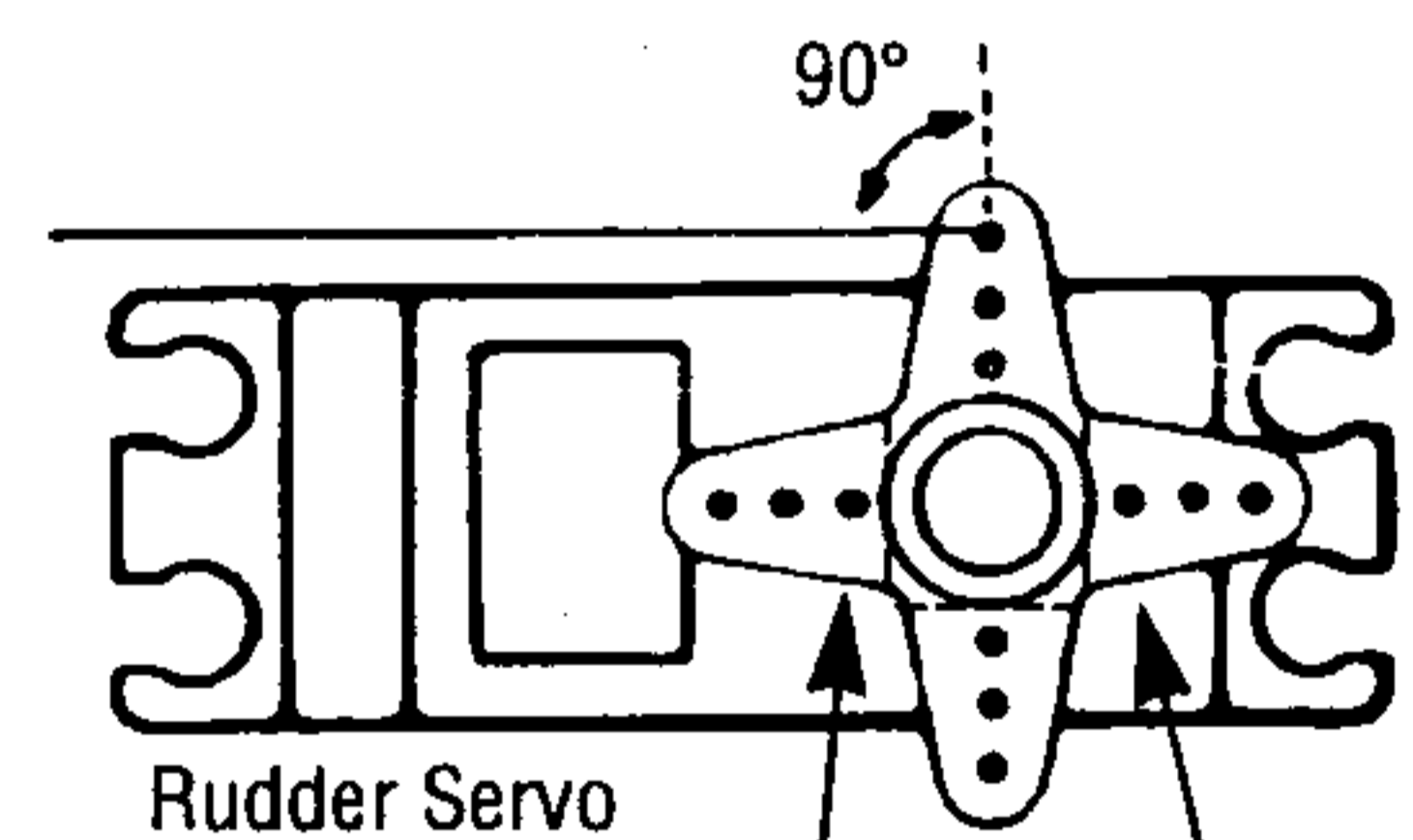

Remove unused servo horn arms to prevent obstruction.

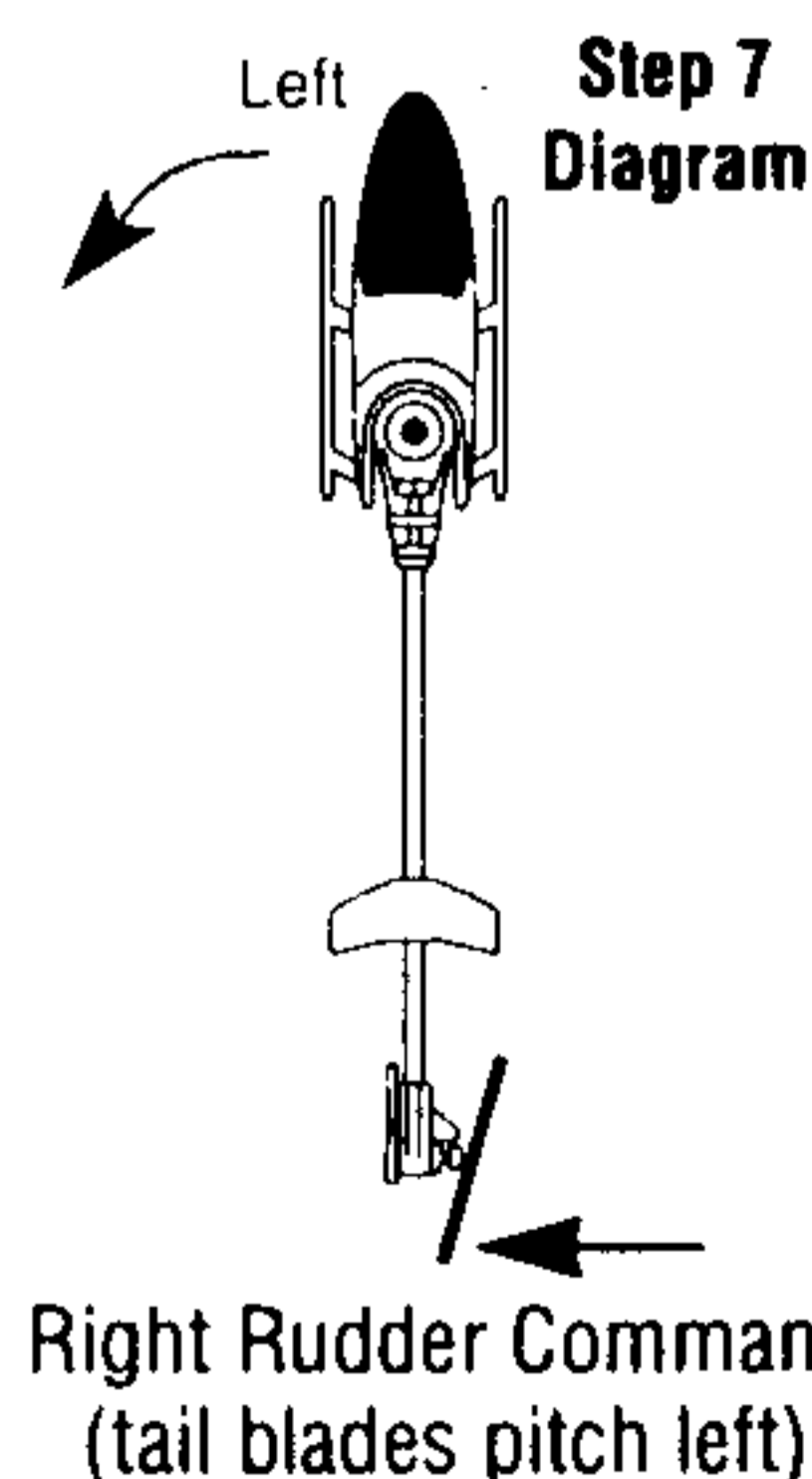

## Overdriving the Tail Rotor

As illustrated above, the transmitter gives a command to the servo to find a specific position (e.g., full right rudder). The gyro senses the right rotation and gives the opposite command (left) to the servo. The final servo position (and hence the rotation rate) is based on the transmitter's command versus the gyro's gain setting versus the rotation rate.

In order to get really rapid rotation rates with some helicopters, it may be necessary to use a travel adjustment that on the ground (no rotational feedback from the gyro) actually exceeds the mechanical limitations of the tail rotor mechanism. In flight, the Piezo gyro will reduce the travel so binding will not occur. But be very careful on the ground to ensure that you don't give hard over rudder commands.



## Transmitter Adjustments

### Travel Adjust

Set the rudder travel adjustment to maximum right and left. If you are using a JR PCM-10S/10SX, set this adjustment to 150% left and 150% right. **Note:** This may overdrive the tail rotor mechanism on the ground. However, in flight, the gyro will reduce the throw, preventing binding at the extremes. You can test this by physically spinning the helicopter as described previously.

### Dual Rates

The recommended starting points for dual rates are:

Maneuver	Dual Rate	Flight Mode
Hover	60%	Normal
540 Stall Turn	90%	Flight Mode 1
Standard Aerobatics	60%	Flight Mode 2

After some experience and flight time is gained, these values can be adjusted to suit your preference. We recommend adjusting the dual rate values to obtain the desired maximum rotational rate during a maneuver.

### Example:

If 90% dual rate yields too high of a rotation rate in the 540 stall turn when the rudder stick is fully displaced, reduce the dual rate value until the desired rotation rate is achieved.

### Exponential

Because a very large servo stroke is utilized (150% L, 150% R), the control sensitivity around neutral is very high. Exponential is recommended to reduce this over-sensitivity around neutral. Following are the recommended expo settings:

Maneuver	Exponential Value	Flight Mode
Hover	30%	Normal
540 Stall Turns	30%	Flight Mode 1
Std Aerobatics	40%	Flight Mode 2

After some experience and flight time is gained, these values can be changed to suit your preference.

We recommend using exponential to adjust the control sensitivity from neutral to approximately 1/3 stick position.

### Revo Mixing

The NEJ-900 actually increases the total servo stroke by approximately 35%. Compared with previous gyro systems, the Piezo gyro will require that you reduce the revo mixing, stunt trim, and +/-P values by approximately 35%.

Following are some basic starting values to work with.

**Note:** Because of the variables involved with each different helicopter (i.e., engines, fuel, blades, exhaust systems, aerodynamics, gear ratios, etc.), the optimum can only be achieved with careful tuning and adjustment to your particular helicopter.

### PCM-10S/10SX REVO MIXING

### OTHER JR SYSTEMS

Normal	Up 20%	Down 15%	Normal	Up 20%	Down 15%
Flight Mode 1	+P5	-P5	Flight Mode 1	Up 5%	Down 5%
Flight Mode 2	+P5	-P5	Flight Mode 2	Up 5%	Down 5%

### Stunt Trim

Test fly and adjust until the tail follows exactly behind the body in fast forward flight, full throttle/pitch.

## SET UP AND ADJUSTMENT — AIRPLANE

The NEJ-900 Piezo gyro gives true linear feedback and response at a rate of up to 720 degrees per second. This allow the NEJ-900 to continue sensing motion even at high rotation rates, giving the appropriate feedback to the servo.

Because of this high rate of rotation sensing, the adjustment values of the travel adjust, dual rate, and exponential will need to be altered from their original values to achieve full performance from the NEJ-900.

The following is the set-up and adjustment procedure that should be followed to achieve the highest level of performance from your system.

### Set-Up

**Step 1:** Unhook the control linkage pushrod from the appropriate servo arm and rotate the servo arm out of the way. Lightly grasp the pushrod at the servo arm end and move the control surface through its entire travel range. The pushrod/control surface should be able to move throughout its entire travel range smoothly, with the least amount of friction and without rough or "binding" spots. Make adjustments to the pushrod/control surface as necessary until a smooth operating system is achieved.

**Step 2:** Next, on your transmitter, set all the trim levers, knobs, etc., to their zero position for the specific channel to be used (rudder, aileron, elevator, etc.).

**Step 3:** Turn on your transmitter, then your receiver, and allow the model to remain totally motionless for at least 3 seconds. This will allow the NEJ-900's circuitry to determine the exact center position from which all inputs will be based.

**Step 4:** Remove the servo arm from the servo and now re-position it so that it will be exactly 90 degrees to the control surface pushrod (see diagram). In doing so, you may find that the splines in the servo output

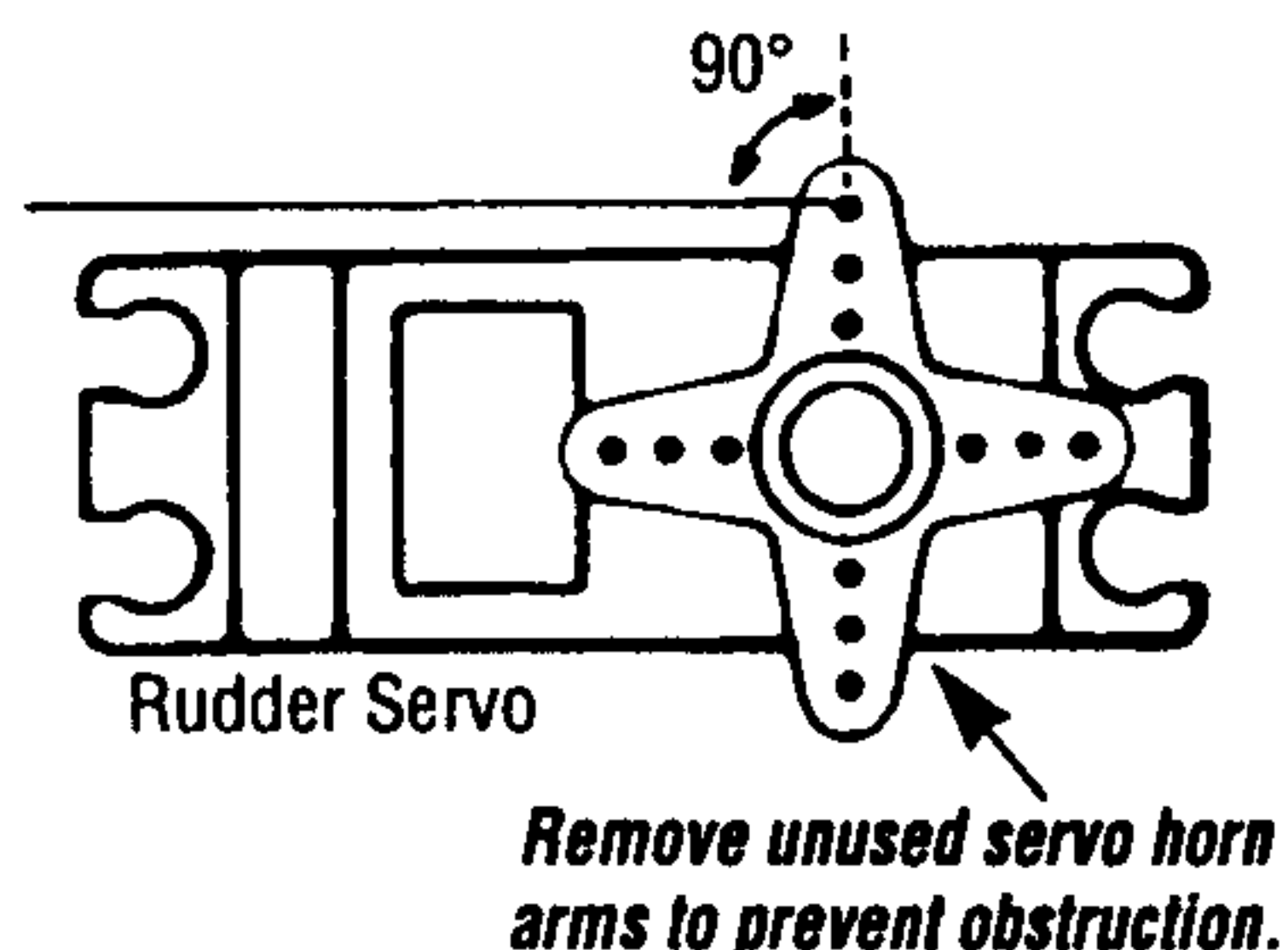

shaft are aligned in such a way that prevents 90 degree positioning of the servo arm. To correct this problem, rotate the servo arm 180 degrees from its original position and re-install. Once correct alignment has been achieved, secure the servo arm to the servo using the original mounting screw. Next, re-attach the control surface pushrod to the servo arm in its original hole location. Later we will determine the optimum servo arm hole.

**Step 5:** Check the control surface to make sure the servo moves the surface in the appropriate direction as compared to the transmitter's control stick. Reverse the servo direction if necessary.

**Step 6:** It is now time to verify that the NEJ-900 is functioning, and that it is compensating in the correct direction.

To verify that the NEJ-900 is functioning, simply rotate or turn the model while watching the control surface or servo that it is to be controlling. If any movement of the servo arm or control surface is detected, the NEJ-900 is functioning.

To determine the correct compensation direction, it will be necessary to again move the model while watching the servo arm or control surface, noting the correct compensation direction as shown below:

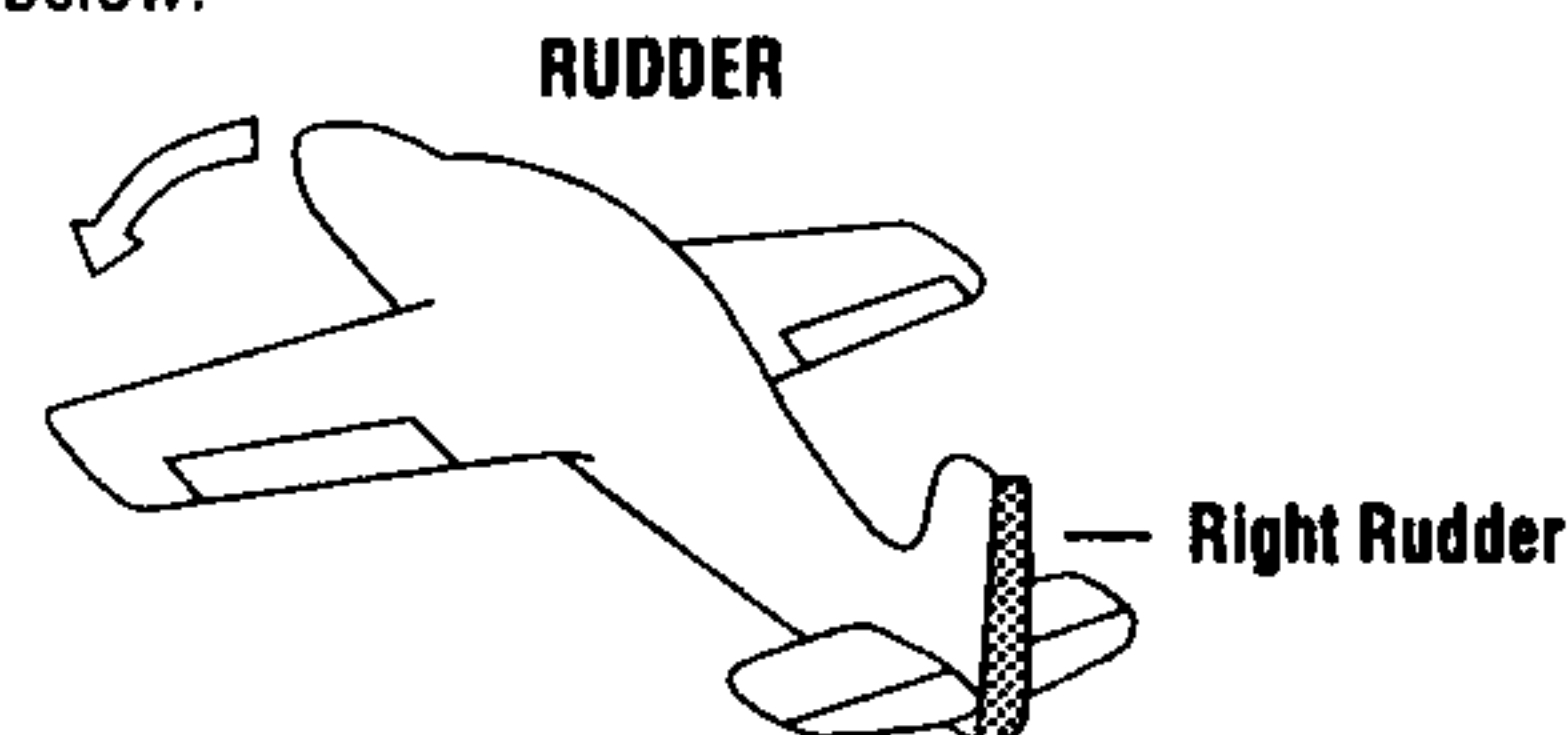

With a quick motion, move the nose of the aircraft to the left, the rudder should deflect to the right as shown above.

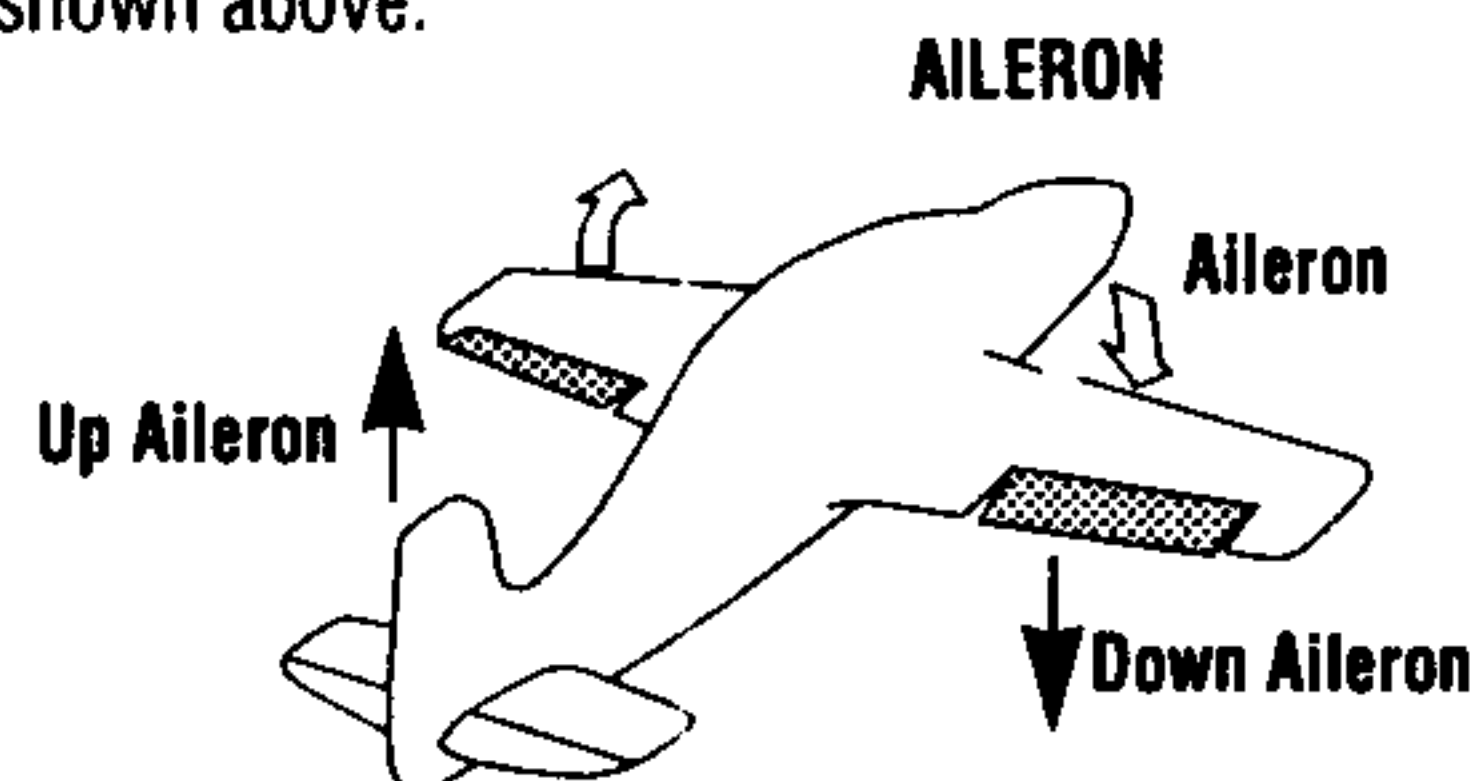

With a quick motion, rotate the fuselage of the model to the right, the ailerons should give a "left control" input as shown above.

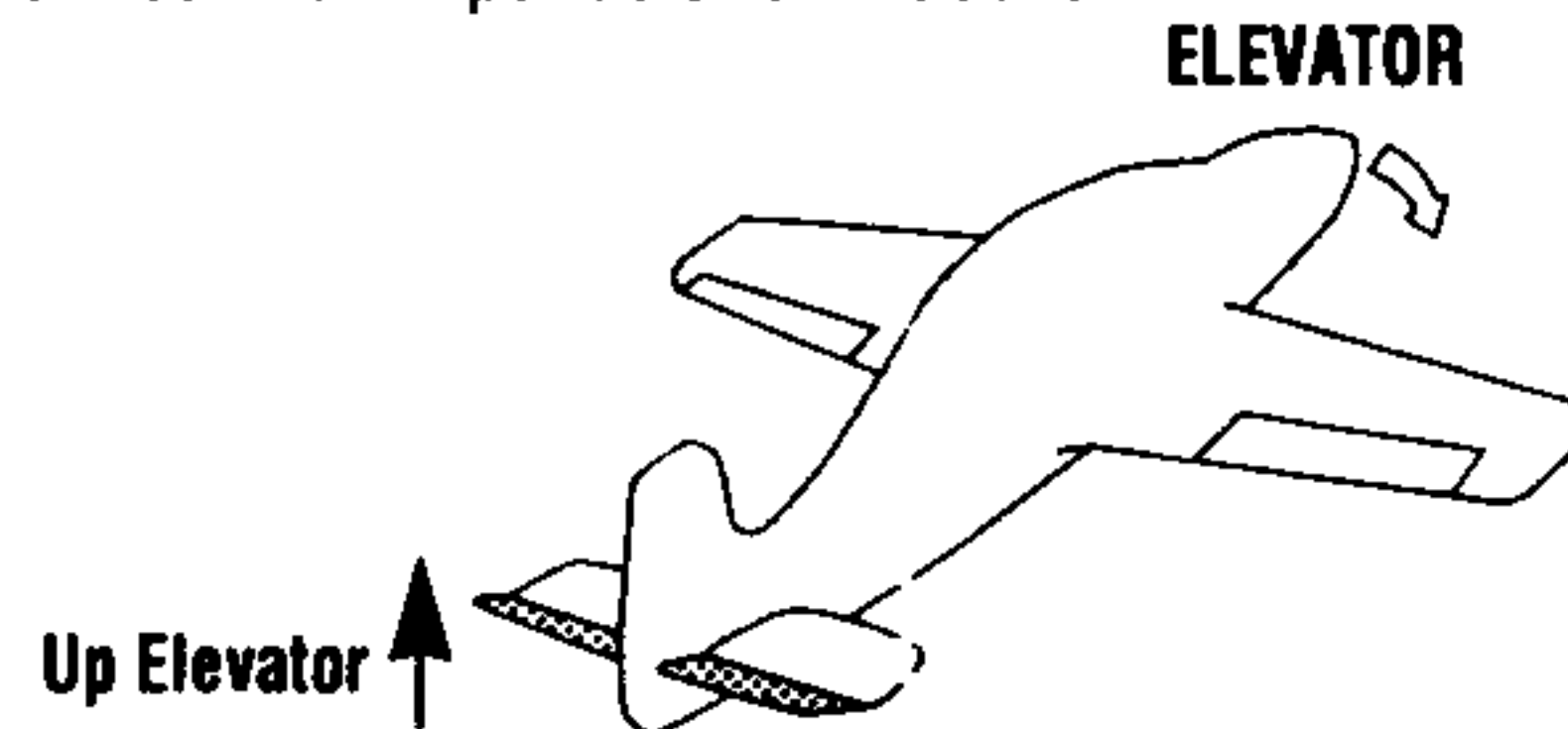

With a quick motion, rotate the nose of the fuselage down as shown above. The elevator should give an "up" control input as shown above.

To reverse the direction of the gyro compensation, simply move the reversing switch located on the gyro sensor/amplifier to the opposite position.

## Transmitter Adjustments

### Control Surface/Travel Adjustment

To achieve the highest level of performance from the NEJ-900 in your airplane, it is necessary to re-set the servo travel adjustment value and also the control surface pushrod location on the servo arm as follows:

### Travel Adjustment

In general, to achieve the highest level of performance from the NEJ-900, the larger the travel volume is adjusted, the better the NEJ-900 will perform.

In most JR radio systems, the factory pre-set for the travel adjustment function is 100% in each direction, but has a maximum value of 150%. To achieve the greatest level of performance, it is suggested that the travel adjustment be increased to its maximum possible setting. In doing so, it may be necessary to re-position the control surface pushrod on the servo arm or control horn to eliminate any "binding" or "over travel" that may occur with the increase in travel adjustment. To reduce control surface travel, simply move the pushrod inward on the servo arm one hole at a time or out on the control horn until the proper control surface travel is achieved. It is very important that this procedure be followed carefully so as not to cause the control surface to over travel during use.

### Dual Rates

Once the proper control surface travel has been achieved, it may also be necessary to re-adjust the dual rate values to achieve the desired deflection.

### Exponential

Once the travel adjustment value for the control surface has been increased, the control surface sensitivity/input around neutral will also become more sensitive. Exponential is recommended to reduce this over-sensitivity around the neutral position to de-sensitize the feel of the control surface.

A good starting point for an exponential value should be in the area of 20%-40%.

After some experience and flight time is gained, these values can be changed to suit your preference.

## Remote Gain Control Set-Up: Helicopter Only

### Remote Gain Control Set-Up with the JR PCM-10/10S/10SX (Helicopter)

The Remote Gain Controller allows adjustments to be made from the transmitter. When using the PCM-10SX, plug the Remote Gain Controller's AUX connector into the receiver's AUX 3 jack. This will allow gain control adjustments to be made in Code 44 of your transmitter. (Also see the PCM-10/10SX instruction manual, Code 44).



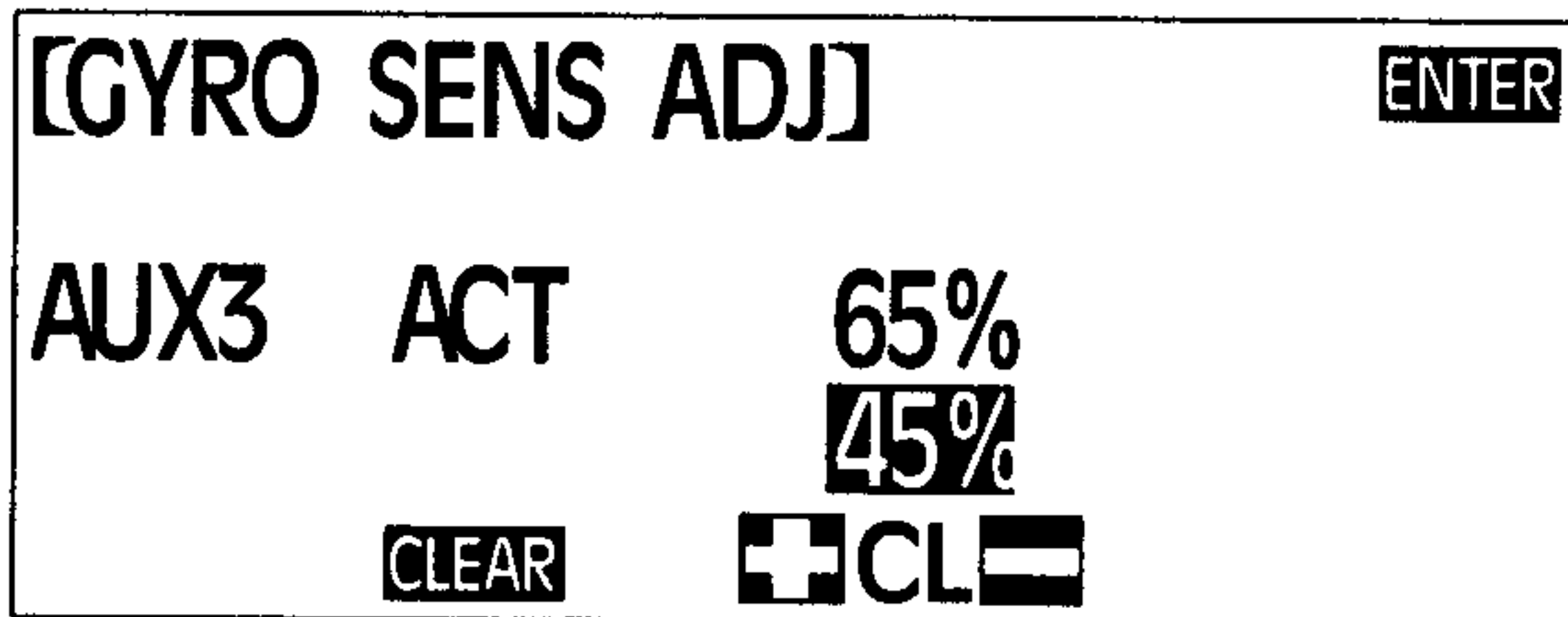

**Code 44**

Enter Code 44 in your transmitter. Press the ACT on the screen to activate the gyro sensing adjustment. Notice that, by flipping the AUX 3 switch on the upper right of the TX, the bold portion changes from top to bottom. The bolded value can be changed by pressing the + or - key. For hover (normally the top value), set a starting value of 65%. For forward flight, set a value of 45%. See the screen example above.

Please refer to the PCM-10SX instructions for further information.  
For flight adjustment, please refer to Section 4.3 of these instructions.

**Remote Gain Control Set-Up: Helicopter Only**

**JR XP8103: Helicopter Mode**

The JR XP8103 offers two different types of gyro sensitivity adjustments, manual or automatic. This feature gives the user the choice of selecting gyro sensitivity manually through the Rudder D/R Switch or automatically through the Flight Mode Switch.

When using this feature, connect the remote gain controller AUX connector (white) into the AUX 2 channel of the receiver. Next, select either the manual or automatic gyro sensitivity feature and adjust the gyro rate values as shown below:

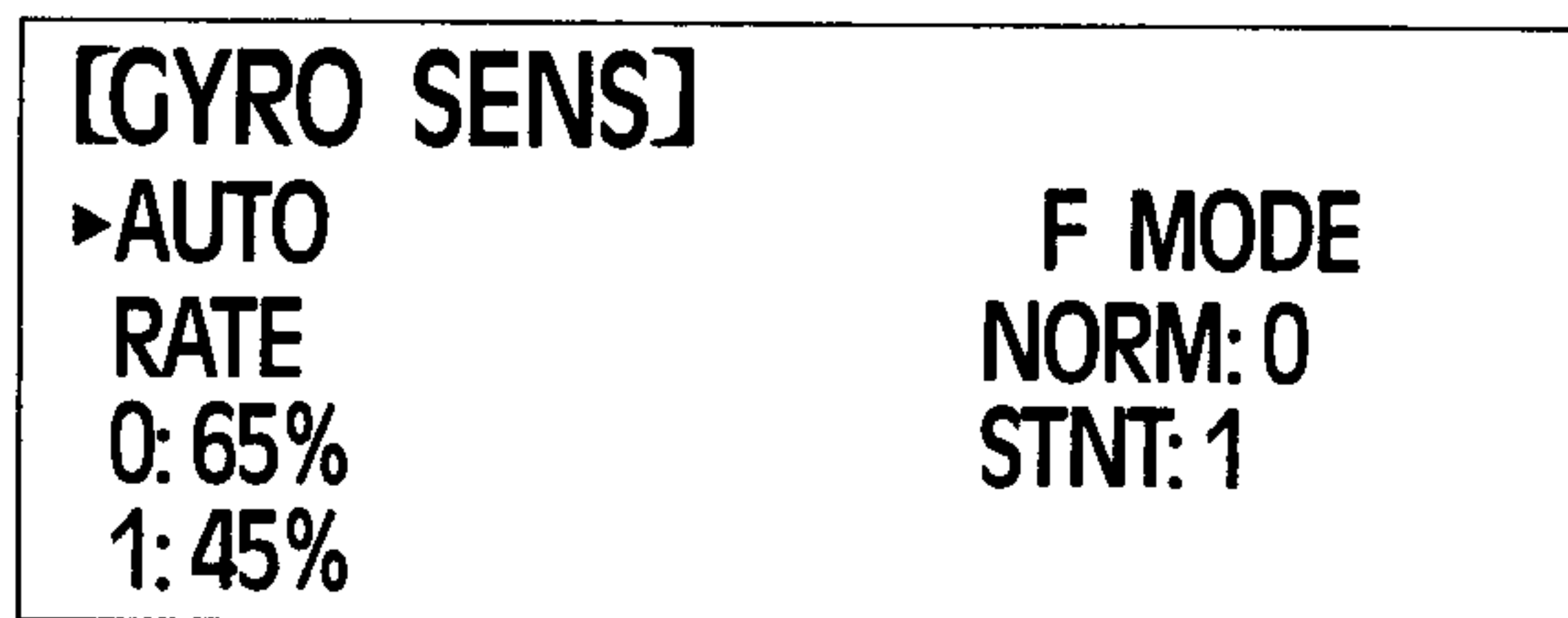

Please refer to the XP8103 instruction manual for further information.  
For flight adjustments, please refer to Section 4.3 of these instructions.

**Remote Gain Control Set-Up: Helicopter and Airplane**

**Remote Gain Control Set-up with Other Radios**

The NEJ-900's remote gain adjustment feature also works with other systems that have AUX channels.

In the case of a proportional knob, plug the white AUX connector from the NEJ-900's connector port into the appropriate receiver jack (channel).

Proportional gain can then be achieved by rotating the knob to the desired position.

If a two position switch channel is available, the gain sensitivity can be adjusted in each position using the travel adjustment function.

The following is a chart of all JR radio systems denoting the switch type and appropriate channel # to be used.

Radio: Helicopter	Switch Type	Type	Channel #
XP642	(must use combined function feature)	Gear	5
XF622	(must use combined function feature)	Gear	5
XP783	2 Position	Aux 2	7
XP8103	Refer to Remote Gain Control Set-Up (Helicopter Only)		
PCM10SX	Refer to Remote Gain Control Set-Up with JR PCM-10/10S/10SX		

Radio: Airplane	Switch Type	Type	Channel #
XP642	2 Position	Aux 1	6
XF622	2 Position	Aux 1	6
XP783	Rotary/2 Position	Aux 2, Aux 2	7
XP8103	Rotary/2 Position	Aux 2, Aux 3, Aux 2	7,8
PCM10SX	Rotary/2 Position	Aux 4, Aux 5, Aux 2	7,9,10

When using a switched channel for gain control, the gain adjustment is achieved by adjusting the endpoints of that switched channel. See below:

Switch position #1: Gain is adjustable from 50% to 100% using the travel volume.  
100% Travel volume = 100% gain  
0% Travel volume = 50% gain

Switch position #2: Gain is adjustable from 0% to 50% using the travel volume.  
100% Travel volume = 0% gain  
0% Travel volume = 50% gain

**Note:** In switch position #1, increasing the travel volume value increases the gain. In switch position #2, increasing the travel volume value decreases the gain.

**Note:** Depending on the position of the AUX channel's reversing switch, the switch position #1 and #2 may work in reverse. It is recommended that the initial gyro gain rates be set at 45% (low) and 65% (high) for initial test flights.

**Gain Value Adjustments**

**Helicopter**

On initial test flights it will be necessary to adjust the mechanical control linkage/tail rotor blade pitch so that the helicopter will have no tendency to rotate while in the hover position. Minor "fine tuning" adjustments can be made with the rudder trim lever. Once this has been achieved, increase the hover gain (pre-set at 65%) until the helicopter starts to oscillate (hunt). Back down the value just below the hunting point. The value should be between 65 and 95 percent. If so, proceed to the next step. If not, do the following:

Hunting occurs at less than 65% gain in hover—move the rudder pushrod connection at the servo inward one hole on the servo arm.

No hunting occurs even at 100% gain in hover—move the rudder pushrod connection at the servo outward one hole on the servo arm.

Next, fly the helicopter in fast forward flight and increase the low gyro gain value until oscillation (hunting) occurs. Reduce the value slightly, just below the point of hunting. Try a few rolls and see if hunting occurs. Reduce the gain if necessary.

Now go back and fine tune your revo mixing, stunt trim, +P, -P, etc., using your standard method or the method given in your specific radio's instruction manual.

**Airplane**

On initial test flights, it will be necessary to adjust the control surface/pushrod mechanical linkage so that the model flies straight and level without any stick control inputs. Minor "fine tuning" adjustments can be made with the radio trim levers. For the first test flights it is recommended that the gyro gain be set to a low setting of (0 to 20%) and a high setting of (65%). For the first takeoff be sure the gyro gain switch used is set to the low gain position. This will ensure the gain adjustment selected will not be too high, causing the gyro to oscillate (hunt), causing erratic control on that particular control surface and/or override the stick input causing insufficient control authority to fly the model.

Once sufficient altitude has been achieved, the gain may then be switched to the high gain position (65%) for testing at a safe altitude. Increase/decrease the gyro gain as necessary until the desired compensation rate and control feel has been achieved. For maximum gyro compensation, gradually increase the gain until the control surface begins to oscillate while the model is flying at full speed. Then slightly decrease the gain from that setting. The maximum gain value will vary depending on the particular models speed and control surface authority. A low gain setting can be used for full speed flight and a higher gain for lower speed flight.

**WARRANTY COVERAGE**

Your new equipment is warranted to the original purchaser against manufacturer defects in material and workmanship for 1 year from the date of purchase. During this period, Horizon Service Center will repair or replace, at our discretion, any component that is found to be factory defective at no cost to the purchaser. This warranty is limited to the original purchaser of the unit and is not transferable.

This warranty does not apply to any unit which has been improperly installed, mishandled, abused, or damaged in a crash, or to any unit which has been repaired or altered by any unauthorized agencies. Under no circumstances will the buyer be entitled to consequential or incidental damages. This limited warranty gives you specific legal rights; you also have other rights which may vary from state to state. As with all fine electronic equipment, do not subject your unit to extreme temperatures, humidity or moisture. Do not leave it in direct sunlight for long periods of time.

**REPAIR SERVICE INSTRUCTIONS**

In the event that your equipment needs service, please follow the instructions listed below:

1. Return your system components only. Do not return your system installed in a model helicopter, plane, etc.

2. Use the original carton/packaging (molded foam container), or equivalent, to ship your unit. Do not use the carton itself as a shipping carton; you should package the equipment carton within a sturdy shipping container using additional packing material to safeguard against damage during transit. Include complete name and address information inside the carton, as well as clearly writing it on the outer label/return address area. Ship your equipment fully insured and prepaid. Horizon Service Center is not responsible for any damages incurred during shipping.

3. Include detailed information explaining your operation of the equipment and problem(s) encountered. Provide an itemized list of equipment enclosed and identify any particular area/function which may better assist our technicians in addressing your concerns. Date your correspondence, and include your name, mailing address, and a phone number where you can be reached during the business day.

4. **Warranty Repairs.** To receive warranty service you must include a legible photocopy of your original dated sales receipt to verify your proof-of-purchase date. Providing that warranty conditions have been met, your radio will be repaired without charge.

5. **Normal Non-Warranty Repairs.** Should your repair cost exceed 50% of the retail purchase cost, you will be provided with an estimate advising you of your options.

Within your letter, advise us of the payment method you prefer to use. Horizon Service Center accepts VISA or MasterCard, or we can return the equipment C.O.D. cash-only. If you prefer to use a credit card, include your card number and expiration date.

Mail your system to:  
**Horizon Service Center**  
4105 Fieldstone Road  
Champaign, Illinois 61821  
(217) 355-9511