

Before commencing assembly, please read these instructions thoroughly.

# Knight 50

Plastic Version

INSTRUCTION MANUAL

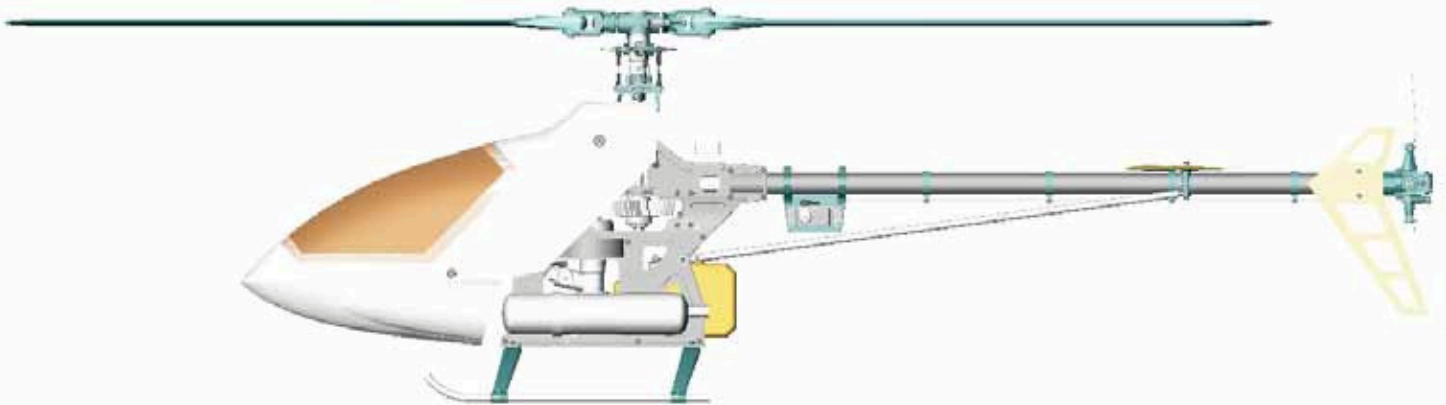

## ⚠ 注意事项

这个遥控模型并不是玩具

- 这个机器包含一个高速旋转的旋翼，并会造成危险。你需要为此模型的组装、安全（飞行地点、频率）检查及正确调校负责。
- 请在儿童接触不到的地方组装此模型。
- 运作前后都必需做足安全措施。在每次飞行后，请检查螺丝和螺母有否松脱，及零件有否磨损。为使本模型能安全运作，请即时更换、维修或调校损坏的零件。
- 请只用本公司所制造的零件作更换。使用其它公司零件或会造成意外或模型运作不良，本公司并不会对此所造成的意外或撞毁承担任何责任。
- 即使在完成安装后，请继续保留本说明书作参考。

总长度: 1270 毫米  
传动率: 8.7:1:5  
起飞重量: 3.55 公斤  
旋翼直径: 1360 毫米

## ⚠ SAFETY PRECAUTIONS

This radio control model is not a toy.

- The rotor on this model rotates with high speed and would possibly be dangerous. You are responsible for the safety operation check, assembly and adjustment of this model.
- Assemble this model only in places out of the reach of children.
- After every flights, check screws, nuts and parts for wear and looseness. For safety, damaged parts should be replaced or repaired immediately.
- For replacement, use only parts supplied by Compass Model. Parts not made by Compass Model could cause malfunctions or crashes of the model. Compass Model do not take any responsibility for any damage so caused.
- Keep this instruction manual as reference even after assembly.

Total length: 1270mm  
Transmission rate: 8.7:1:5  
Take-off weight: 3.55kg  
Rotating diameter: 1360mm

本手册内容可有变更，无需通知。

@2004 珠海鲲鹏模型制造有限公司 版权所有 禁止复制

SPECIFICATIONS ARE SUBJECT TO CHANGE WITHOUT NOTICE.

©2004 BY ZHU HAI COMPASS MODEL MANUFACTURE LTD. ALL RIGHTS RESERVED.

未曾包括的其他必需品

NECESSARY ITEMS NOT INCLUDED IN THIS PACKAGE

以下各项并不包括在本产品内,为了正常使用,请自行购买。

In order to operate this model, you need to purchase the following items which are not included in the package.

油动直升机专用遥控设备及干电池

Radio for engine-powered R/C helis, and dry batteries.

●请使用油动直升机模型专用遥控器, 伺服器5个, 陀螺仪一个。

●使用方法请参照遥控器说明书。

●This model requires a EMS System radio for Engine-powered R/C heli with 5 servos and 1 gyro.

●For more information of the radio, please refer to the radio sets manual.

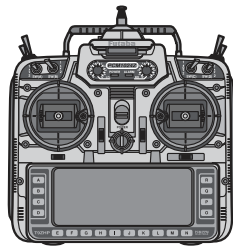

Transmitter 发射机

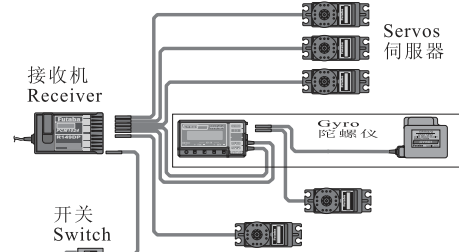

接收机 Receiver  
开关 Switch  
干电池 Ni-Cd Battery

**注意 Caution** 使用非油动直升机模型专用遥控设备可能造成重大事故。  
USE ONLY RADIO FOR ENGINE-POWERED HELI MODEL (ANY OTHER RADIO IS PROHIBITED!)

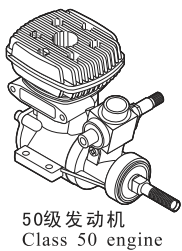

50级发动机 Class 50 engine

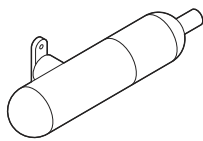

50级排气管 Muffer for 50 class

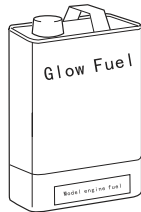

Glow Fuel 遥控模型专用燃料

1. Use only GLOW fuel for model engines, \*Do not use gasoline or kerosine. \*GLOW fuel is highly flammable and explosive, always use with care!
2. Always keep the fuel and empty fuel cans away from children.
3. Never refuel before the engine has cooled down.
4. Be careful not to drink or allow the fuel in contact with eyes.

1. 只可以使用遥控模型专用燃料。 \*不可以使用煤油或汽油。 \*此燃料是高挥发性,易燃,易爆物品。使用时务必注意安全。
2. 注意保持燃料及其容器远离儿童。
3. 一定要在发动机冷却后才可加油。
4. 该燃料不可饮用,注意不要使其接触眼睛。

Main Rotor Blades 主旋翼大桨

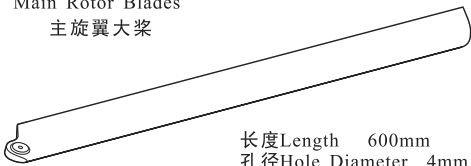

长度Length 600mm  
孔径Hole Diameter 4mm  
厚度Thickness 12mm

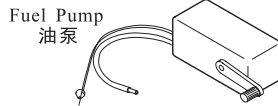

Fuel Pump 油泵



Starter Shaft 启动头

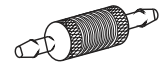

Fuel Filter 滤油器

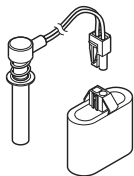

Plug Heater 加热器



Loctite Loctite 胶水



Grease 润滑油

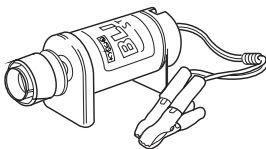

Engine Starter 起动机

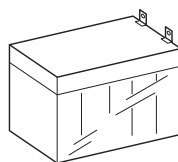

Battery for Engine Starter 蓄电池



Instant Glue 厌氧胶水

装配工具 Tools necessary for assembly

✧ 使用工具时注意安全! Handle the Tools Carefully!

六角扳手 (1.5mm, 2mm, 2.5mm, 3mm)  
Hexagon wrench (1.5mm, 2mm, 2.5mm, 3mm)



Cutter Knife 裁纸刀

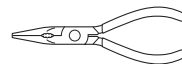

Needle Nose Pliers 尖嘴钳









Screw Driver 螺丝刀

## Index of Manual

Step 1. Landing Gear	-----	Page 4
Step 2. Paddles	-----	Page 5
Step 3. Front Servo Mount	-----	Page 6
Step 4. Install the Engine	-----	Page 7
Step 5. Tail	-----	Page 8
Step 6. Fins and Boom Supporters	-----	Page 9
Step 7. Servos	-----	Page10
Step 8. Wire Up	-----	Page11
Step 9. Radious Stay Arm	-----	Page11
Step 10. Radio Setting Data	-----	Page12
Step 11. Set Up	-----	Page 13~16
Step 12. Canopy Mount	-----	Page 17
Step 13 Canopy & Check Turning Direction	-----	Page 18
About the Decal	-----	Page 19

# Step 1. Landing Gear

						
M3x5 set screw x 4	M3x20 Socket head Bolt x 4	M3 Nylon Nut x 4	3mm Washer x 4			

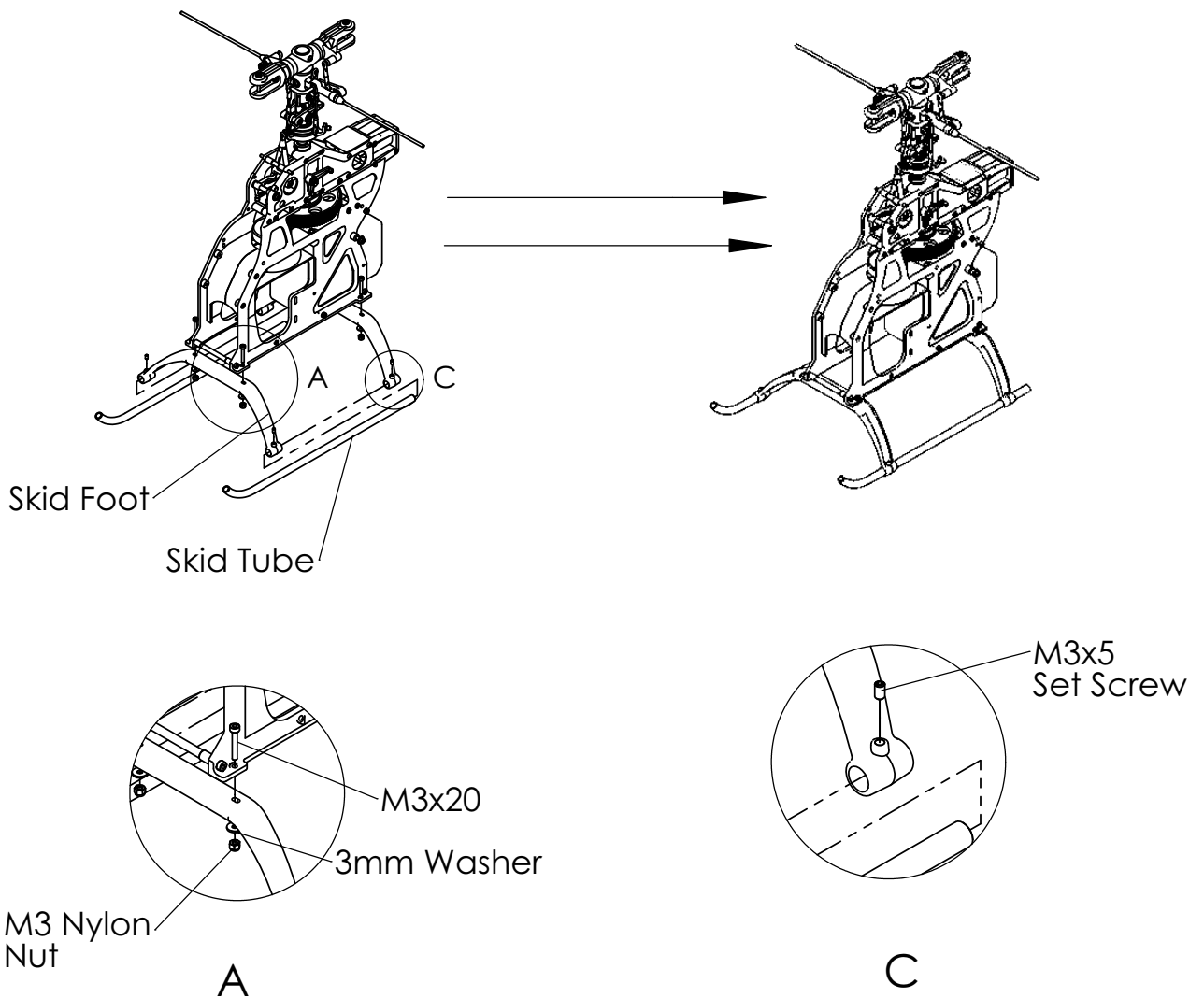

- Use M3x20 Socket Head Bolts, M3 Nylon Nuts and 4mm Washer to fix the plastic skid foot on the body. refer to detail view A.
- Insert the two alumine Skid Tube into the hole of the Skid Foot.
- Use M3x5 set screws to tight the Skid Tube on the Skid Foot. refer to detail view C.

## Step 2. Paddles

  
 M3x3 Set  
 Screw x 4

  
 M3x10 Set  
 Screw x 2

  
 M4x3 Set  
 Screw x 2

a): Screw the two **Paddles** in opposite direction onto the **Flybar** until the **Flybar** can be seen from the small hole on the **Paddle**.

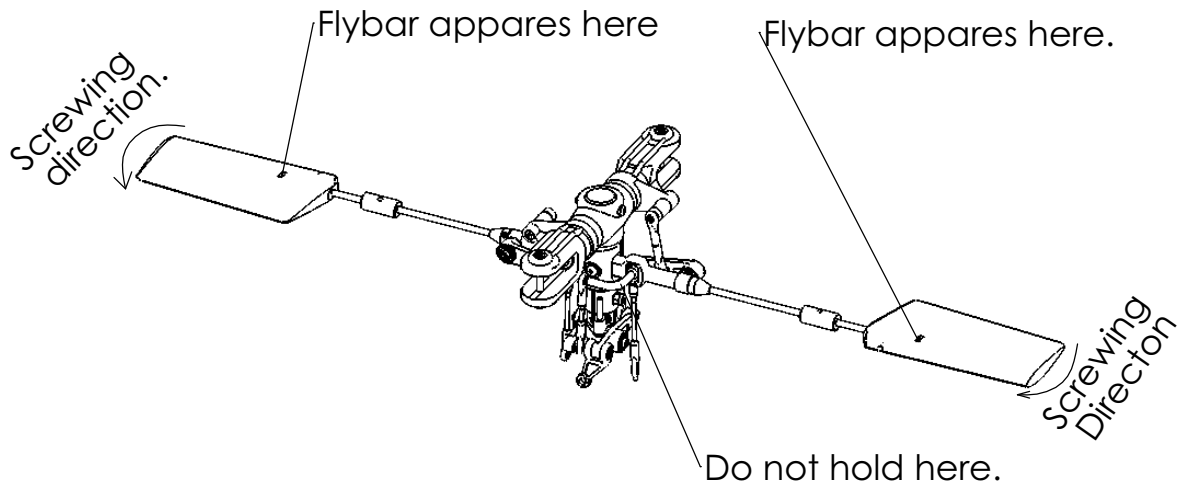

**Note: Don't hold flybar control arm as a wrench when you fix the paddle onto the flybar.**

b): Make sure the two **Paddles** are balanced to the center and fix the **Flybar Stopper**.

Make sure Two **Paddles** and two **Flybar Control Arm** are in the same Panel and fix the Flybar Control Arm.

Make sure the **Flybar Weight** are balance and fix the **Flybar Weight**.

Note: the longer the Flybar Weight away from the center, the more Stable the heli is.

Finally fix the set screw in the paddle.

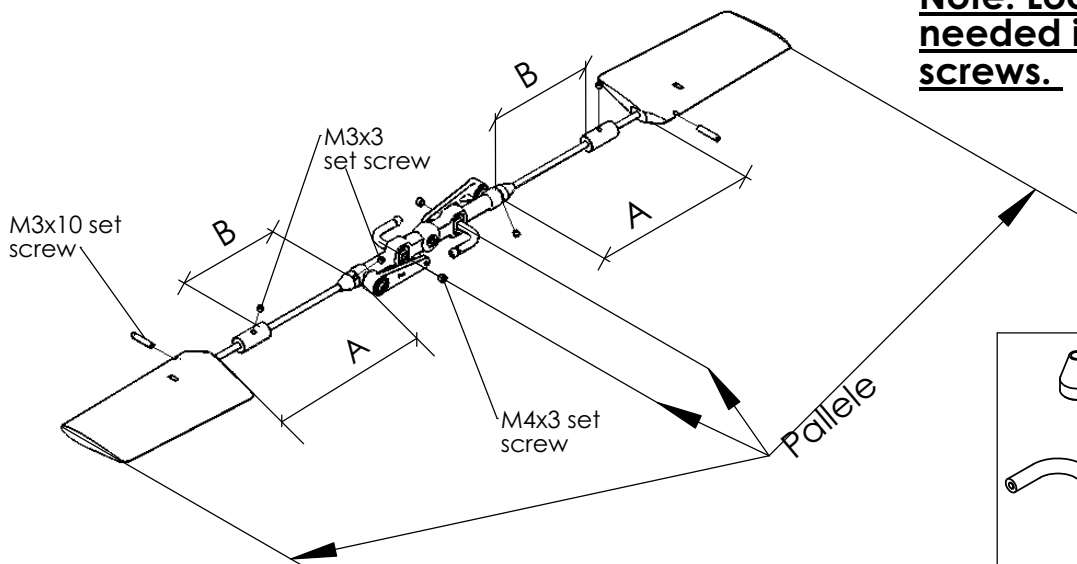

Flybar Stopper



Flybar Control Arm

## Step 3. Front Servo Mount



M3x20 Self Tapping  
Bolt x 6



M3x10 Self Tapping  
Bolt x 4

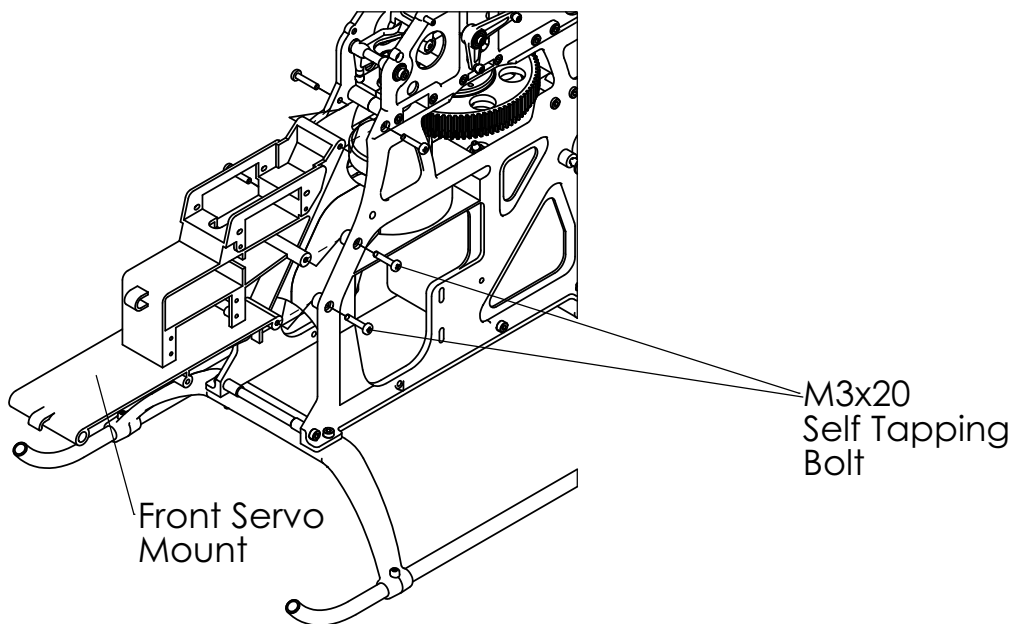

a) Use M3x20 Self Tapping bolts to fix the **Front Servo Mount** on the body.

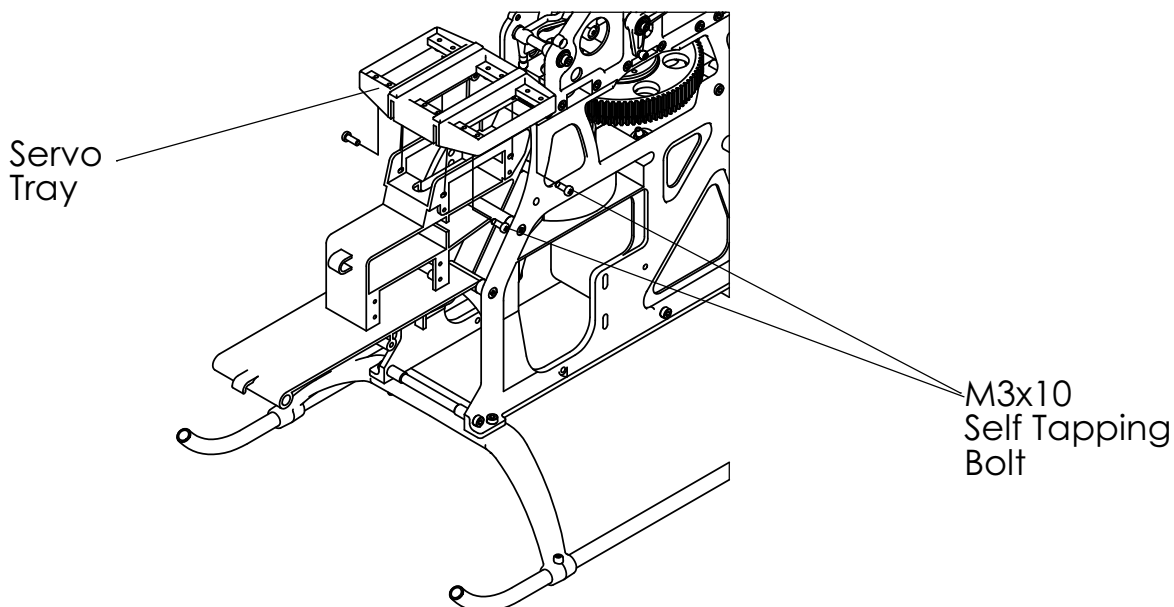

b) Use M3x10 Self Tapping bolt to fix the **Servo Tray** on the **Front Servo Mount**.

# Step 4. Install the Engine

		
M3x12 Socket head Bolt x 2	M3x16 Socket head Bolt x 8	M3 Washer x 4

a). Assembly **Cluth, Fly Wheel, Fan, Engine Mount** and the **Engine**.

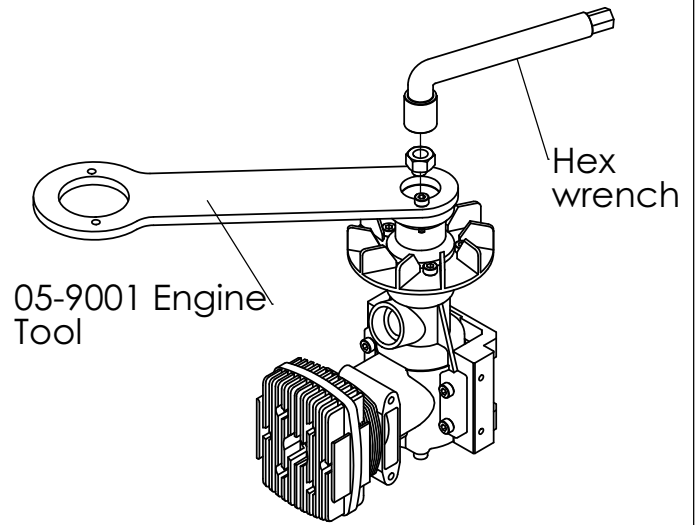
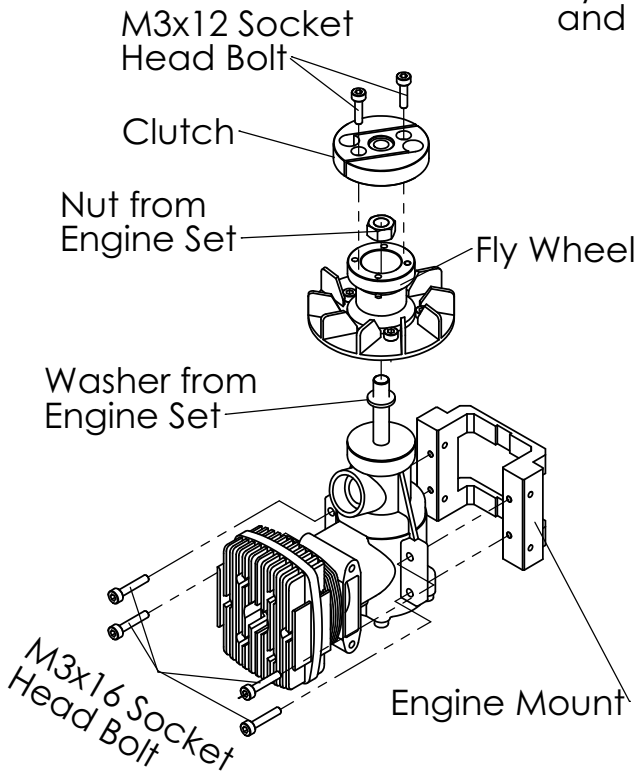

**Compass Engine Tool** is need to tight the enine on the Fly Wheel.

**Note: LOCKTITL SHOULD BE USED IN ALL SOCKET HEAD BOLTS HERE.**

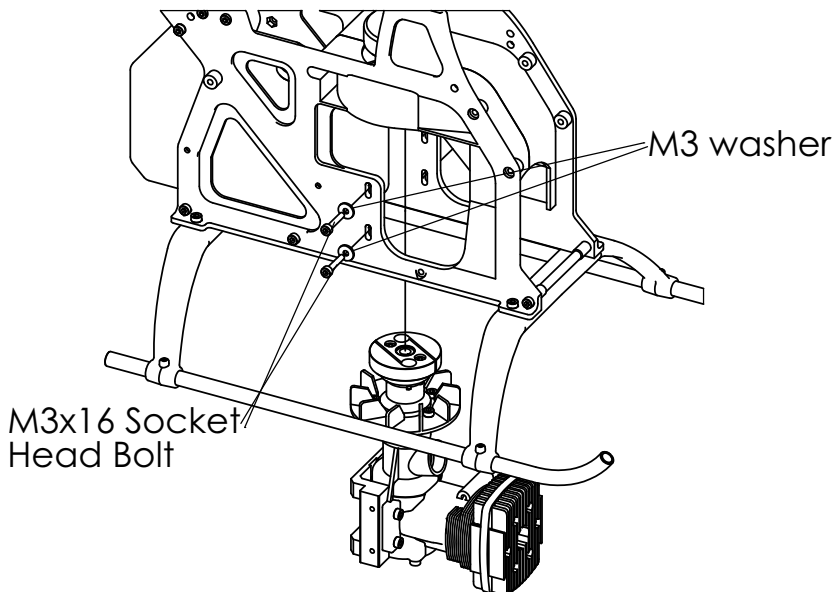



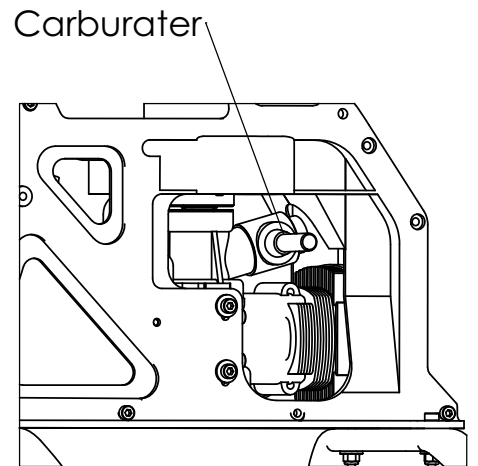

b). Insert the whole **engine set** and fix it on the body with M3 x 16 Socket Head Bolt and washers.



c). Finally install the **Carburater** on the **engine**, refer to engine manual.

# Step 5. Tail

			
M3x12 Socket head Bolt x 2	M3 Nylon Nut x 2		

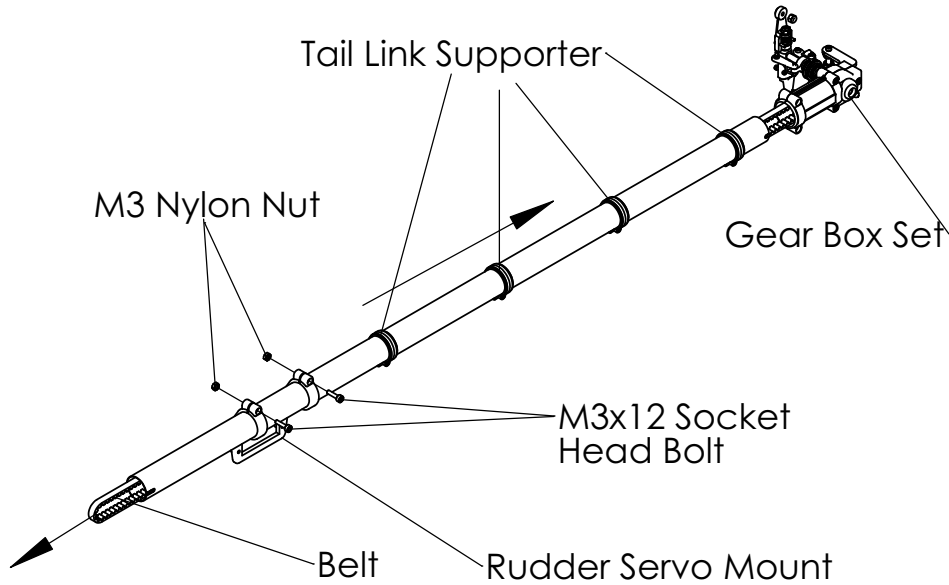

- (a) Insert the **Tail Boom** into the **Gear Box Set** until **Belt** go through the whole **Boom**. Install the **Tail Link Supporters** and **Rudder Servo Mount** on the **Boom**.

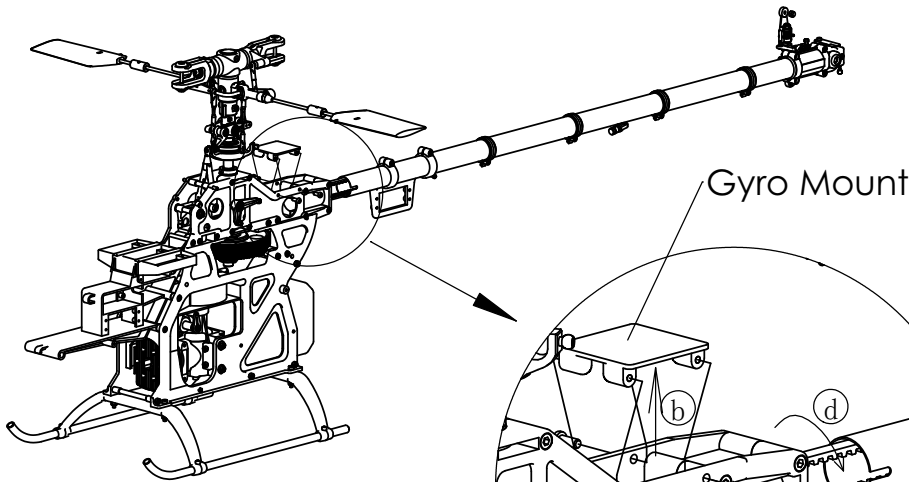

- (b) Remove the **Gyro Mount**
- (c) Insert the **Tail Boom** and **Gear Box**.
- (d) Turn the **Belt** 90° **clockwise**. (refer to the detailed view on left).

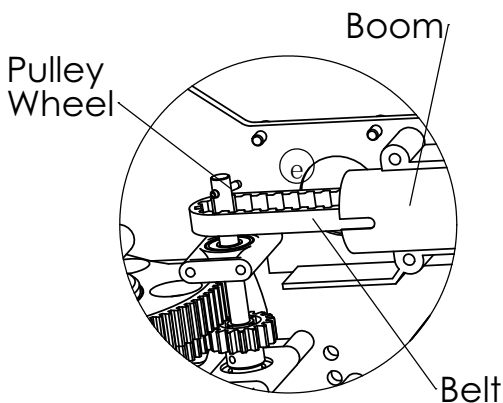

Inside the Frame

- (4) Install the **Belt** around the **Pulley Wheel**. reinstall the **Gyro Mount** afterwards.



## Step 6. Fins and Boom Supporters

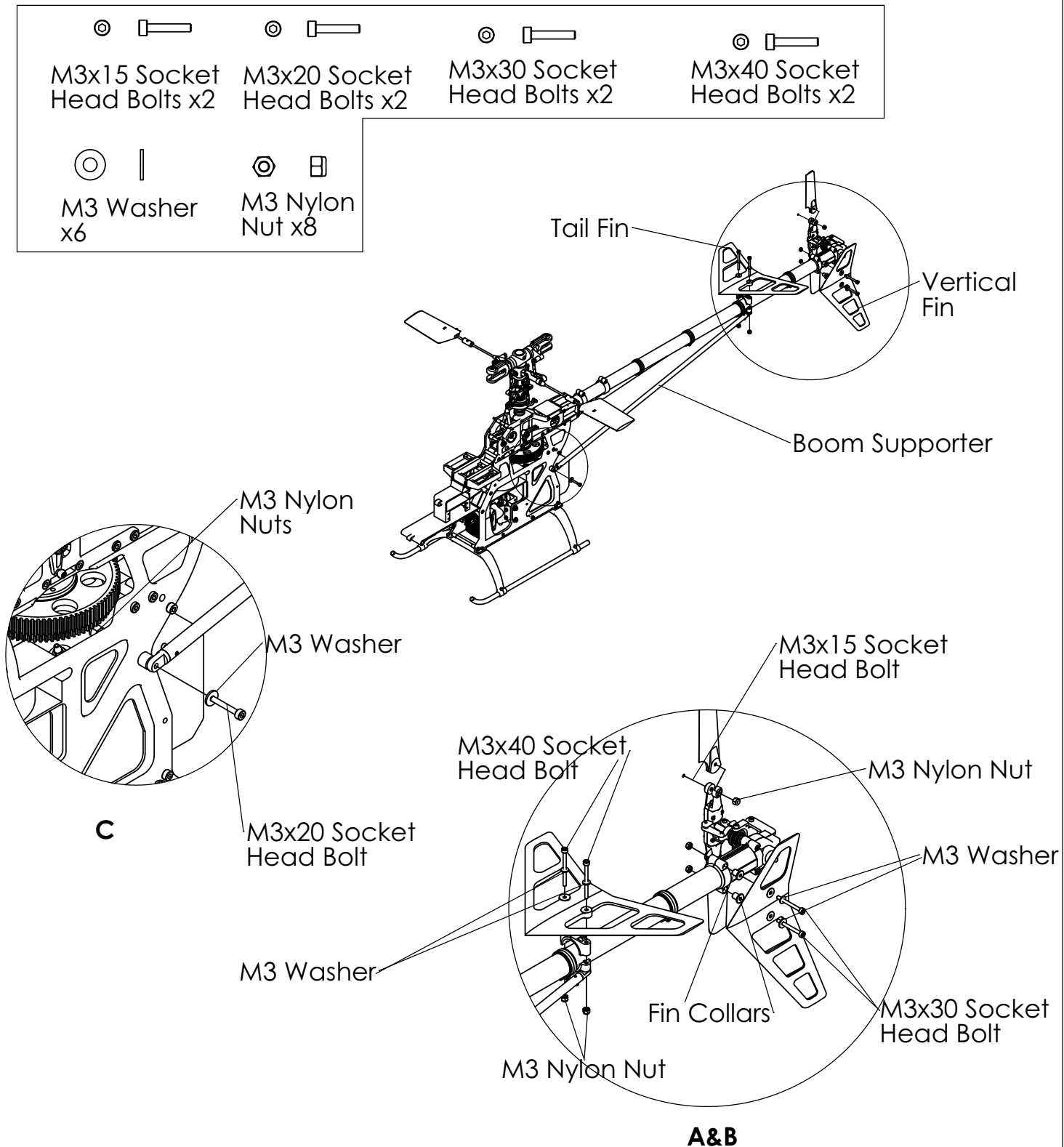

A: Tight up the **belt**, use M3x30 Socket Head bolt and M3 Nylon Nuts to fix the **vertical fin** and **Tail Gear Box** on the **boom**.

B: Use M3x40 Socket Head Bolts, washer and M3 Nylon Nuts fix the **Horizontal fin** and the **boom Supporters** on the **boom**. Use M3x15 Socket Head bolt and M3 Nylon Nut to fix the **Tail blade** on the **Blade holder**.

C): Use M3 Socket Head Bolt and M3 Nylon Nut to tight the **Boom Supporter** on the heli body.

## Step 7. Servos



M2x6 Socket  
Head Boltx5

M2.5x16 Self  
Tapping Bolt x20

M2.5 Washer x20

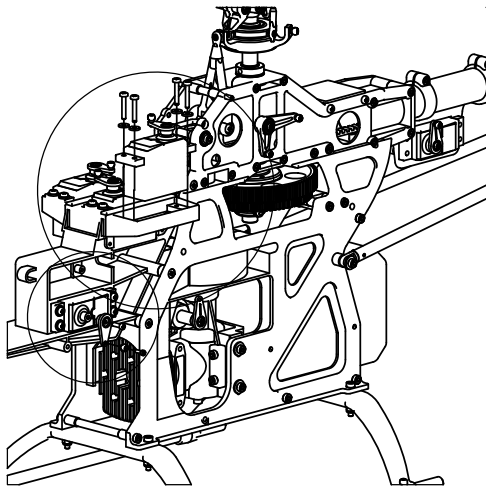

M2.5x16  
Self Tapping  
Bolt

M2.5 Washer

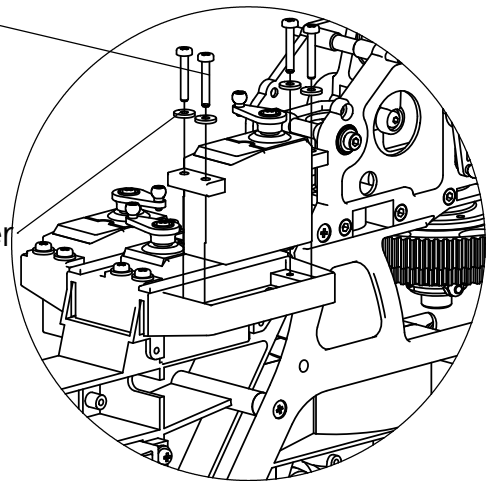

Servo Installation

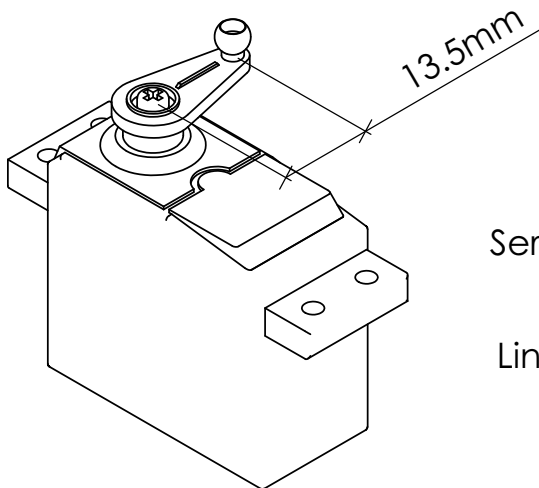

Servo Horn

Link Ball

Bolts come  
with the Servo

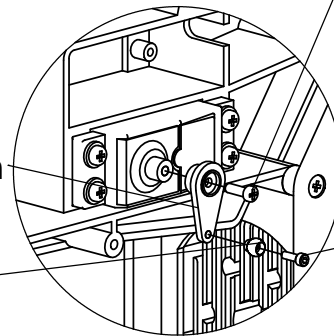

M2x6  
Socket Head  
Bolt

Servo Horn

a). Use M2.5x16 Self Tapping Bolts and Washer install **Servos** on the heli Body.

b). Use the self Tapping Bolt come from the **Servo** fix the **horn** on the **servo**.

c). Use M2x6 Socket Head Bolt infix the **link ball** on the horn. The distance between the **ball** centre and the **horn** centre is roughly 13.5mm.

## Step 8. Wire Up

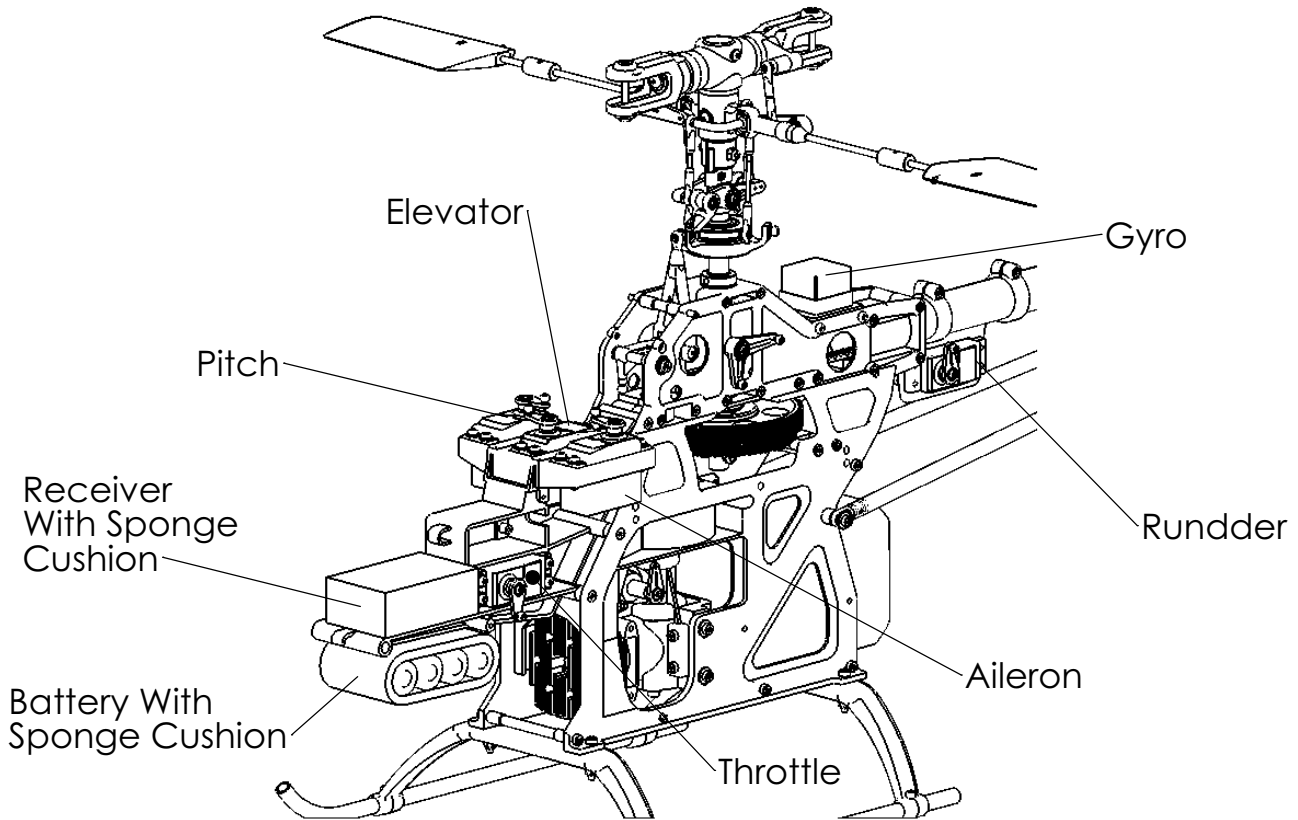

- Adhere **Gyro** on the **Gyro Mount**, detail refer to Gyro's manual.
- Use **Nylon Bandage** to tie Battery with Sponge Cushion on the front nose.
- Use **Elastic** tie Receiver with **Sponge Cushion** on the **front servo mount**.
- Connect **servos, gyro, battery** with **Receiver**, which **servo** goes where refer to radio manual.

## Step 9. Radius Stay Arm

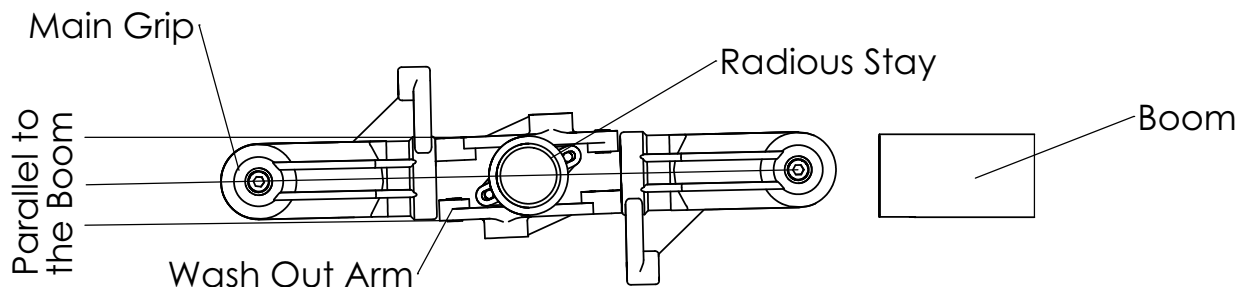

**Radius Stay Arm need to be at an angel so that Main Grips and Washer Out Arms are parallel to the Boom.**

## Step 10. Radio Setting Data

after installing Servo, Gyro and other electronics. Set up your radio with following data.

### Pitch Curve

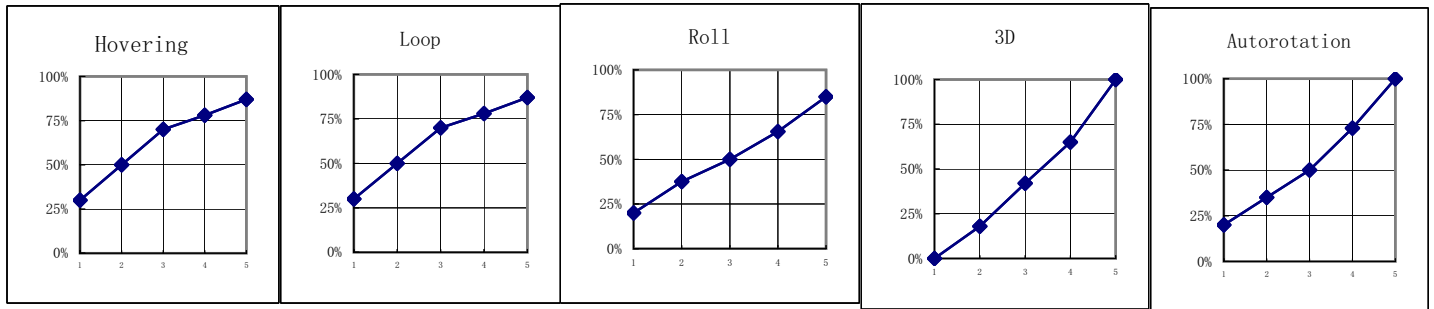

### Throttle Curve

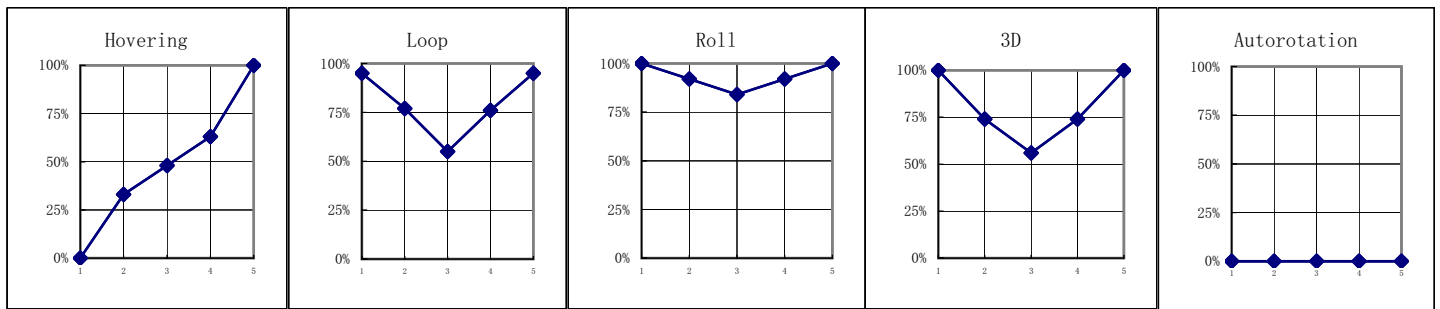

### Pitch Setting

	Hovering	ID1 Loop	ID2 Roll	ID3 3D	Autorotation
High Pitch	9~10	9~10	7	10	12
Hovering	5~5.5	3	0	0	N/A
Low Pitch	-4	-6	-7	-10	-7

### Swash Type Setting

JR		Futaba
Swash Type		SWH
S3 120°		SR2
Aile	Elev.	Pitch
70%	70%	55%

Above data just give some general idea of setting. It varies by engine, blades, muffler and pilot's style. Adjust by actual flight.

## Step 11. Set Up

- a) Turn on the radio and set throttle position to mid stick (middle position) For 0 deg. All three servo control horns must 90 deg to the zero edge. Use sub trim in radio program to adjust each servo to get control horn to the right angle.

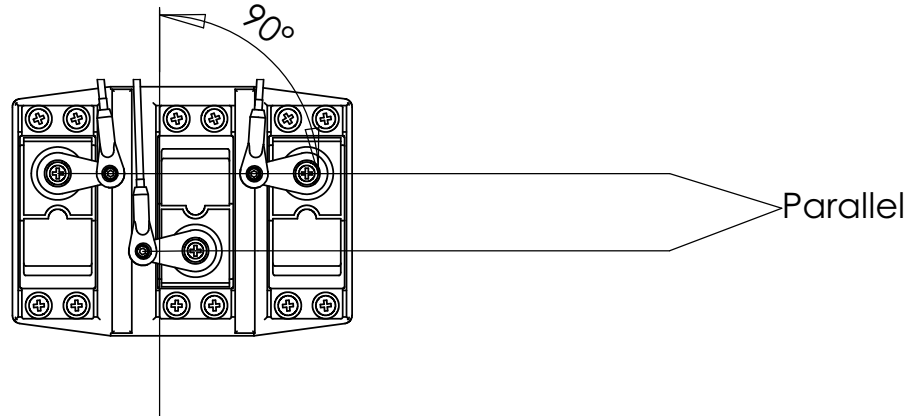

- b) next is to adjust links from servo to L arms (2 on outside of frame and 1 in the middle of the frame) so that the L arms are all Horizontal.

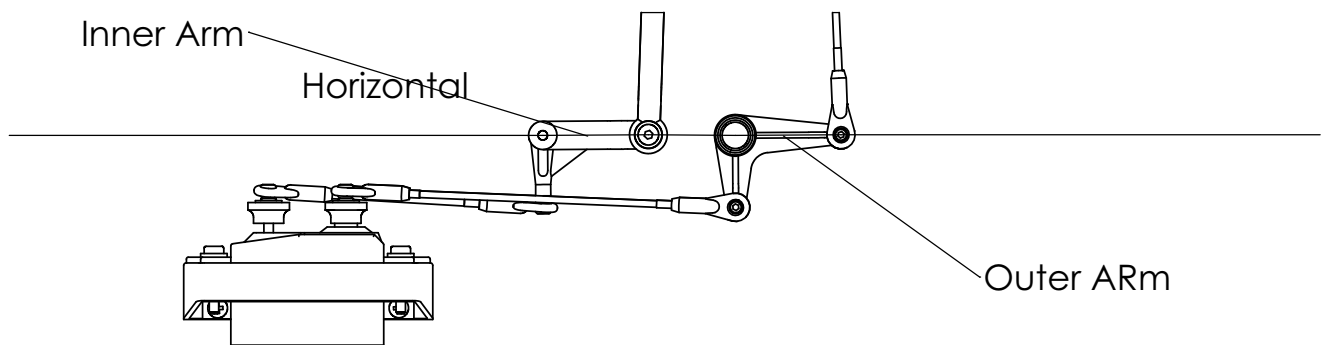

- c) next adjust the two side L arm links to swash plate to level swash plate. a compass tool can be used here to level swash plate.

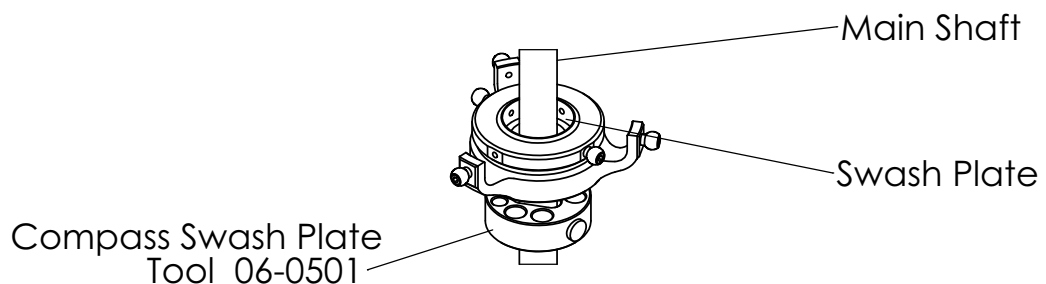

d) set the wash out control arm 90 deg to the main shaft.

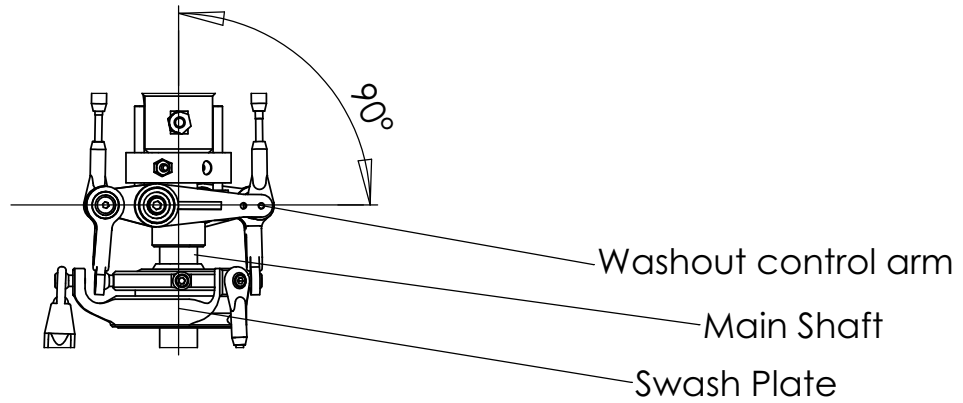

e). Set the mixing arm 3 deg. downwards to flybar so that the pitch link is 90 deg to the mixing arm.

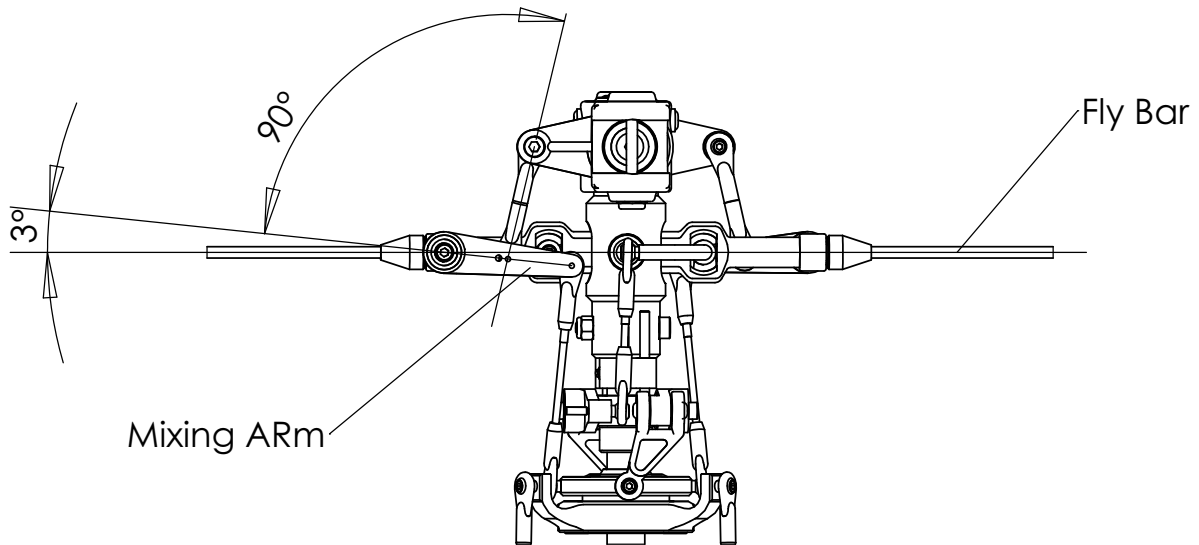

f). Install main blades and set to 0 deg pitch with the links on main blade Grips. One ball link might need to be cut shorter to set the pitch to 0.

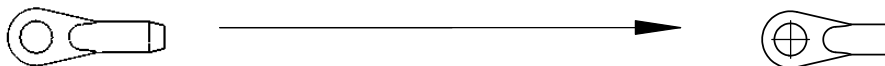

g). Install and adjust the engine link so that link is 90 deg to the sero horn and the engine horn.

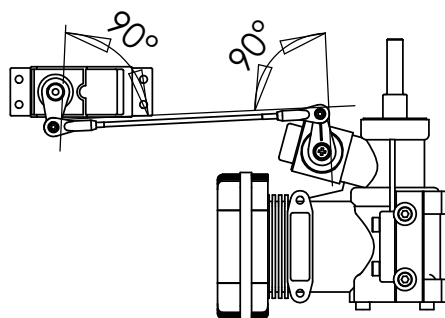

**Summary:**

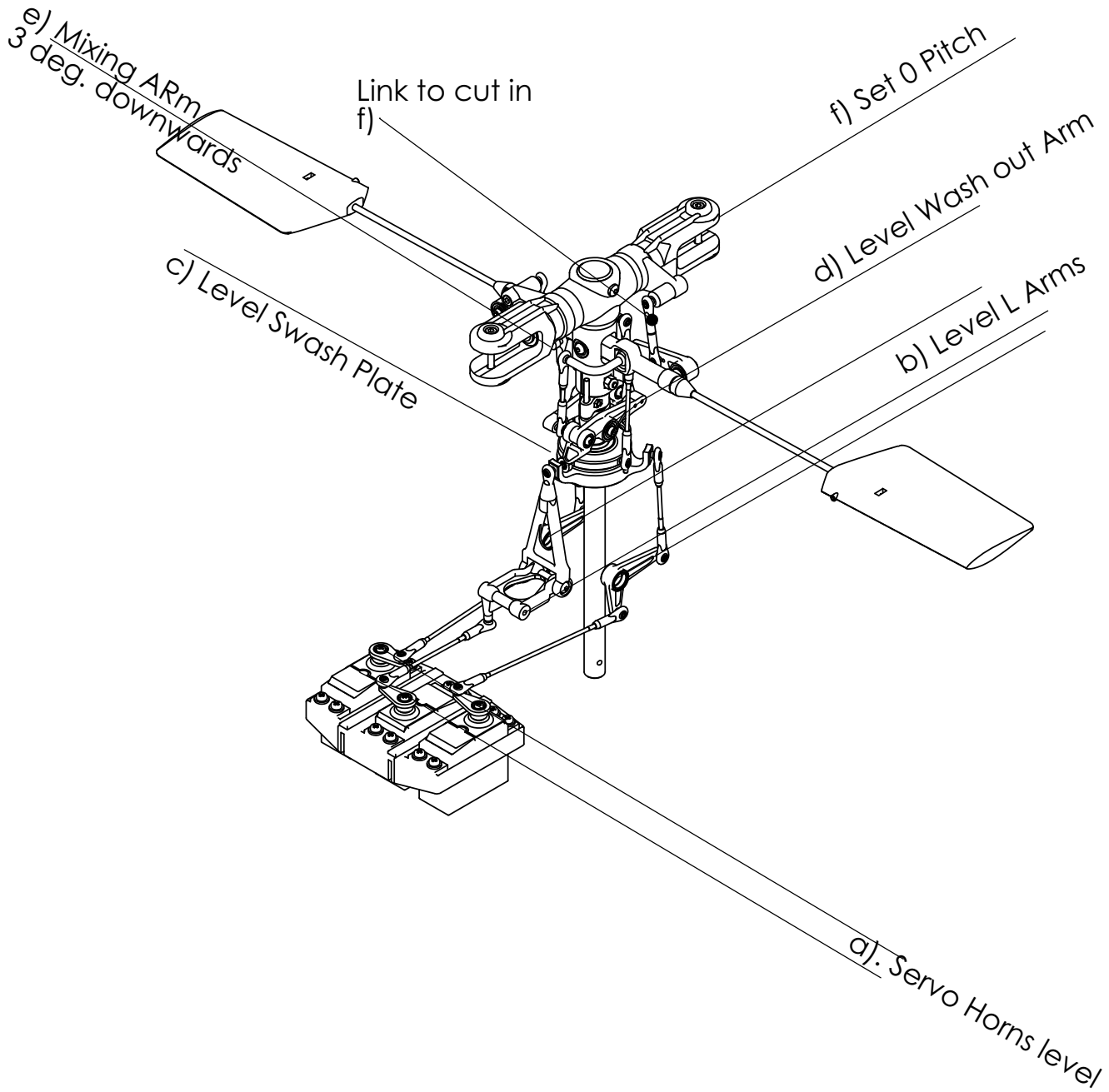

**Linkage Length**



All linkage length are measured in this way. In case you change ball links, you can set the same measurement.

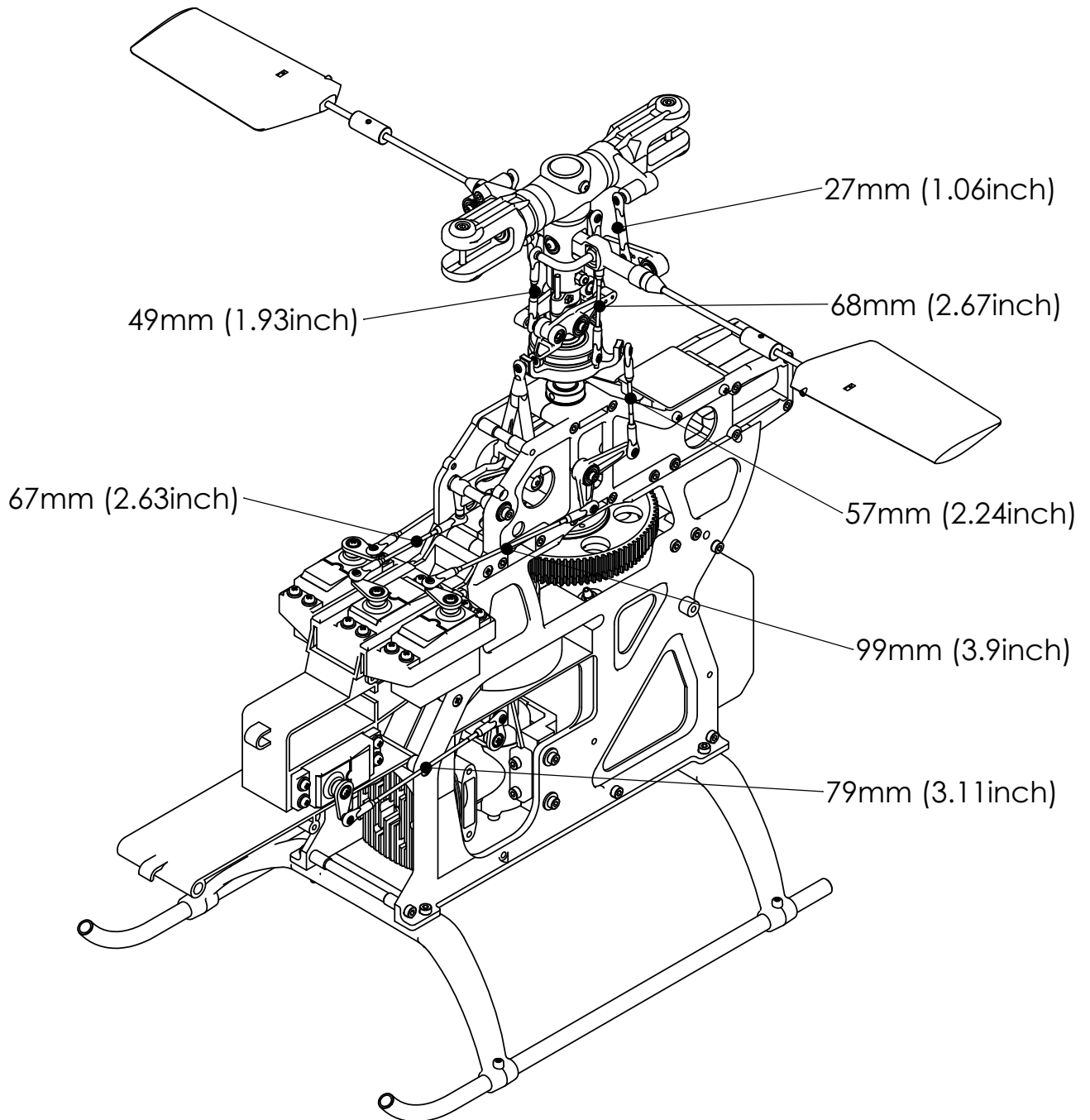

- Linkage Length 27mm (1.06 inch) x 2: main blade holder to mix arm
- Linkage Length 49mm (1.93 inch) x 2: fly bar control arm to wash out control arm
- Linkage Length 68mm (2.67inch) x 2: mixing arm to swash plate inner ring
- Linkage Length 57mm (2.24inch) x 2: swash plate outer ring to L arm
- Linkage Length 99mm(3.90inch) x 2: L arm to Horns of outer servos
- Linkage Length 67mm(2.63inch) x 1: front arm to horn of inner servo.
- Linkage Length 79mm(3.11inch) x 1: engine control



## Step 12 Canopy Mount

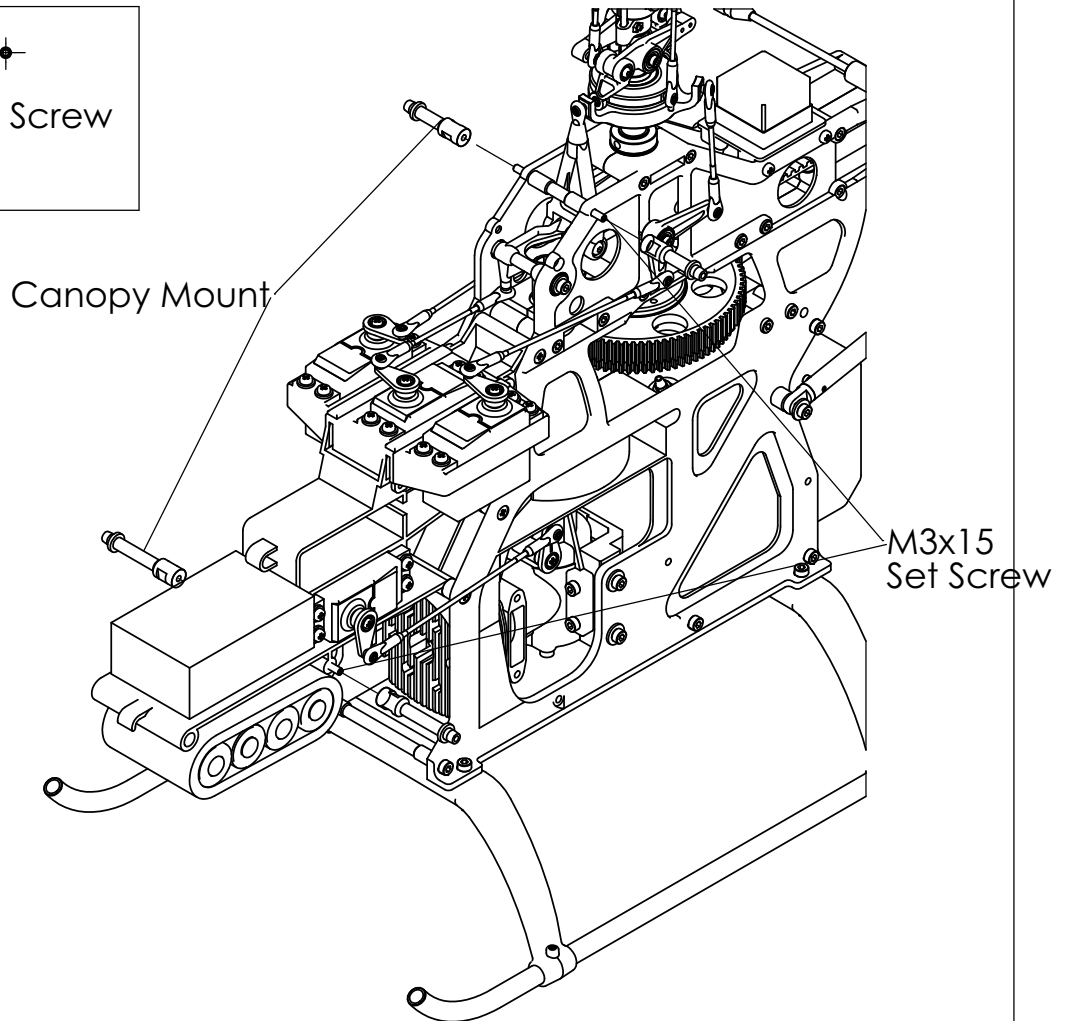
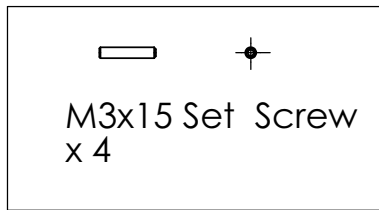

Use M3x15 Set Screws to install the 4 canopy mount on the heli body so that later the Canopy can be installed.

**Reminder:** The Bolts connecting the Main Grips to Spindle are normally Not Locktitled when out of box. Regular checks are needed to ensure the safety of flights.

Bolt here is not Locktitled when out box.

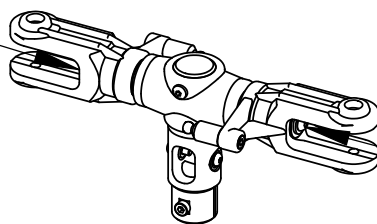

Bolt here is not Locktitled when out box.

## Step 13. Canopy & Check Turning Direction

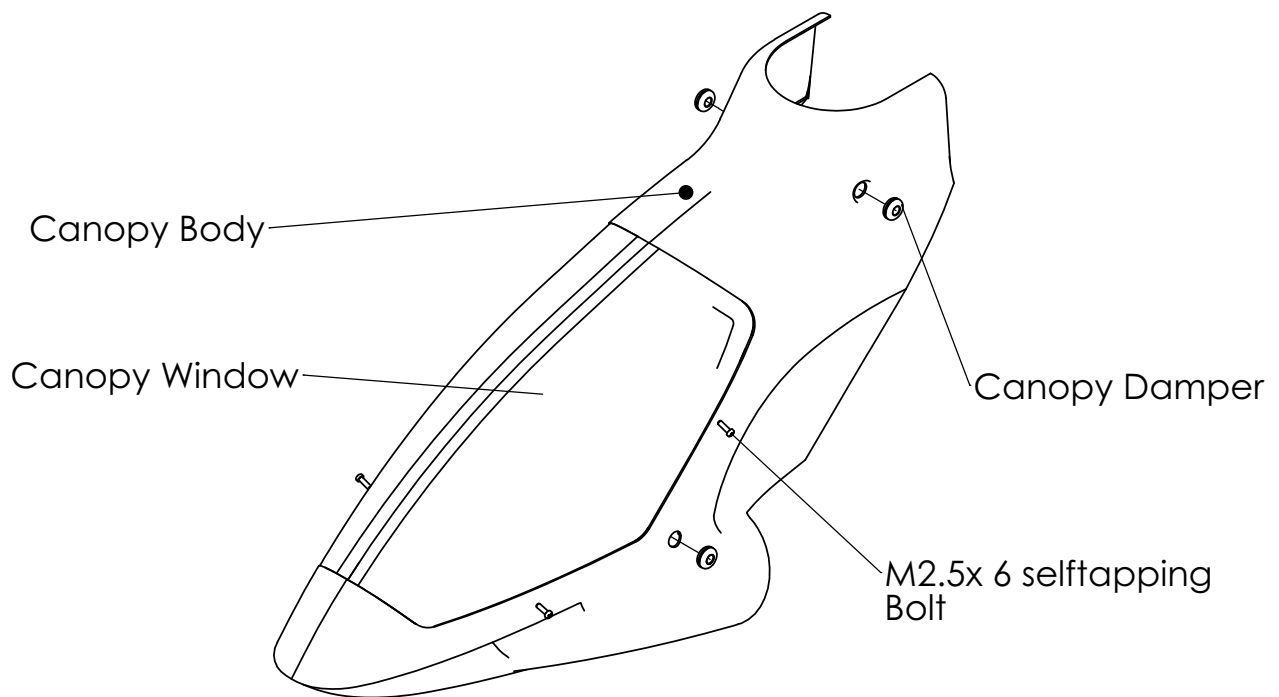

Note: Clean the canopy with Detergent or Soap Water before attaching the Decal on the Canopy.

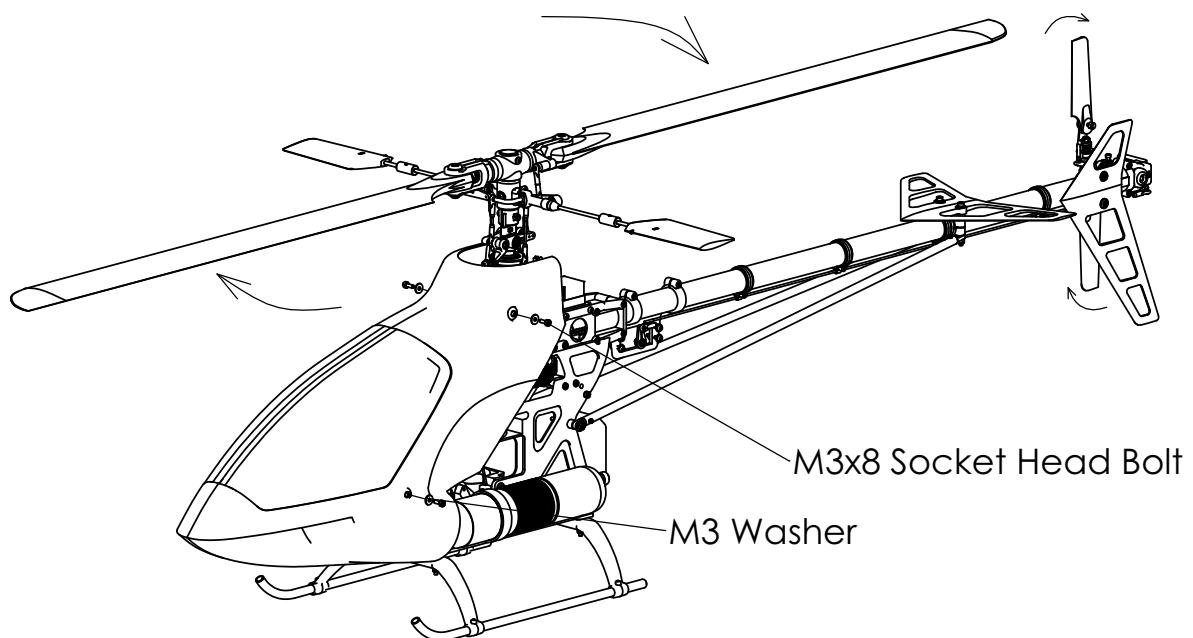

**When Main Blade turn clock wise, the tail blade should turn clockwise too. if not the Belt might be installed in wrong direction.**

# 关于贴纸 ABOUT THE DECAL

