

Instruction Manual For Century Hawk/Falcon SE

Building Tips

Rotor head and seesaw

Main blade grip & feathering spindle

Flybar washout & swashplate

swashplate, start shaft & bearing block

Tail drive pinion & counter gear

Main gear, slipper & elevator lever

Upper side frame assembly

Upper side frame

Collective and aileron levers

Clutch, Fan, engine & throttle lever mounting

Fuel tank & lower frame assembly

Servo frame assembly

Final rotor head & muffler

Landing gear & tail output shaft assembly

Tail control assembly

Tail blade grip setup

Tail drive shaft and pushrods

Tail gearbox & vertical fin

Tail boom final setup & horizontal fin

Pushrod setup

Initial radio setup

Servo setup and adjustments

Aileron & collective linkage

Rotor head and elevator linkage

Elevator linkage diagram

Throttle linkage and main blade installation

Canopy & decals

Radio components and balancing

Final radio adjustments

Pitch and throttle curves

Tail rotor setup

Before you fly

Starting the engine

Basic hovering

parts 1

parts 2

Building Tips for Assembly

Tip 1: Metal parts and fasteners generally have an oil residue coating for protection from rusting. This residue must be removed prior to applying any type of threadlocking agent or glue. Using regular household rubbing alcohol place a few drops on a rag or cloth and wrap the fastener and essentially unthread from your fingers. A black residue will remain on the cloth, repeat until no further residue can be removed. Do not use on ball bearings, these are factory lubricated and any cleaning can lead to early failure. To prepare for installation, use a dry cloth and clean all metal surfaces that will be assembled along with the fasteners for that step.

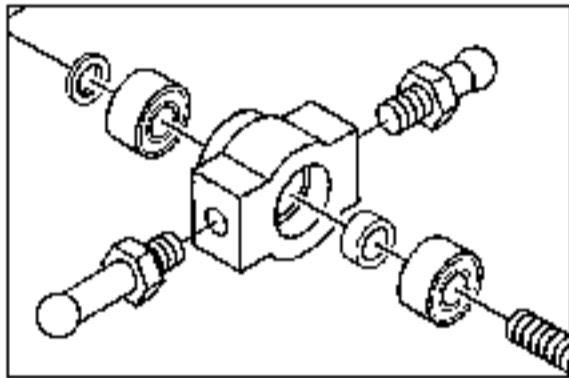
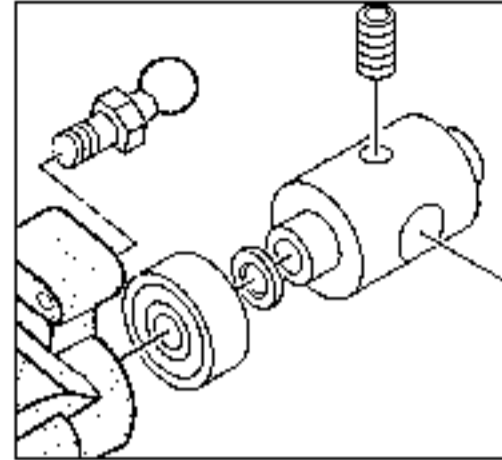

Tip 2: In many locations in the assembly steel balls need to be threaded into plastic parts. To make this an easier task, use an available 3x16mm socket cap screw with a hex key and tap the threads ahead of time. When tightening the steel ball, use an open ended metric 5 wrench which will match the hex exactly and not damage the ball. Standard pliers can easily slip and scratch the surface of the ball which will prematurely wear the plastic ball links.

Tip 3: For self tapping screws into plastic parts, again use an available 3x16mm socket cap screw and tap to a depth of 1/2 the length of the screw to be used. For extra security on self tapping screws apply a small drop of epoxy to the screw threads before inserting into the hole. The epoxy will bond to the plastic yet will allow removal of the screw later.

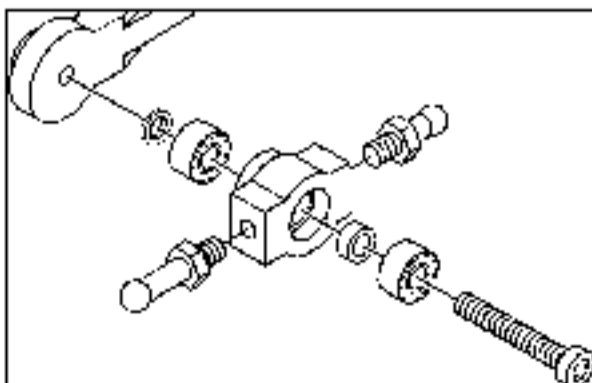
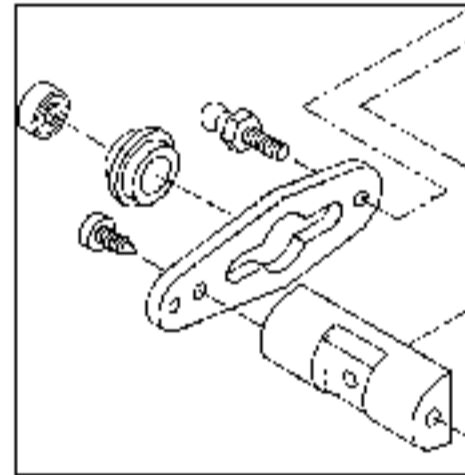

Tip 4: For machine screws, tap the hole ahead of time using the screw being careful not to strip out the threads as in some locations the plastic hole has a bottom. Finally assemble the parts for that step. Remember that machine screws can load bearing if overtighten. In these cases carefully tighten the machine screw then back of 1/16th of a turn.

Step 1 Main Rotor Head

From parts bag 1, press in the Damper Rubbers and the Guide Pins into the Head Block. Apply one drop of medium CA glue after the pins are fully seated. Install one 3x10 ball bearing onto each side of the seesaw shaft and insert into the Head Block. Fasten the two M3x6 self tapping screws (**Tip 3**).

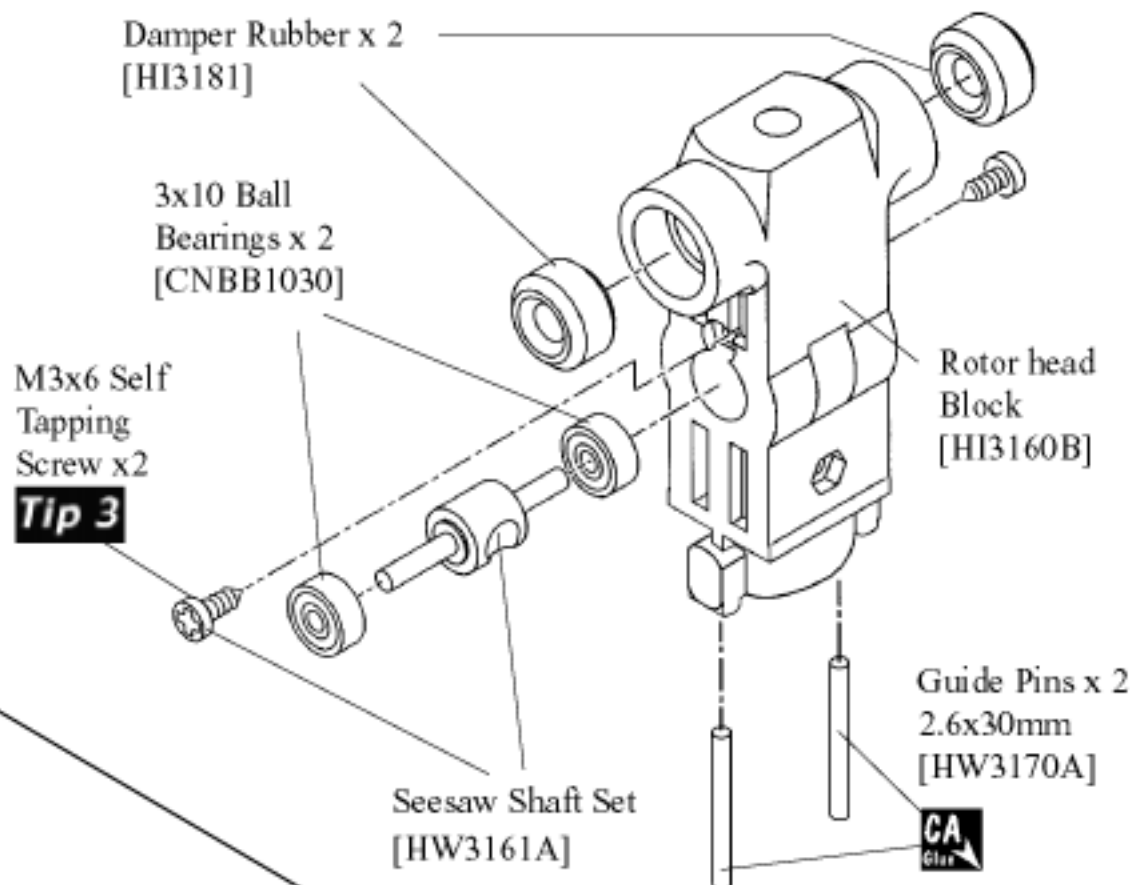

Step 2 Seesaw Assembly

From parts bag 1, insert one ball bearing into each bearing cup and insert into the offset plate. Following the numbered order, thread one M3x6 self tapping screw (**Tip 3**) and one M3x6 Special ball (**Tip 2**) through the offset plates into one tie bar. Slide the assembly onto the seesaw shaft and attach the other tie bar from the opposite side.

Bearing Cup x 2 [HI3167D] - 30

Bearing Cup x 2 [HI3167F] - 46

Special Ball x 2 [HI3167E]

Tip 2

Rotor Head from Step 1

Outside hole on offset plate is not used.



Follow steps 1, 2, & 3.

Tie Bar x 2 [HI3167C]

3x7 Ball Bearing x 2 [CNBB0730] - 30

4x8 Ball Bearing x 2 [CNBB0840] - 46

Offset Plate x 2 [HI3167B]

M3x6 Phillips Machine Screw x 2 [HI3167E]

Tip 3



Take notice of the location of the two steel balls on the offset plates.

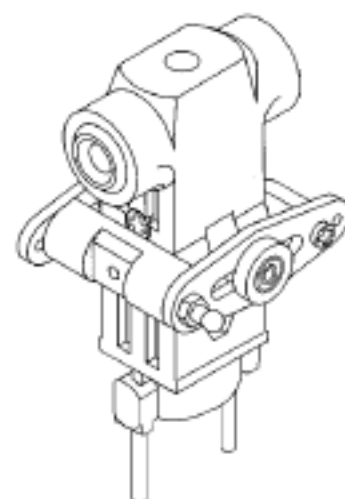

Completed rotor head.

STEP 3 Main Blade Grip Assembly



Note, the long ball is installed pointing away from the **top** of the blade grip.

From parts bag 1, install one Long Ball and one Short Ball (**Tip 2**) into the Bell Mixer, press one 3x7mm Ball Bearing into one side followed by one 3x5mm spacer and the one more bearing from the opposite side. Insert one M3x16 Socket Cap Screw (**Tip 4**) through the arm (make sure the flush side faces out) with one 3x5x0.5 Washer being careful not to overtighten the screw. Install two M6x13 Ball Bearings into both ends of the blade grip assembly. Complete the second blade grip in exactly the same way.

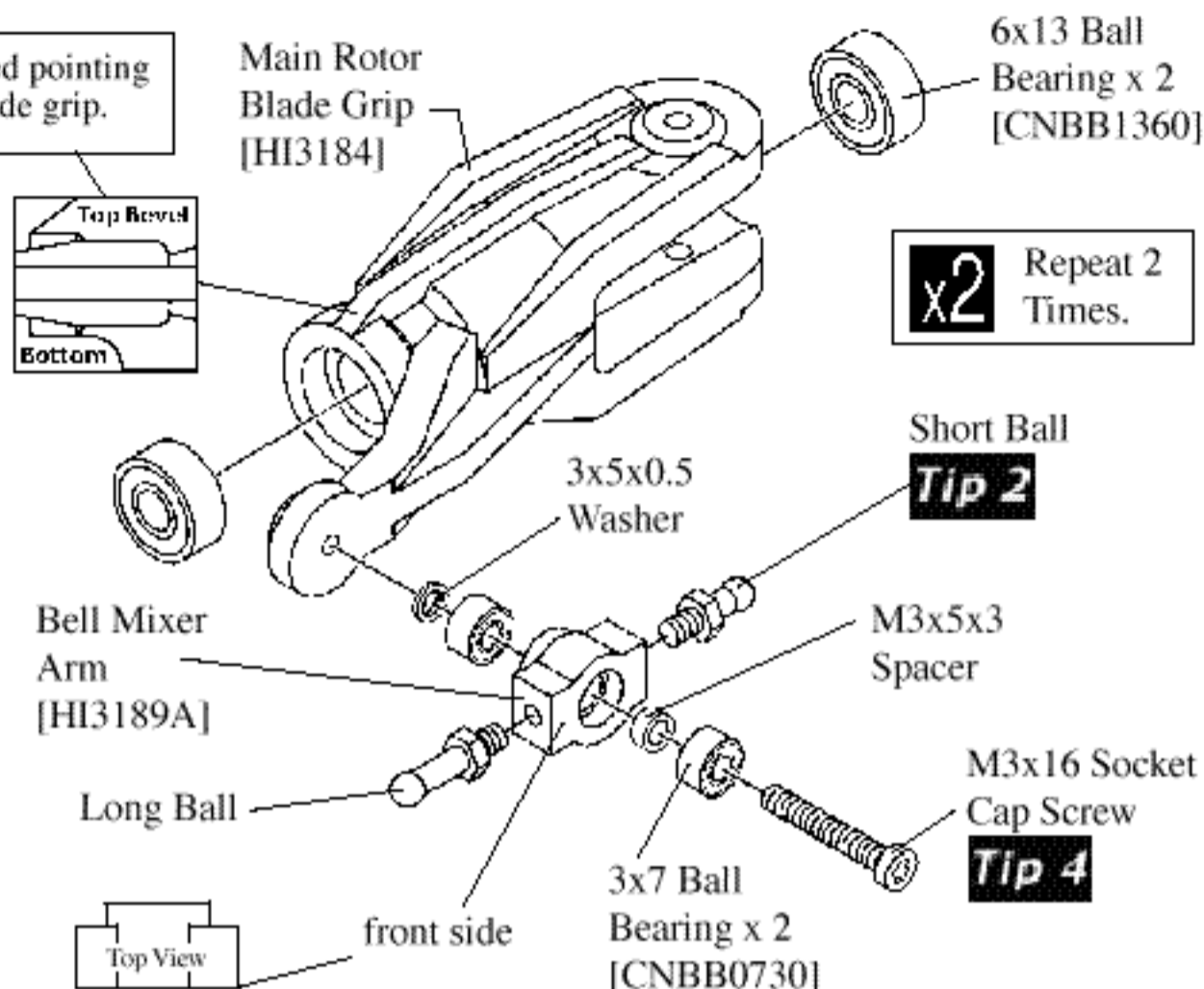

STEP 4 Feathering Spindle & Blade Grip Assembly

From parts bag 1, insert the Feathering Shaft into the head block, slide one 6x10mm Washer on each side of the shaft. Install the blade grip (**Note the direction of the bell mixer arm**) followed by one 8x13mm Washer, one 6x12 Thrust Ball Bearing (**install the first steel washer (large inside diameter) followed by the ball race, remember to grease the ball race, followed by the second steelwasher (smaller inside diameter)**) and one 5mm Locknut. Tighten the locknut, using the glow plug socket wrench on one nut while holding the other with pliers, tighten the nuts until both blade grips turn freely without any excessive end play. Assemble Pushrod 1 x 2, measuring 35mm end to end following the diagram on page 25, and connect the seesaw arm to the long ball on the bell mixer.



Top of blade grip has Bevel.

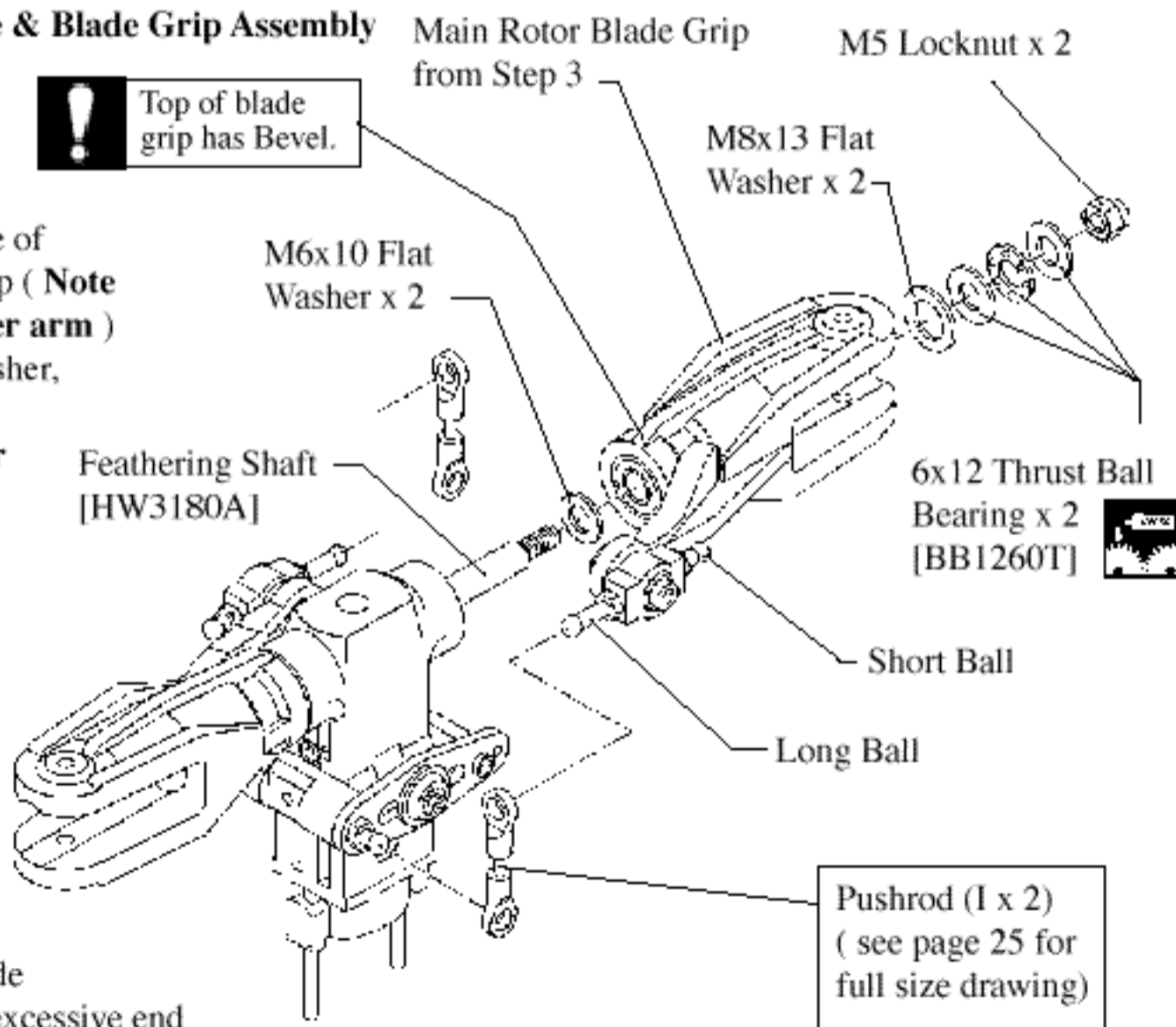

STEP 5 Flybar and Paddle Assembly.

From parts bag 1, slide and center the Flybar through the seesaw arm assembly. Install one Steel ball onto each flybar control arm with one 2x10mm phillips screw (**Tip 2**: the hole on the flybar control arm may too small, open slightly before inserting 2x10PH screw (**Tip 2**)). the hole on the arm is slightly too small, open slightly before inserting the screw, slide the Spacer, Flybar Control Arm on the flybar. Loosely tighten the control arms. Using a ruler, check the distance between the end of the flybar and the control arm and adjust until the lengths are the same and there is no free play between the control arms and the rotor head. Remove one set screw at a time, apply threadlock (**Tip 1**) and tighten in place. Slide the Flybar Weight (**Tip**: the flat end of the weight faces the paddle) and thread on the Flybar Paddle until all the threads are covered onto the flybar and align the paddles parallel. Again using the ruler, rotate one paddle or the other to get equal distances, remember leading edge of the paddles turn clockwise. Using two 3x3mm Set Screws secure the weights using threadlock.

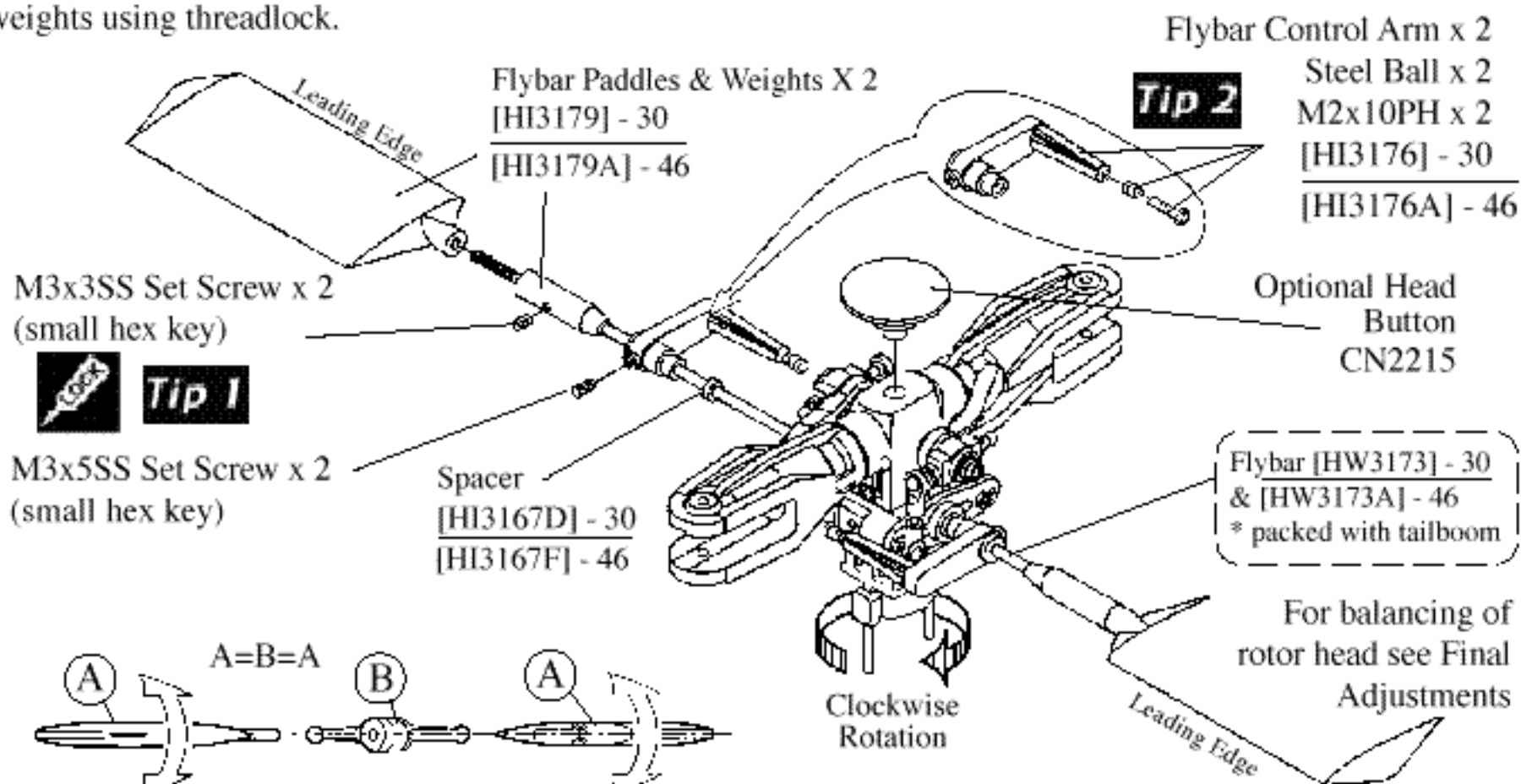

Align each paddle 'A' to be parallel with the flybar control arms 'B'. This is made very simple with the optional pitch and paddle gauge CN2026

STEP 6 Washout & Swashplate Assembly

Attach two Medium Balls (**Tip 2**) to the Washout Mixing Arms (**Note, attach from the flat side of the arm**). Press one 3x7mm Ball Bearing into one side followed by one 3x5mm spacer and one more bearing from the opposite side. Slide one M3x16 Socket Cap Screw through the bearings in the arm and slide one 3x5x0.5 washer between the bearing before tightening into the washout hub (**Tip 4** - note, use the right side hole on the hub. Press the radius link on to the inner short balls on the Swashplate.

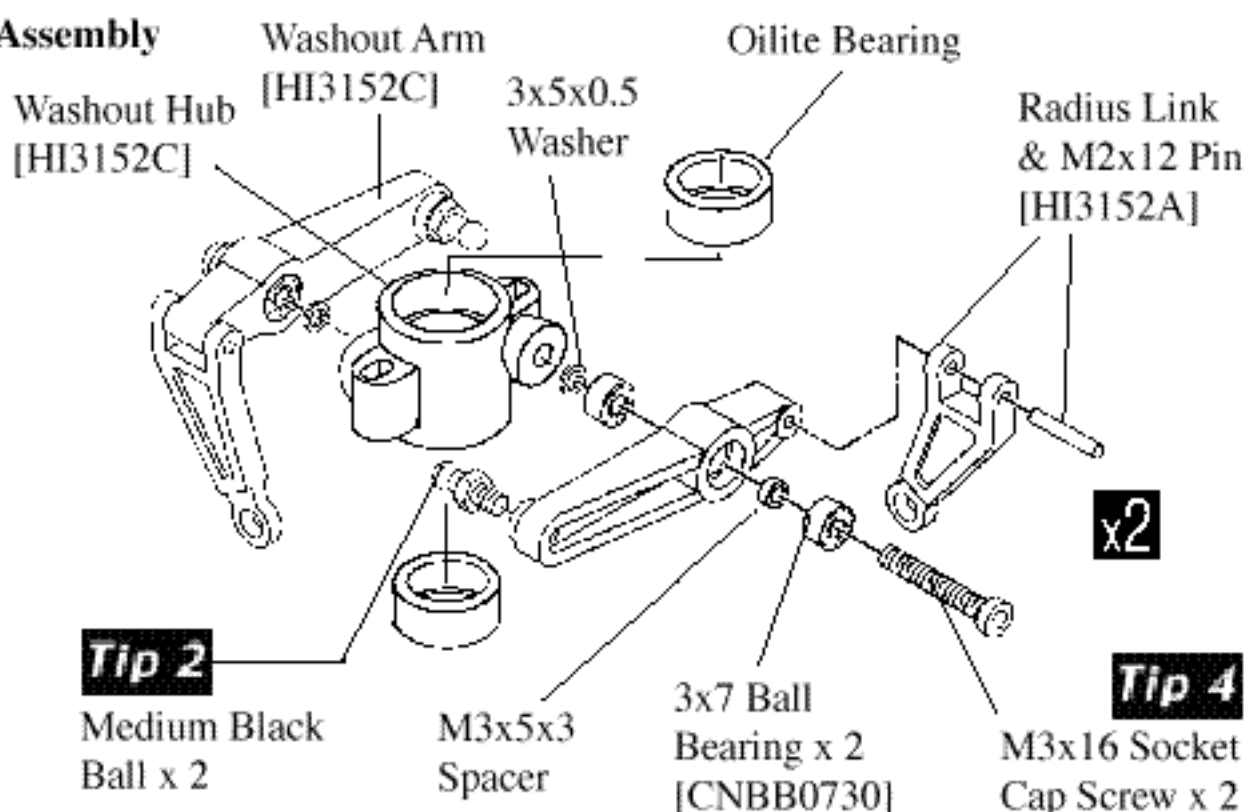

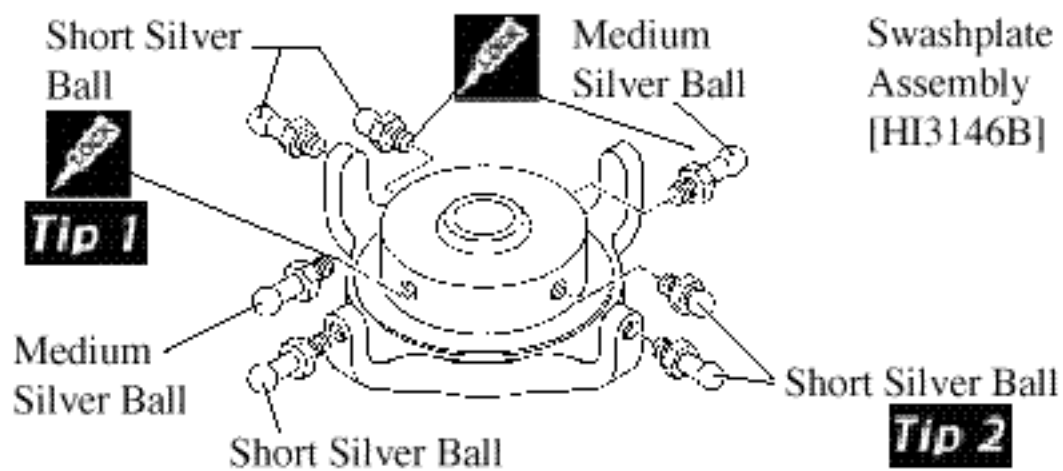

Step 7 Swashplate Assembly

Starting with the inside race, apply threadlock and attach two short balls (*Tip 1*) directly across from each other, similarly attach two medium balls to the remaining holes. Attach the three short balls (*Tip 2*) to the outside race. The rear location is not used now.

Step 8 Starting Shaft Bearing Blocks

From parts bag 2, the Start Shaft Guide Blocks are pre-assembled. Slide the Starter Shaft through one of the block assemblies with the M5x11 Ball Bearing facing up and slide the spring and 5mm Washer onto the shaft.

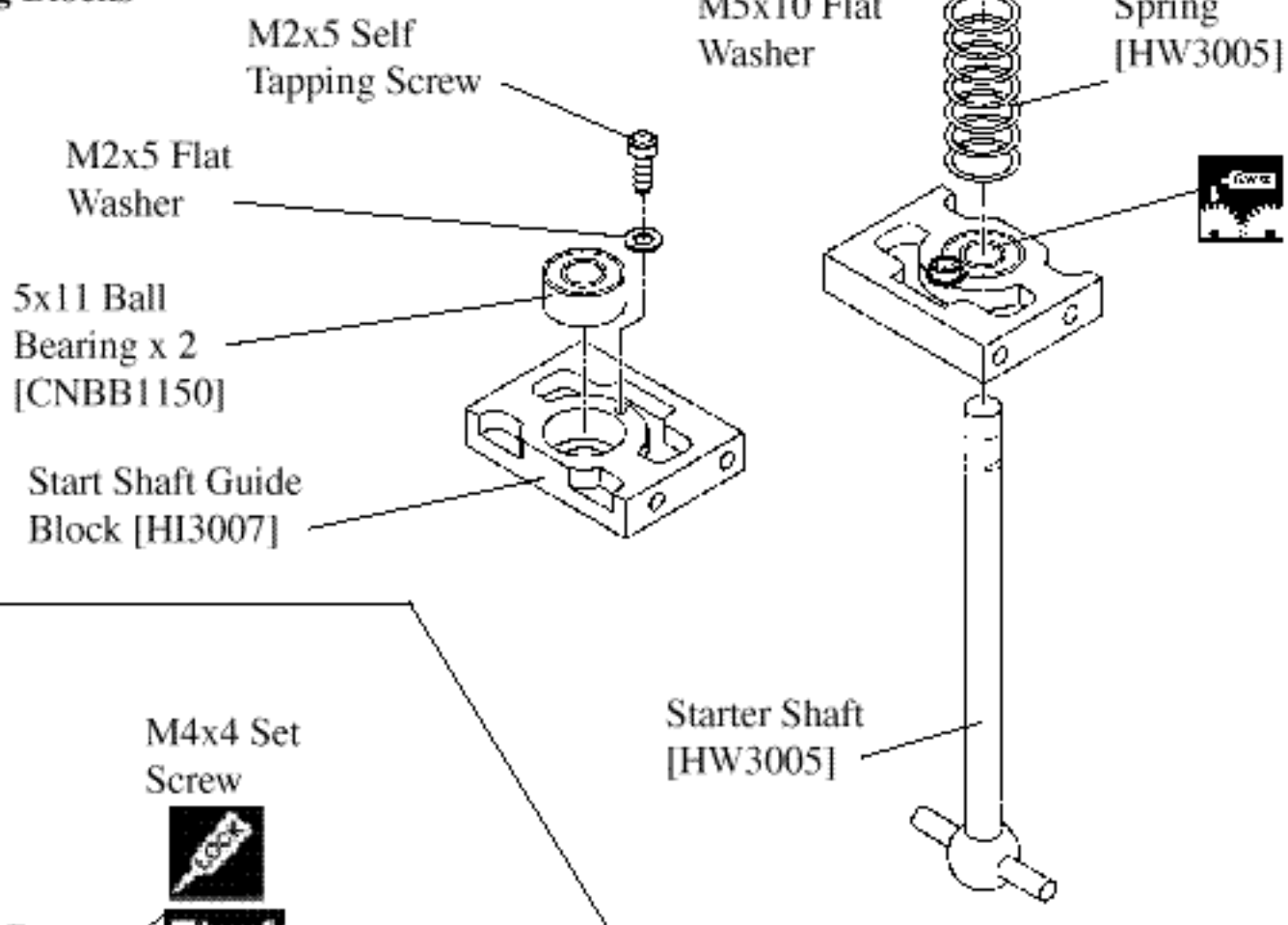

Optional:
Aluminum
Start Cone
#CN2209

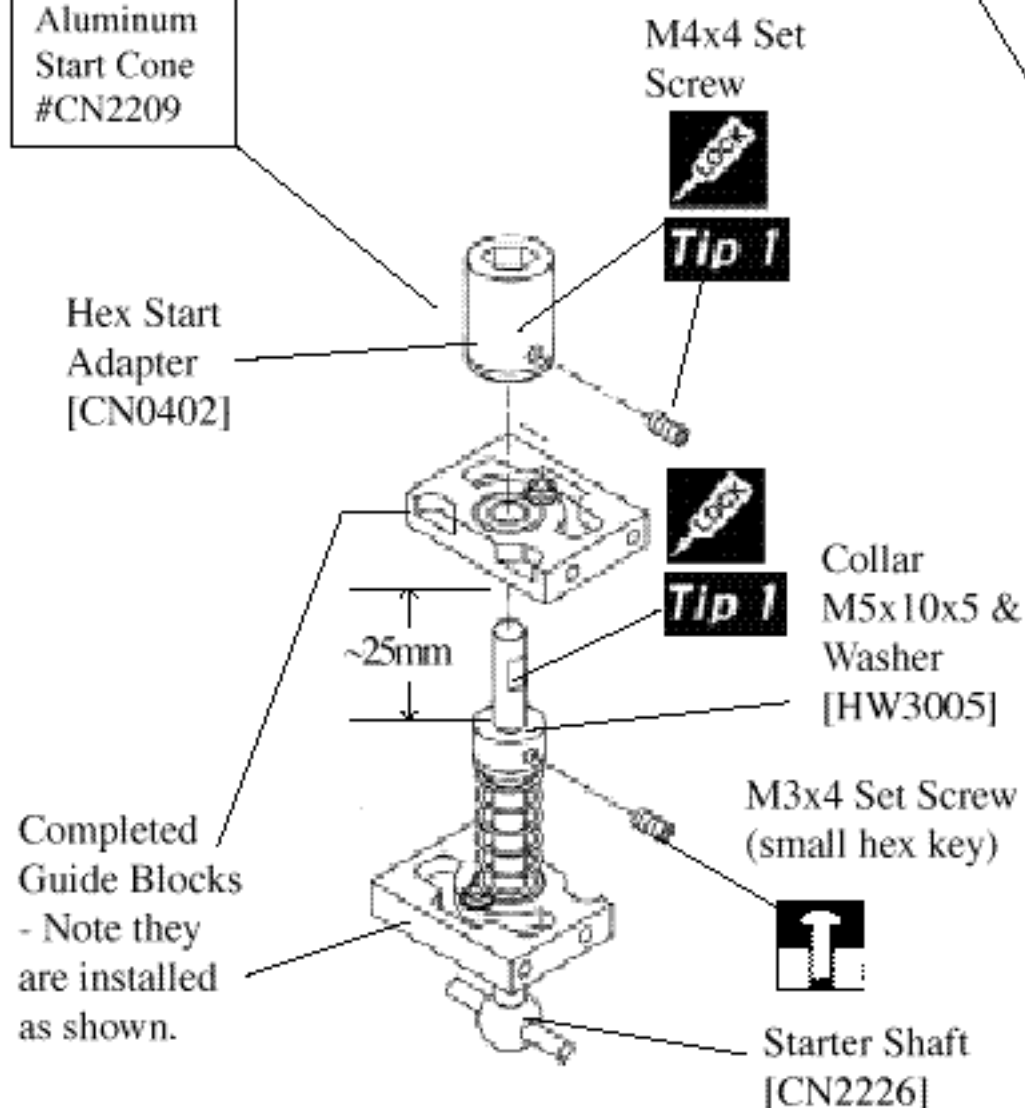

Step 9 Starting Shaft

From parts in bag 2, slide the M5x10 Collar spaced approximately 25mm from the top of the start shaft and partially tighten with one M3x4 Set Screw. (After the engine assembly is installed the position on the start shaft will be adjusted to allow the starting shaft to disengage from the cooling fan.) Assemble the hex starter adapter by installing the second Guide Block onto the start shaft, insert the M4x4 set screw through the hole in the side of the Hex Adapter, finally secure with one M3x6mm Washer Head Screw (*Tip 1*) from inside the Hex Adapter and Starter Shaft using some threadlock. Apply some lubricant on the shaft after assembly to ensure smooth operation.

Step 10 Tail Drive Pinion Gear

From parts bag 2, assemble the Tail Transmission Output Gear. Install the E-Ring then slide two Ball Bearings onto the Tail Rotor Output Shaft. Insert one 3x4mm Set Screw (*Tip 1*) using threadlock into the gear, note where the flat spot is on the shaft and slide the gear on and tighten the set screw (**Make sure the set screw is positioned over the flat spot**).

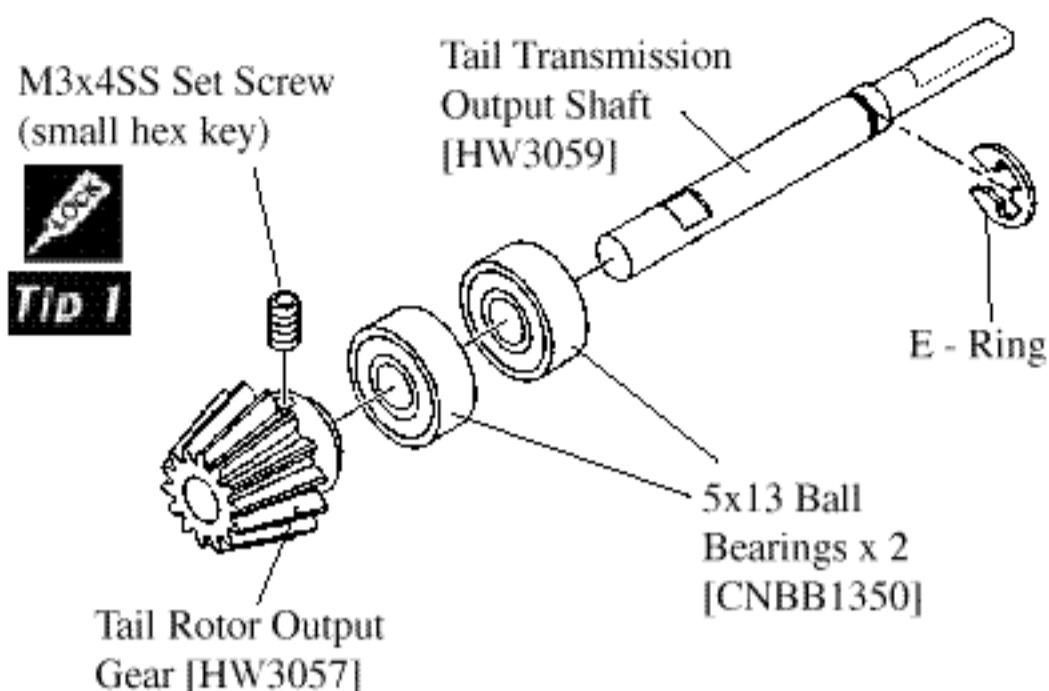

Step 11 Counter Gear Assembly

From parts bag 2, assemble the engine drive gear assembly, start by pressing the guide pin into the hole in the end of the Drive Shaft. Insert the shaft through the Counter Gear (**make sure the pin is fully seated in the recessed side of the gear**) then slide the two M5x13 Ball Bearings followed by M5x7 spacers. Insert one 3x4mm Set Screw (*Tip 1*) into the Alloy Drive Gear, then slide the gear onto the shaft taking care to position the set screw over the flat spot on the shaft.

Tip 1 Test fit the gear assembly into one half of the upper side frames. While holding the pinion gear, try to slide the counter gear up and down on the shaft. The gear should not slide up the shaft, if it does, readjust the top pinion to remove the slop and re-tighten the set screw using threadlock. It is important that there is no free play but the bearings are turning freely when assembled. Apply a small amount of red locktight to the top of the counter shaft and insert into the pinion gear.(not the set screw).

Tip 2 Expert tip, once all components are in their final position, using a needle apply one drop of blue threadlock carefully at the joint between each bearing and the shaft. **Warning**, threadlock will damage a bearing.

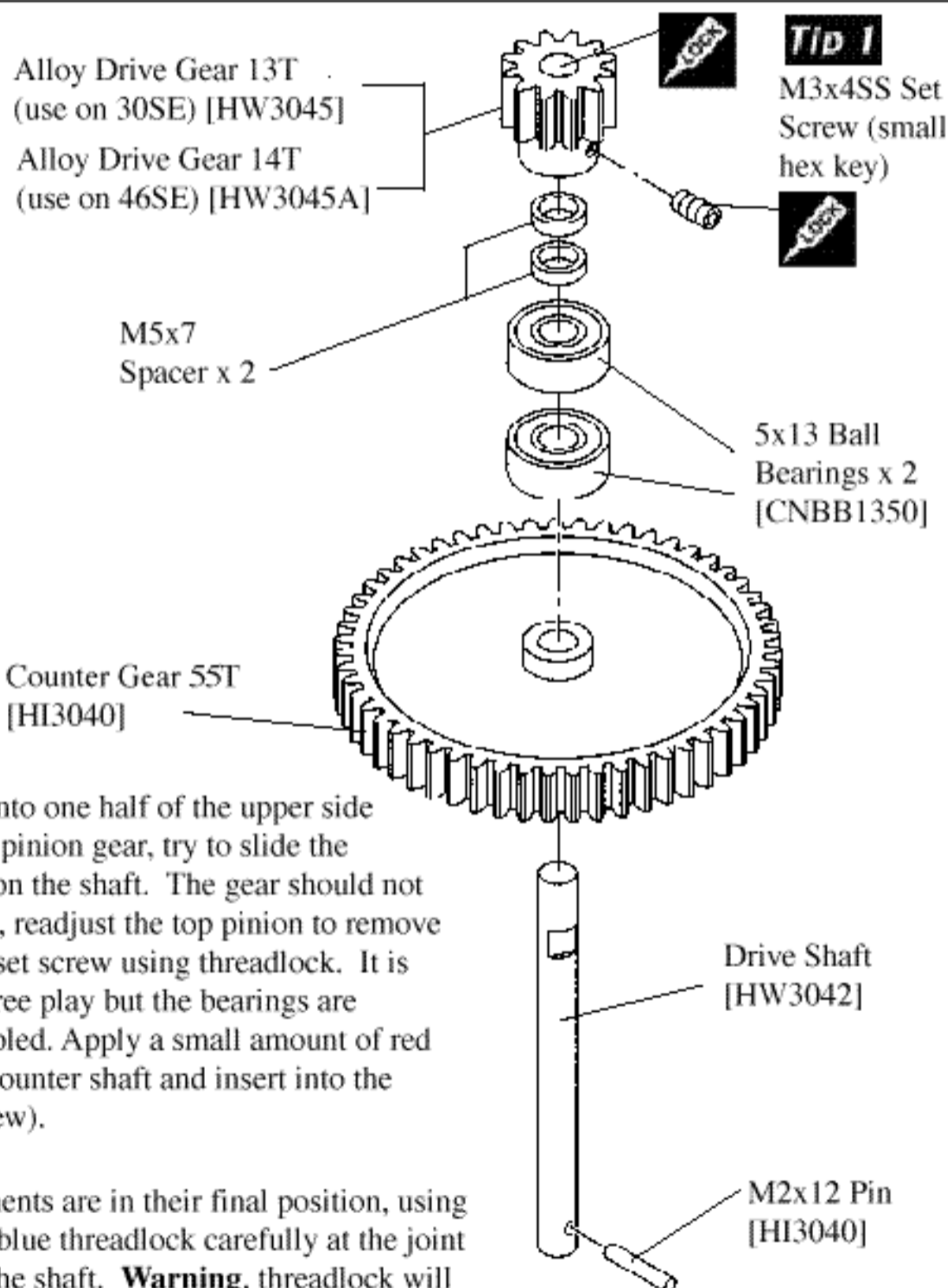

Step 12 Main Gear Assembly

The Main Gear is **pre-assembled with the Auto-Rotation Bearing installed**. From parts bag 2, the Main Shaft has a step in the end of the shaft that is inserted through the auto-rotation assembly. Insert the bottom end through the auto rotation gear assembly aligning the holes and secure the Main Shaft using one 3x16mm Socket Cap Screw and one 3mm Locknut.

Step 13 Slipper Assembly - 46SE only

The slipper drive unit will continue to turn the tail rotor blades in the event of an auto-rotation. Before installing the main shaft the Cir-Clip must be removed from the top of the main gear assembly, use Cir-Clip pliers that have special tips to spread the clip (very useful when changing the main gear). Slide the thin washer followed by the thick washer and grease the o-ring and set in place. Install two set screws (**Tip 1**) and slide against the o-ring, apply enough pressure that when the main shaft is turned the main gear rotates. Remove and apply threadlock to one set screw at a time.

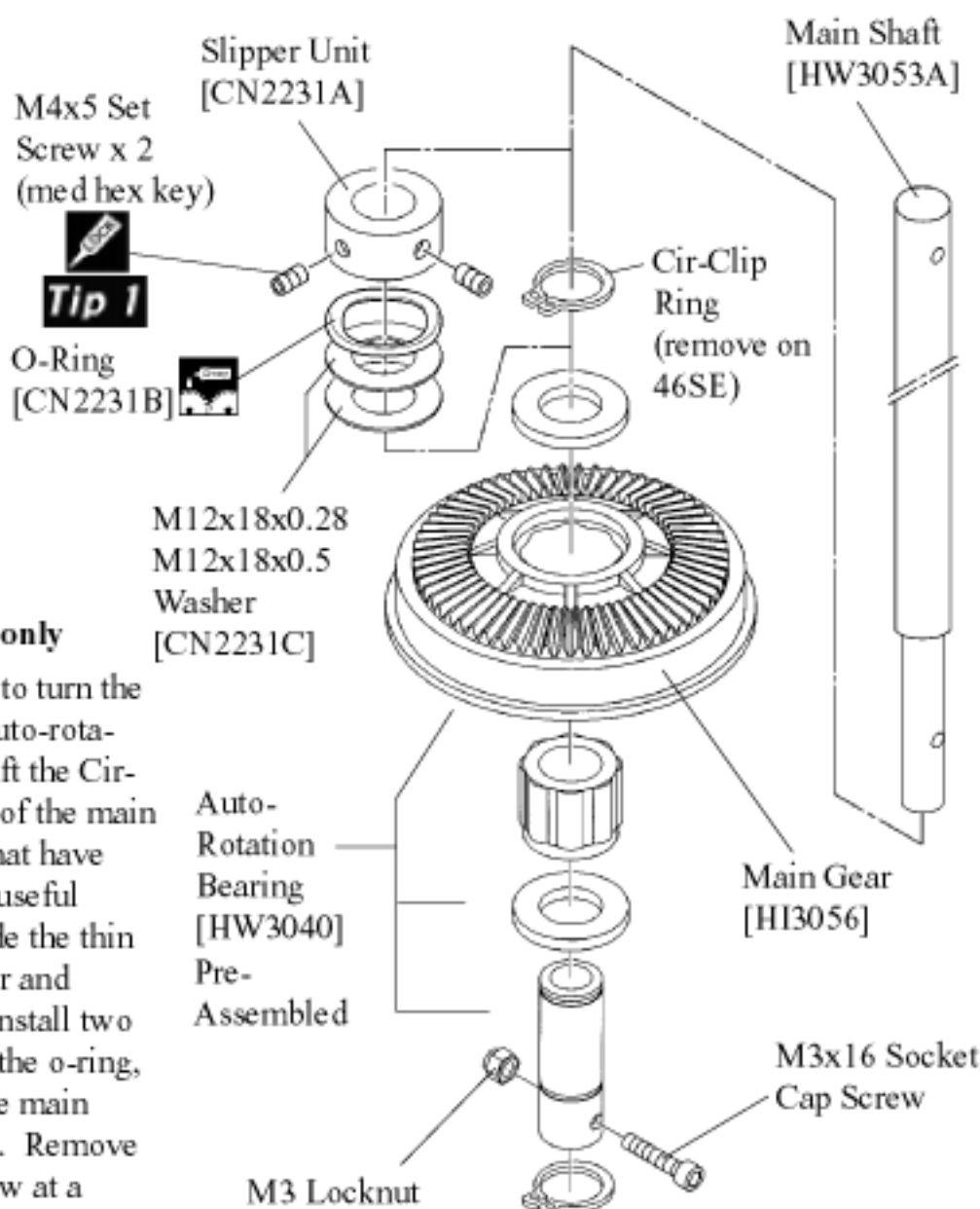

Step 14 Elevator Lever

From parts bag 2, insert the long threaded axle and one M3x7 ball bearing from each end of the bellcrank. Slide one short spacer over one 3x30mm Socket Cap screw and attach to the threaded axle (**do not use threadlock here!**), repeat for other side. The 2x16mm pin is assembled, just insure the elevator radius link moves freely against the Bellcrank. Thread one short black ball into the elevator arm.



CNQSC04
Optional machined ball bearing elevator arm w/ adjustable ball link.

Tip On the 46SE kit the bellcrank needs to be modified as shown to avoid binding at high cyclic while inverted. Use a file to cut a bevel as shown.

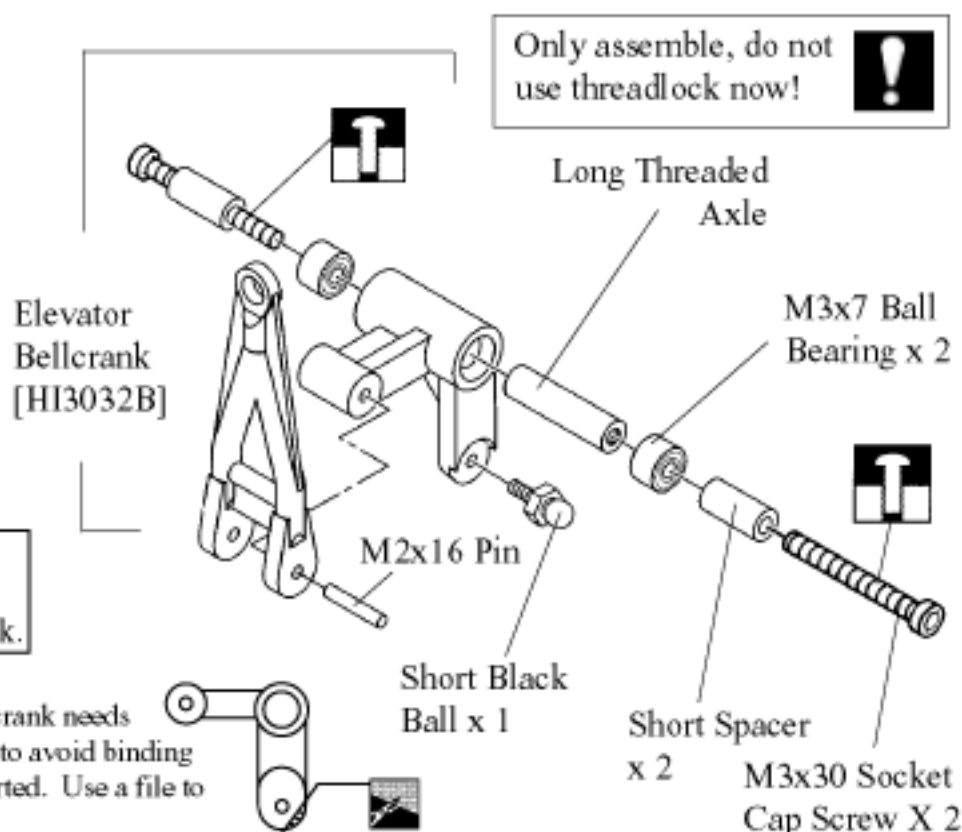

Step 15 Upper Side Frames

From parts bag 2, install two 4x5mm Set Screws (**Tip 1**) on the Mast Stopper then slide the mast stopper on the main shaft followed by one 14x19mm washer, only assemble at this time. Slide one M8x19 Ball Bearing on the bottom of the main shaft and one M10x19 Ball bearing from the top.

Attach the starter shaft assembly with four 3x12mm Self Tapping Screws¹ (**Tip3- observe the correct direction of the block assemblies**). Position the auto rotation gear assembly, the counter gear assembly and the tail transmission output shaft assembly at the locations on the diagram into the upper right side frame (**Make sure the bearings are fully seated in the recesses.**)

M3x12 Self Tapping
Screws x 4

Tail Transmission
Output Gear Assembly
from Step 11

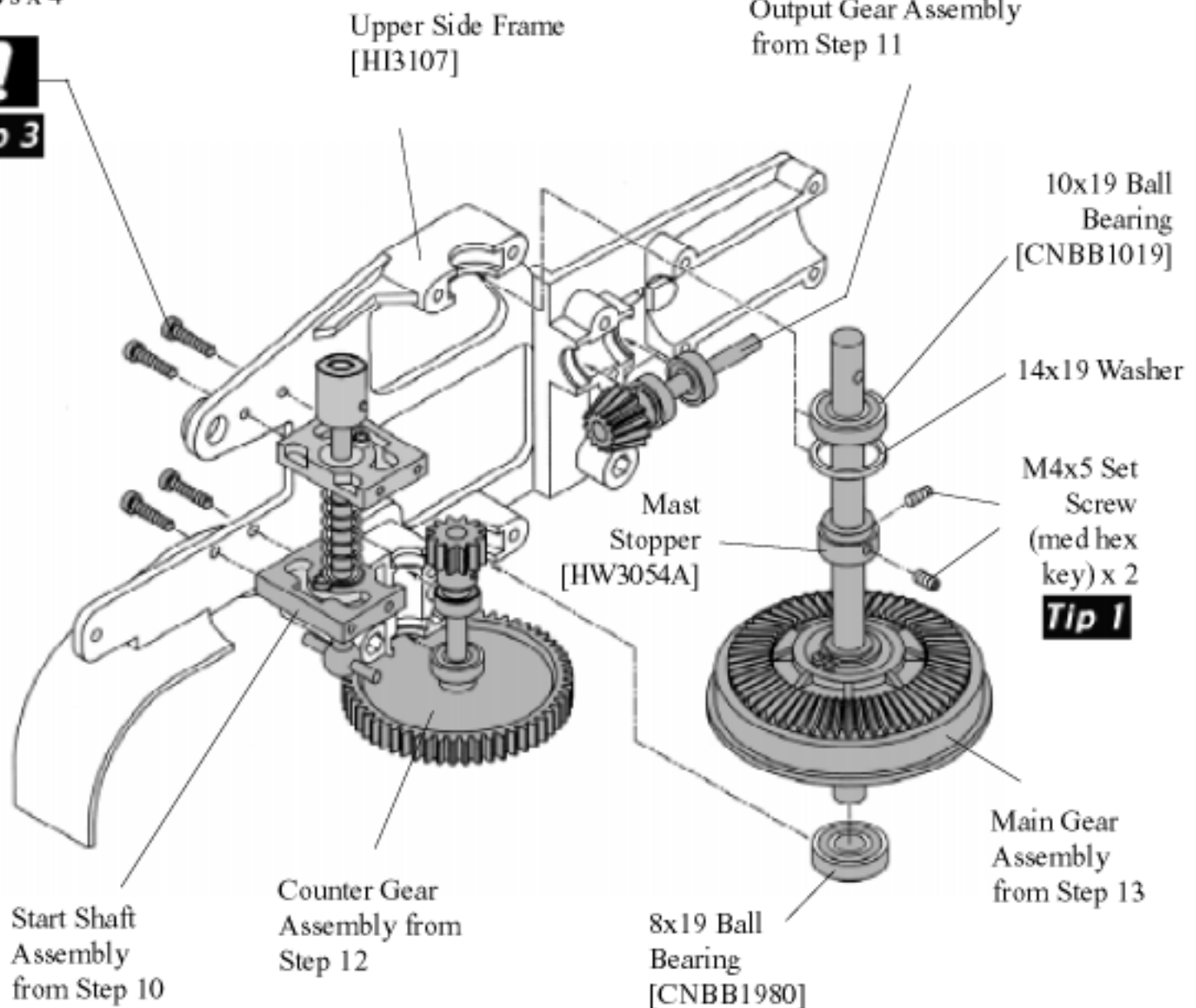

Note 1: Be careful when tightening the eight 3x12mm self tapping screws into the start shaft block assemblies as excessive force will strip out the plastic holes.

Step 16 Upper Frame Assembly

From parts bag 2, insert two long Hex Spacers at the specified locations in the diagram, note that the front hex spacer is installed into the forward-most hole. Install the upper left side frame, taking care that the bearings are aligned with the mating recesses and secure the frames with four 3x35mm Socket Cap Screws (**Tip1**) through the main shaft bearing block positions and four M3 locknuts. It is advised to position the elevator assembly between the side frames at this time to reduce the amount of disassembly later.

While pulling up on the main shaft (make sure the main gear rotates), push the mast stopper against the upper ball bearing, apply threadlock to the set screws and tighten in place. Attach the remaining four 3x12mm Self Tapping Screws(**Tip3**) to the starting shaft blocks.

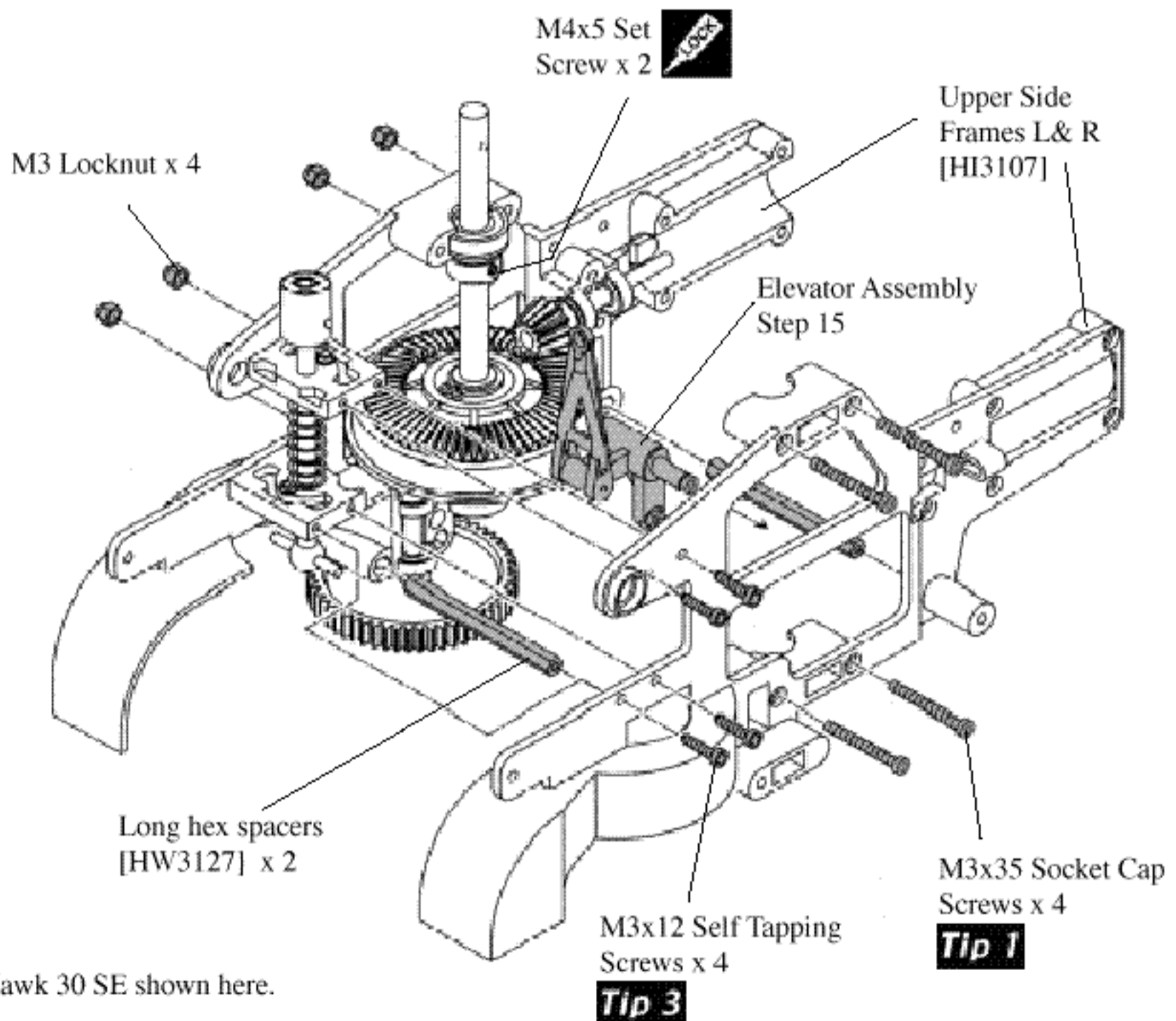

Note : The gear mesh between the main gear and the tail transmission output shaft should be a snug fit and will become smooth after a few flights, this is the normal wear in process.

Step 17 Collective and Aileron Levers

From parts bag 2, press in two M6x10 ball bearings into the front side frames for the collective axle. Attach the front Collective Arm Spacer (hex) and the Collective Axle (6mm dia) to the Right Collective arm (notice that the axle is attached at the middle hole) using two 3x10mm Socket Cap Screws using threadlock. Slide the assembly through the ball bearings in the upper frame sides from the right and attach the two Left Collective Arms with two 3x10mm Socket Cap Screws (*Tip1*) using threadlock (tighten the screws until the collective levers move freely with no side to side play.) Install one Short Ball on to the collective lever using threadlock.

Starting with the left Aileron Bellcrank press one 3x7mm Ball Bearing into one side followed by one 3x5mm spacer and the one more bearing from the opposite side (**the bellcrank is offset, make sure the "A" is facing inwards**). Install two short steel balls (*Tip2*). Starting on the left side, remove the 3x30mm Socket Cap Screw and short spacer from the **elevator bellcrank** (previously assembled in Step 15), slide the left aileron assembly onto the screw and slide one 3x5x0.5 washer before inserting through the left collective lever. Apply threadlock to the end of the screw threads now and slide the short spacer and tighten into the elevator bellcrank axle. Repeat for the other side.

Slide one Threaded Extension Rod through the upper position of the tail output bearing recess and secure two Short Hex Standoffs (one per side) using threadlock (*Tip2* - these are to attach the canopy).

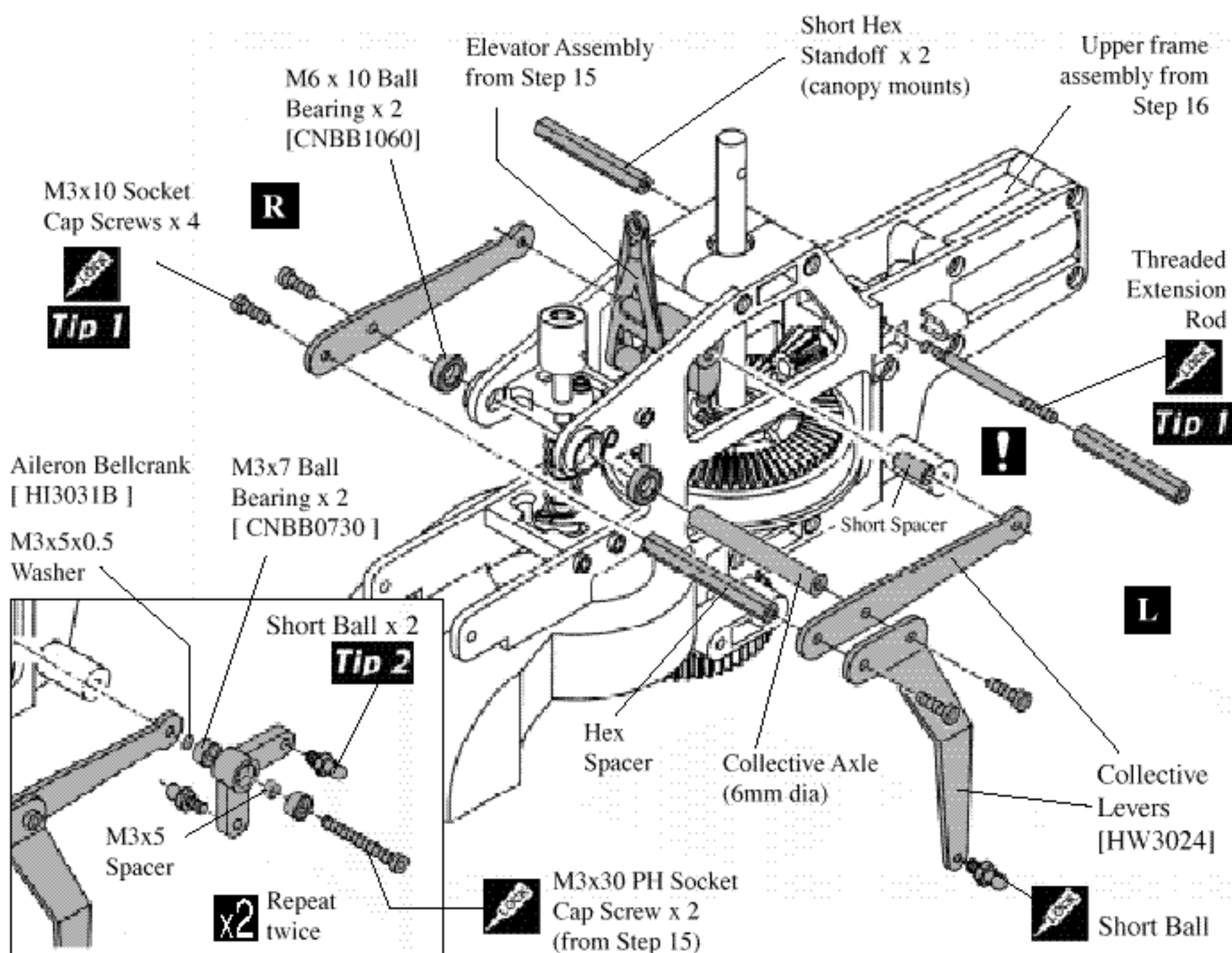

Step 18 Clutch, Fan & Engine Mounting

From parts bag 3, remove all parts from the engine crankshaft until you can see the front ball bearing, install the 9x14mm Flat washer (or washer provided by engine manufacturer), insert the Ball Bearings into the clutch bell assembly and place on the crankshaft. Clean the threads (**Tip 1**) on the crankshaft, engine nut and the clutch, carefully apply threadlock on the engine crankshaft threads nearest the bearing (be careful not to get threadlock into the ball bearings) and on the threads in the clutch. Thread the clutch until the crankshaft can be seen and insert the fan keying it to the clutch. Wrap a cloth over the fan (provides grip to the fan without breaking the fins) and tighten until the clutch stops, torque an additional 1/16 of a turn. Using a Piston Lock [CN2155 Optional Parts] makes this easier. Secure the fan by placing one 6.5x13mm Washer and apply a liberal amount of threadlock to secure the nut that came with the engine from the inside of the fan assembly using. Again only torque the nut 1/16th more.

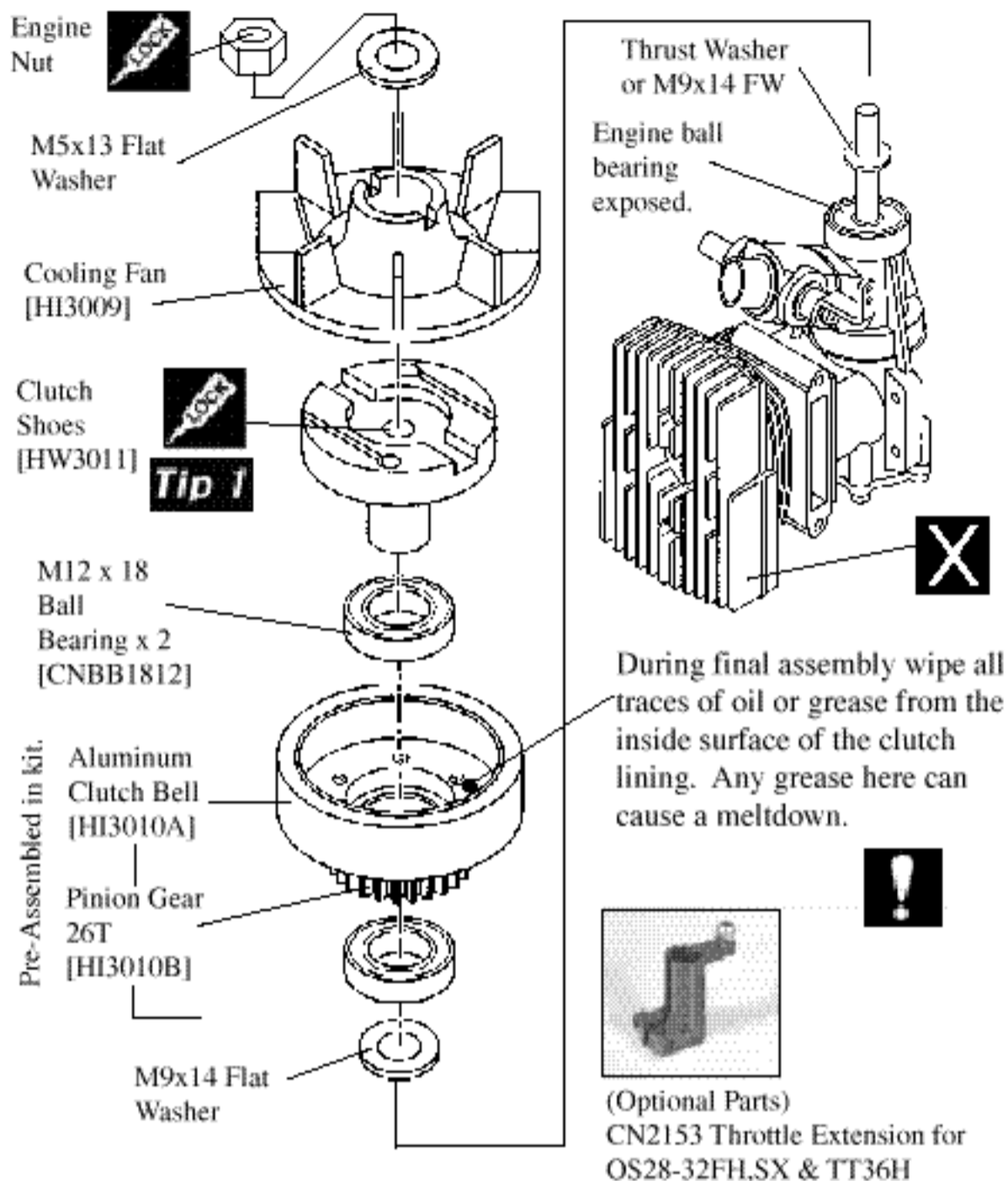

Step 19 Engine Mount & Throttle Lever

Secure the engine assembly on to the engine mount (46SE make sure the mount is installed with the holes closest to the bottom of the engine) using four 3x16mm Socket Cap Screws using threadlock. From bag 4, install the Throttle Extension by removing the arm supplied on the engine. The arm has to be repositioned to get equal throw, both open and closed from 50%.

Throttle arm on Carburetor

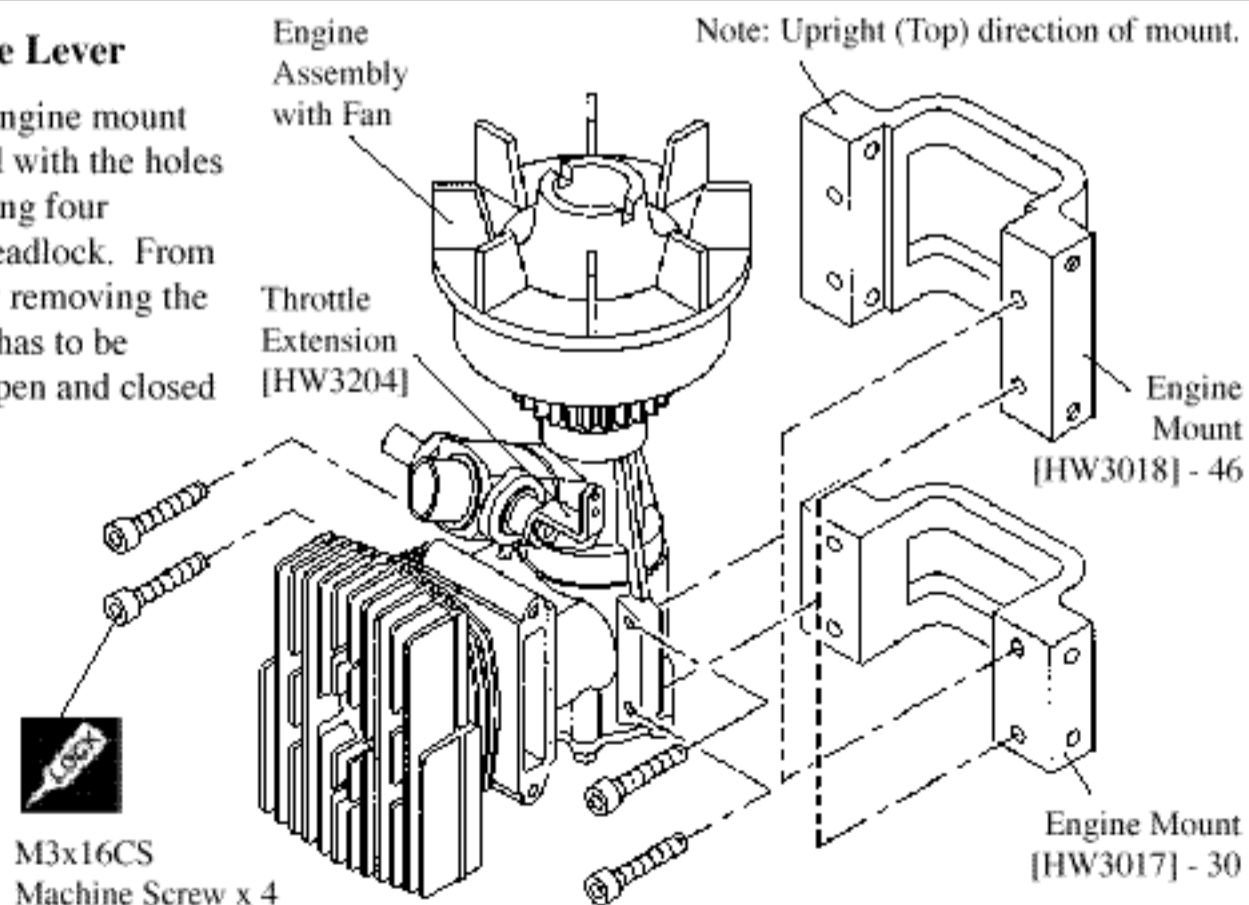
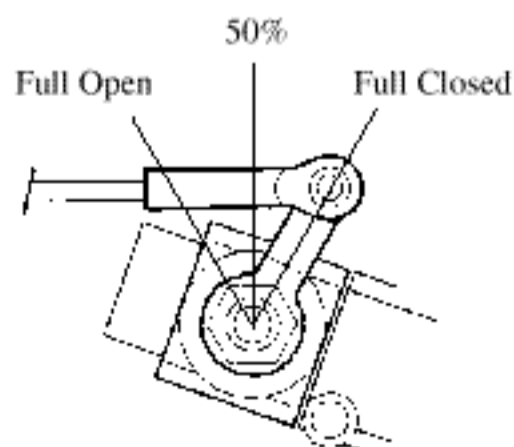

Step 20 Fuel Tank Assembly

From parts bag 3, insert the two pieces of aluminum tubing through the large cap, rubber stopper and small cap, bend the long aluminum tube upwards and attach the short piece of fuel line and clunk to the short straight piece of tubing. Test fit the assembly into the Fuel Tank and make sure that the clunk reaches the end but moves freely and the vent tube is near the top of the tank but does not touch. Finally tighten the long self tapping screw to seal the tank. Install the included tie wrap around the outside of the rubber cap.

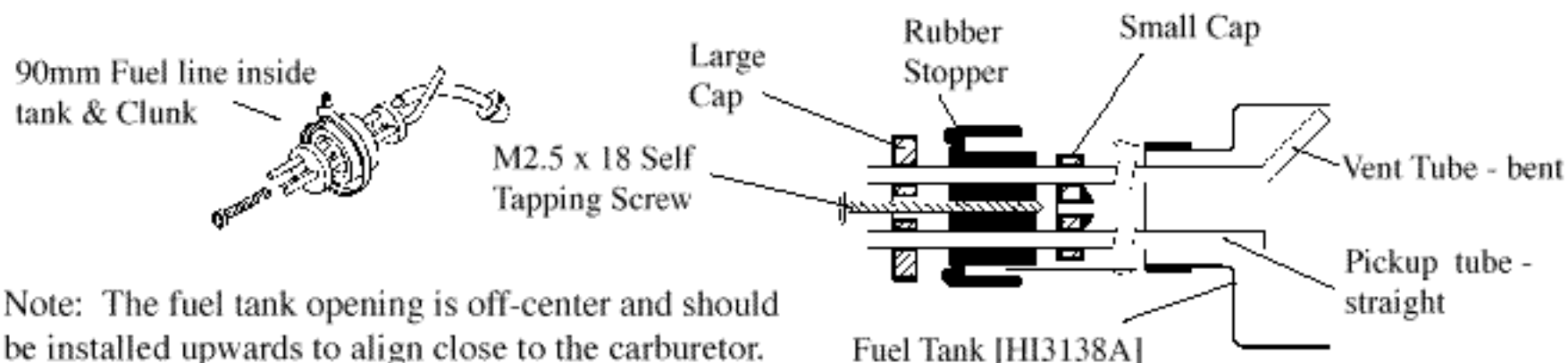

Note: The fuel tank opening is off-center and should be installed upwards to align close to the carburetor.

Step 21 Lower Frame Assembly

Attach the right lower frame (R) to the upper frame assembly with two 3x12mm Socket Cap Screws (**Tip 1**) using threadlock. Slide the cooling Fan Shroud over the engine head and position the engine assembly into the upper frames while attaching the two M3x16 Socket Cap Screws through the R side frame (leave these loose for now). Skip to step 26 and install the muffler at this time as it is difficult later to get access to the muffler screws. Slide the fuel tank assembly through the frame and attach the left lower side frame (L) to the upper side frames using two M3x16 Socket Cap Screws using threadlock. Attach two M3x12 Socket Cap Screws and two M3x11 Flat Washers to the engine mount, loosely for now.

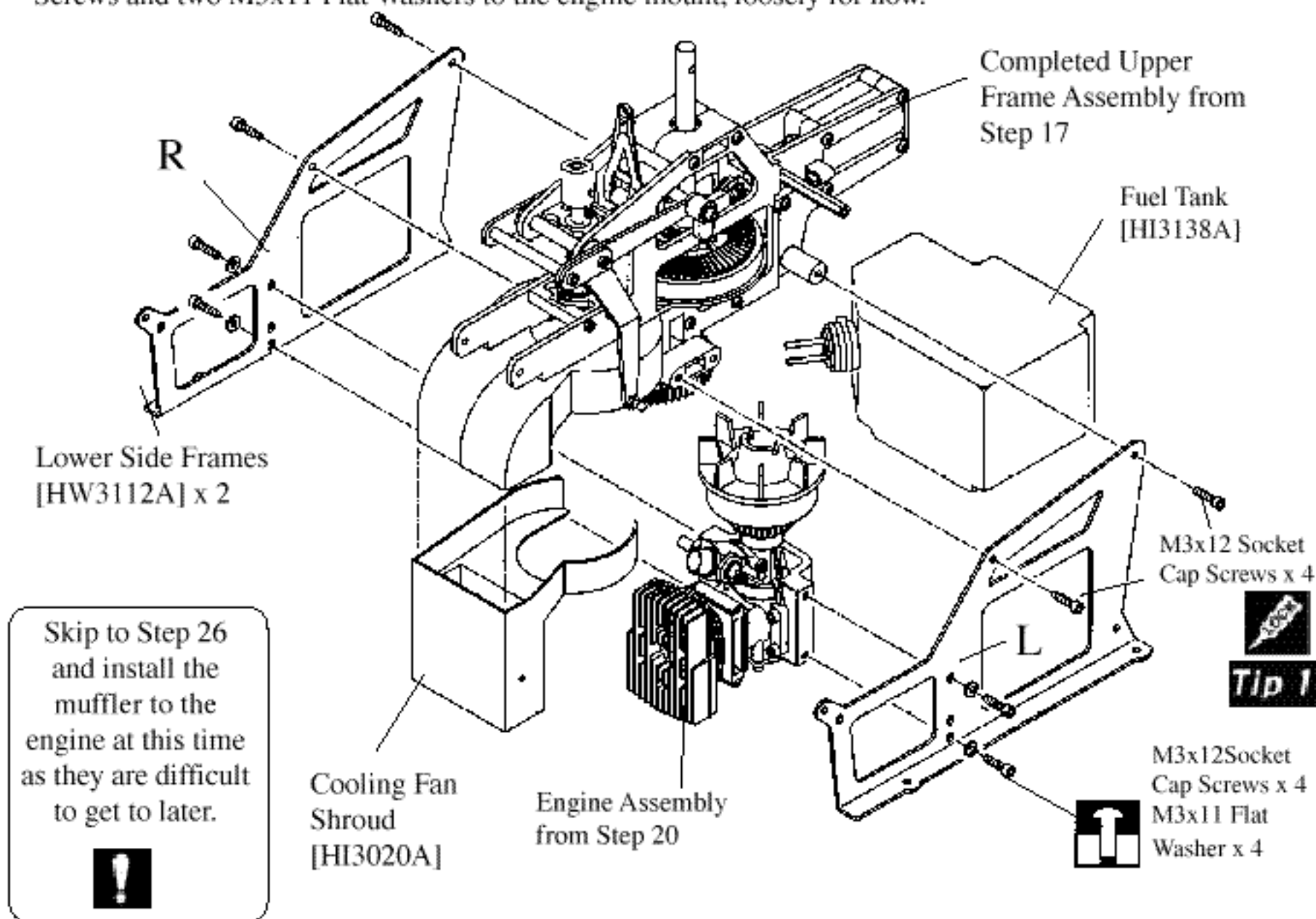

Skip to Step 26 and install the muffler to the engine at this time as they are difficult to get to later.



Step 22 Servo Frame Assembly

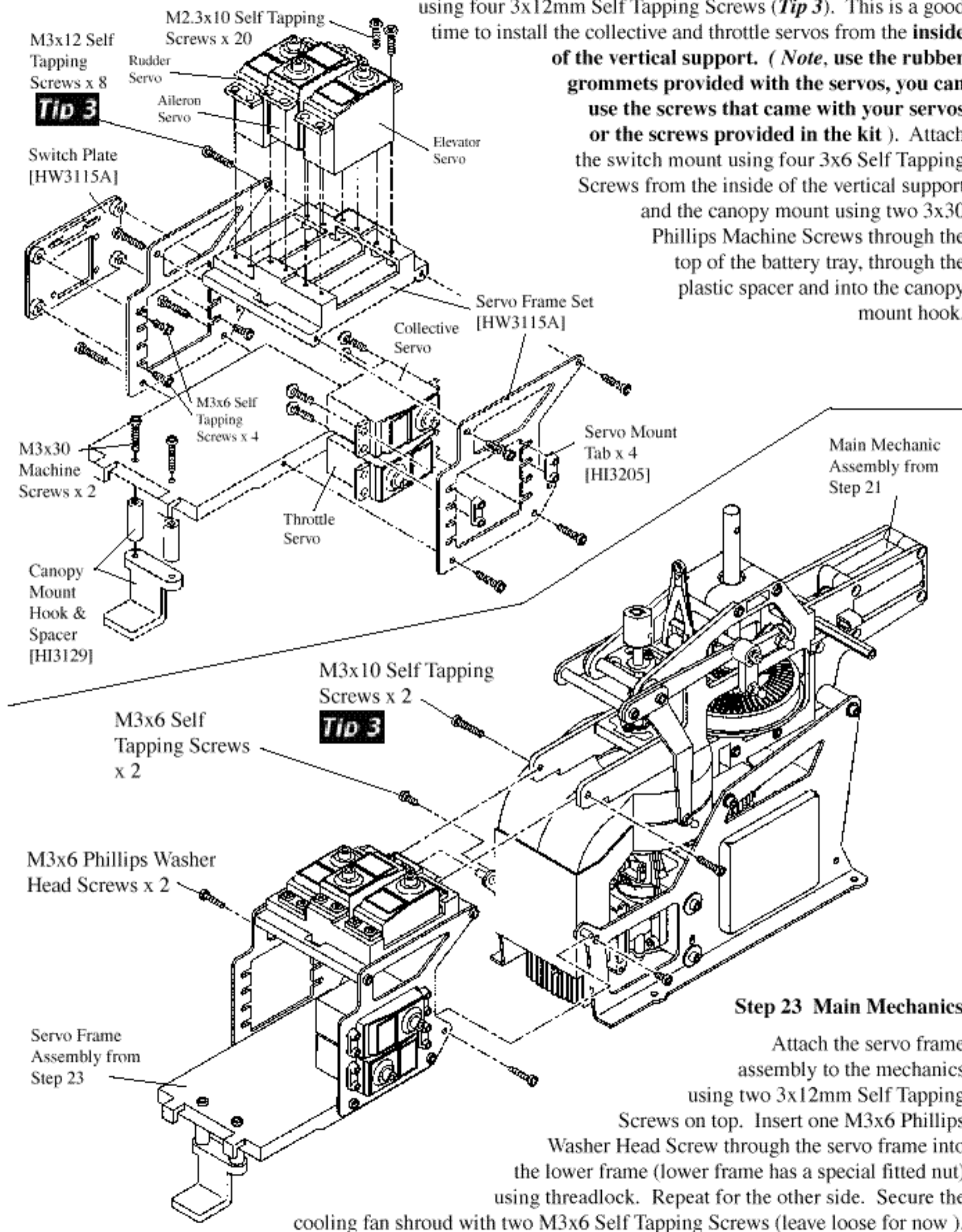

From parts bag 5, assemble the servo tray using four 3x12mm Self Tapping Screws (**Tip 3**). This is a good time to install the collective and throttle servos from the **inside of the vertical support**. (*Note, use the rubber grommets provided with the servos, you can use the screws that came with your servos or the screws provided in the kit*). Attach the switch mount using four 3x6 Self Tapping Screws from the inside of the vertical support and the canopy mount using two 3x30 Phillips Machine Screws through the top of the battery tray, through the plastic spacer and into the canopy mount hook.

Step 23 Main Mechanics

Attach the servo frame assembly to the mechanics using two 3x12mm Self Tapping Screws on top. Insert one M3x6 Phillips Washer Head Screw through the servo frame into the lower frame (lower frame has a special fitted nut) using threadlock. Repeat for the other side. Secure the cooling fan shroud with two M3x6 Self Tapping Screws (leave loose for now).

Step 24 Final Rotor Head Assembly

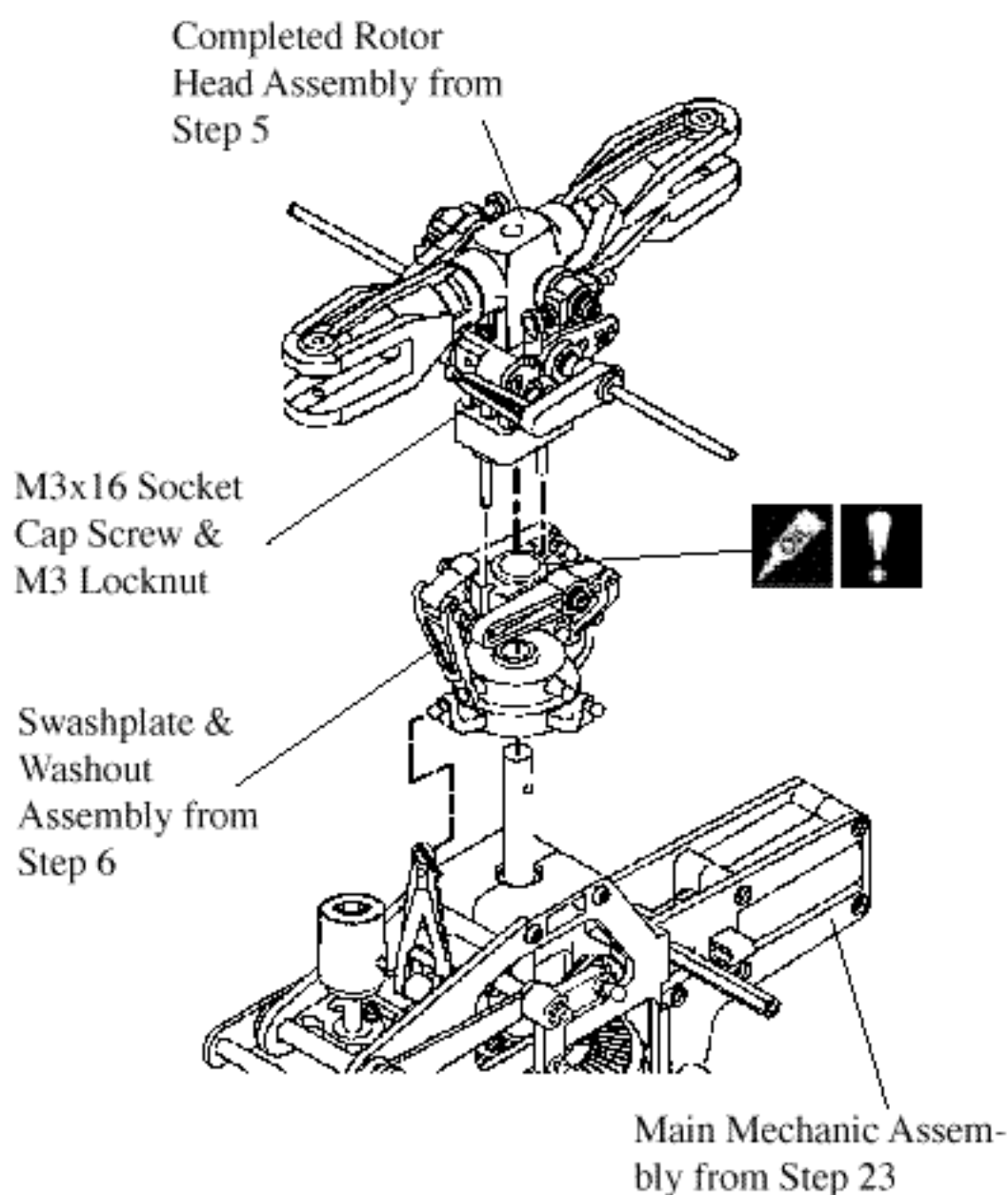

Slide the washout assembly from Step 6 onto the main shaft and snap the elevator lever arm onto one of the single front ball on the swashplate. Slide the completed rotor head assembly from Step 5 onto the shaft and align the hole in the head block with the hole in the top of the main shaft and insert one 3x16mm Socket Cap Screw and 3mm locknut (from Bag 2) to secure the two. (**Note: Make sure the pins in the rotor head block are aligned and inserted into the holes in the washout unit.**) Apply some oil sparingly to the washout hub assembly to insure they slide smoothly.

Following assembly, move the collective lever fore and aft to the endpoints. The swashplate and washout unit should be very smooth throughout the movement range. If not, inspect the fit of the washout guide to the pins in the rotor head, these pins can be bent slightly if binding. Also check the collective axle, the screws here may be too tight. Lastly the fit of the ball links sometimes can cause binding. These few points are the most common which will cause servo strain leading to premature wear and will appear as a jump in altitude when flying the helicopter.

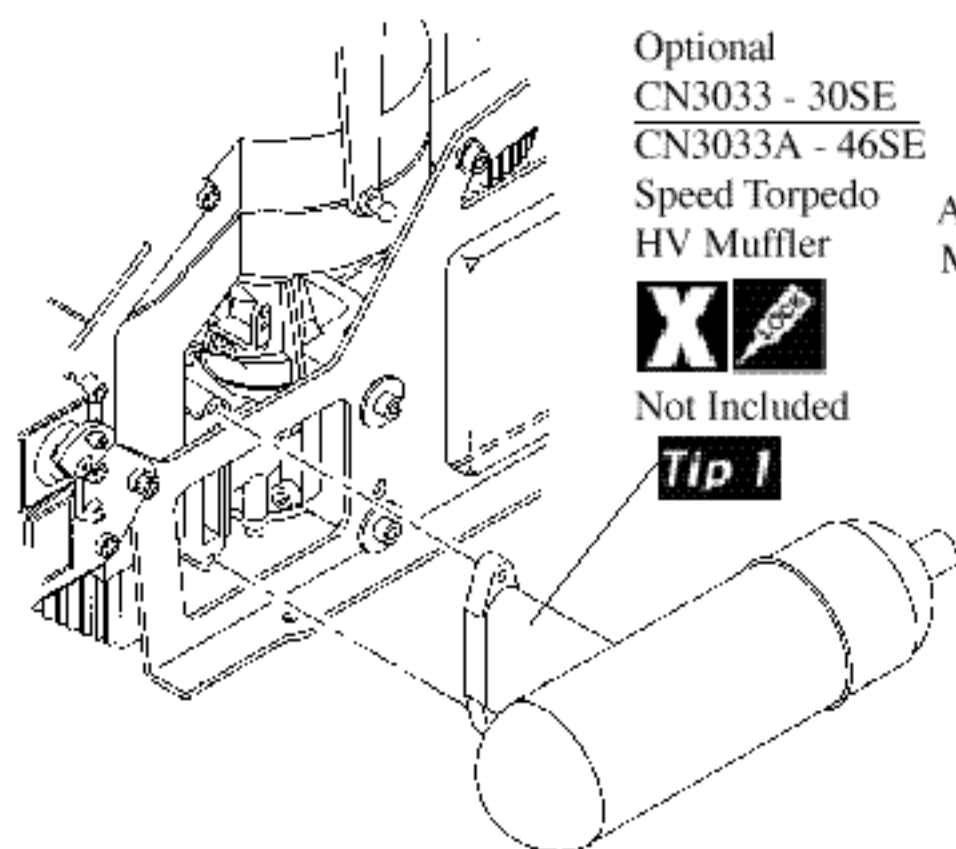

Step 25 Attaching Muffler

Attach the muffler to the engine with the screws provided with the muffler (**Tip 1**) using threadlock. Attach the pressure tap to the top of the muffler and the M4x6 Phillips Machine screw to the bottom hole in the muffler, remember to use threadlock on these parts.

For a good seal between the muffler and the exhaust port, use a gasket made from thin aluminum, brass or use high temperature RTV engine sealant found in an automotive supply store. To properly seal the fit, after running the engine for several minutes on the first run, shut down the engine and tighten the bolts again, with the hot engine you will gain 1/4 turn on the bolts which will seal the muffler in place.

Tip

Step 26 Landing Gear Assembly

From parts bag 6, assemble the landing gear by attaching the Aluminum Skids through the Struts, securing them with four 3x5mm Set Screws. Set the distance from the rear of the skid to the strut at 35mm. Attach the landing gear to the main mechanics using four 3x16mm Phillips Machine Screws inserted from the bottom of the struts and through the M3x9 plastic spacers into the lower side frames and secure with four M3 locknuts.

Tip When routing the antenna wire from your receiver, insert the wire through the plastic guide tube and attach to the vertical fin using an elastic tied between the end of the antenna wire and the fin.

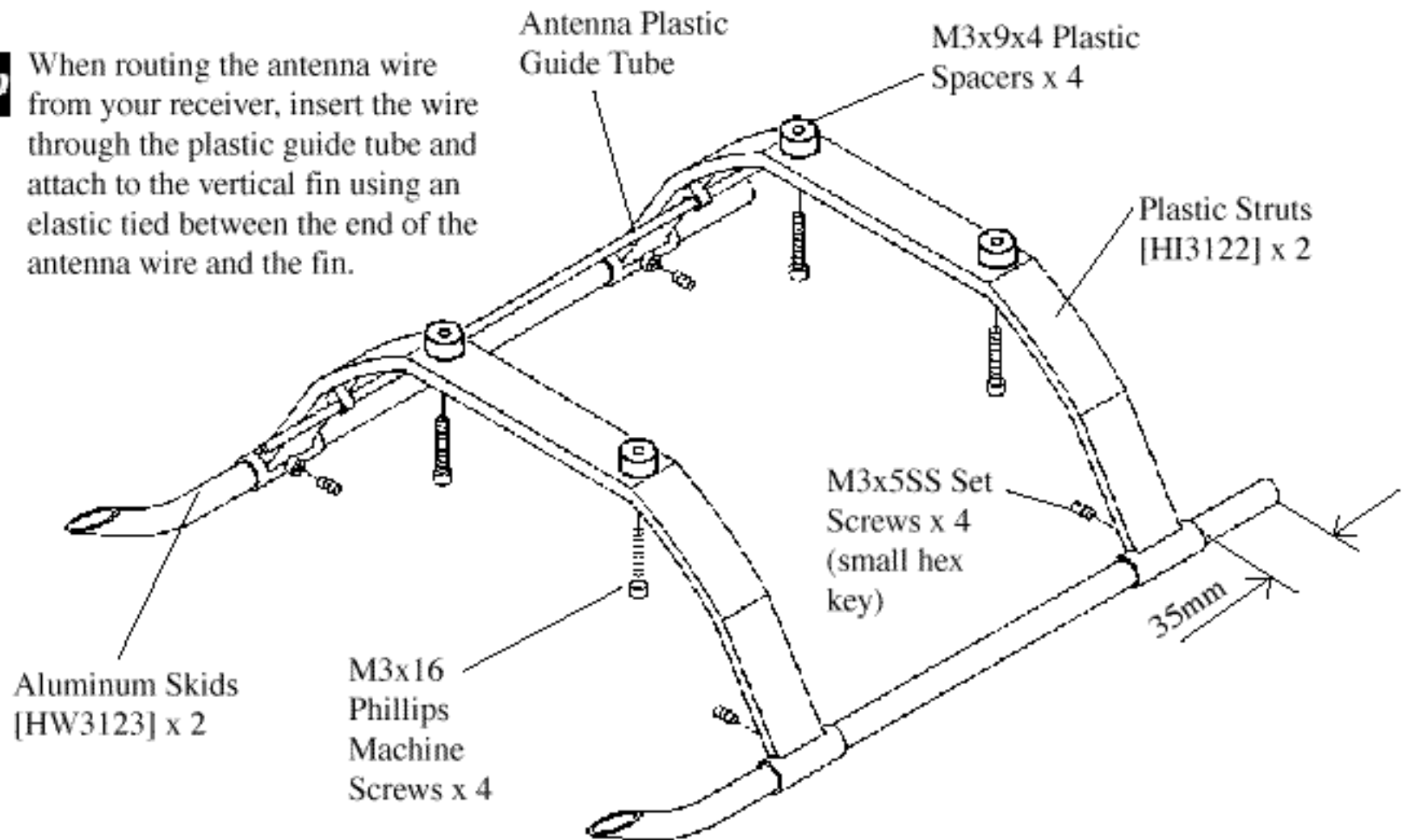

Step 27 Tail Output Shaft Assembly

From parts bag 7, notice that the Tail Rotor Drive Shaft has 2 holes, one through the shaft and one drilled partially into the shaft. Slide the small Bevel Gear with the teeth facing the shaft from the end with the through hole and position the gear aligning the holes. Press the 2x12mm Pin through and secure with one 3x4mm Set Screw (*Tip 1*) using threadlock. Slide the Spacer Tube onto the shaft and position against the gear.

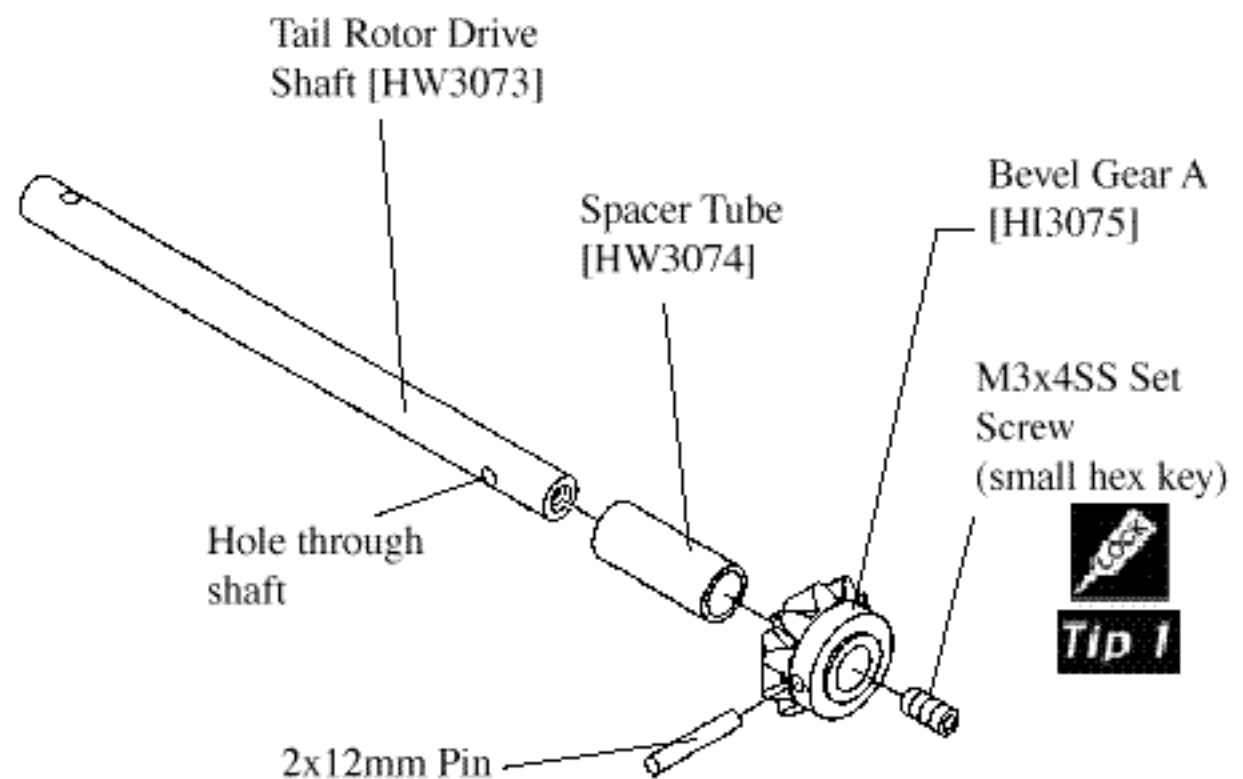

Step 28 Tail Pitch Plate Assembly

From parts bag 7, the Tail Pitch Plate and Tail Pitch Ball Links are pre-assembled. (**Note:** apply some JB weld to the outside of the lock ring to avoid the assembly loosening.) Put this assembly aside for now.

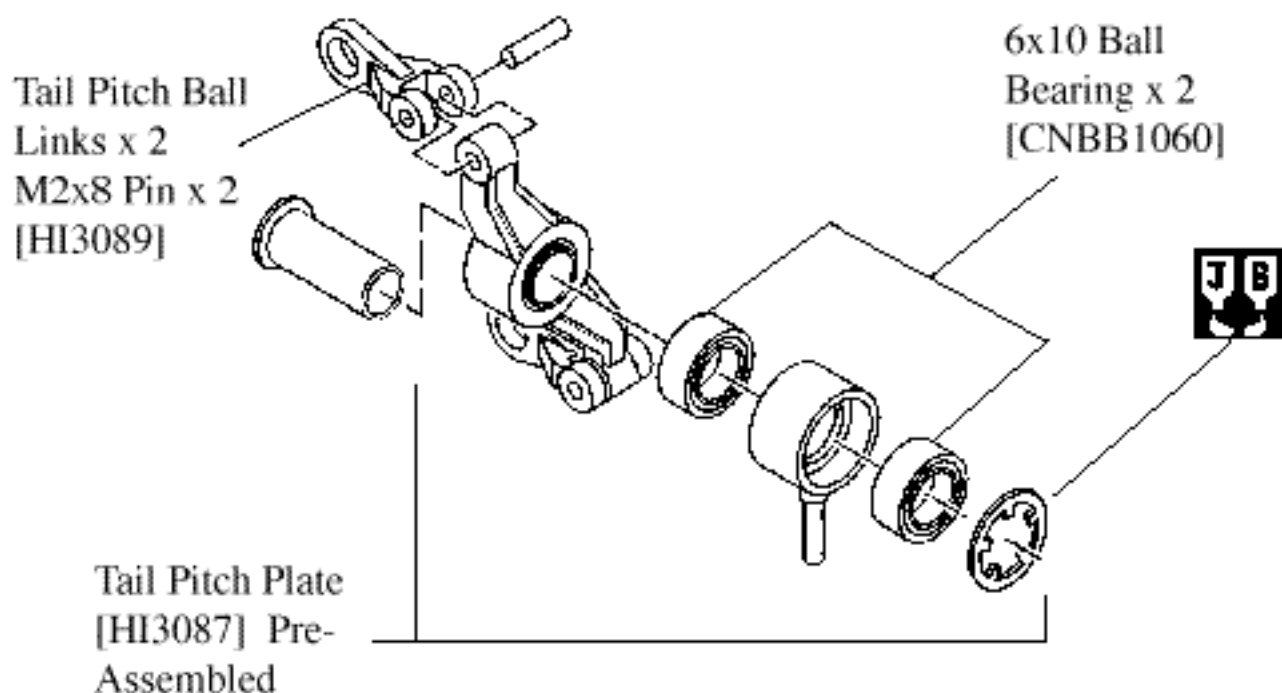

Step 29 Tail Input Shaft Assembly

From parts bag 7, assemble the Tail Rotor Output Shaft by sliding two Ball Bearings on to the shaft followed by the large Bevel Gear. Align the holes on the gear with the shaft and press in one 2x12mm Pin and secure with one 3x4mm Set Screw (**Tip 1**) using threadlock.

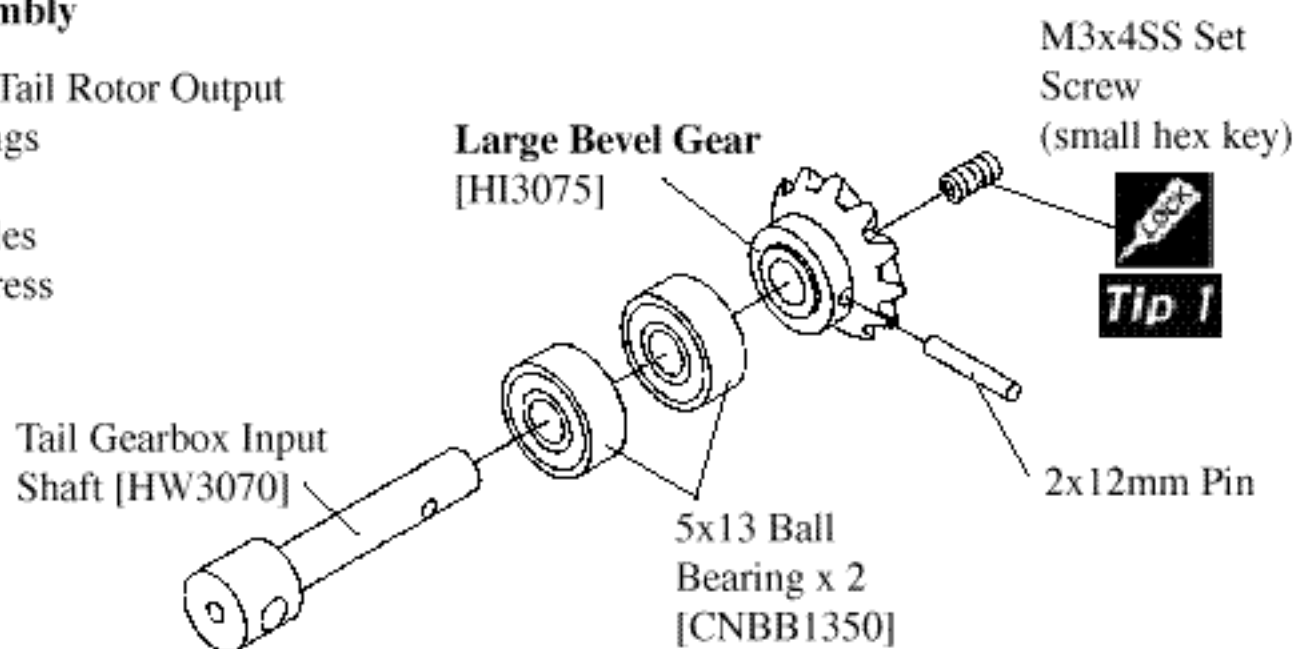

Step 30 Tail Gearbox Assembly

Slide two Ball Bearings on each side of the Tail Rotor Drive Shaft assembly and insert through the right side of the Tail Rotor Gearbox Housing, make sure the bearing is fully seated into the recess. Slide the tail rotor pitch plate assembly on the shaft.

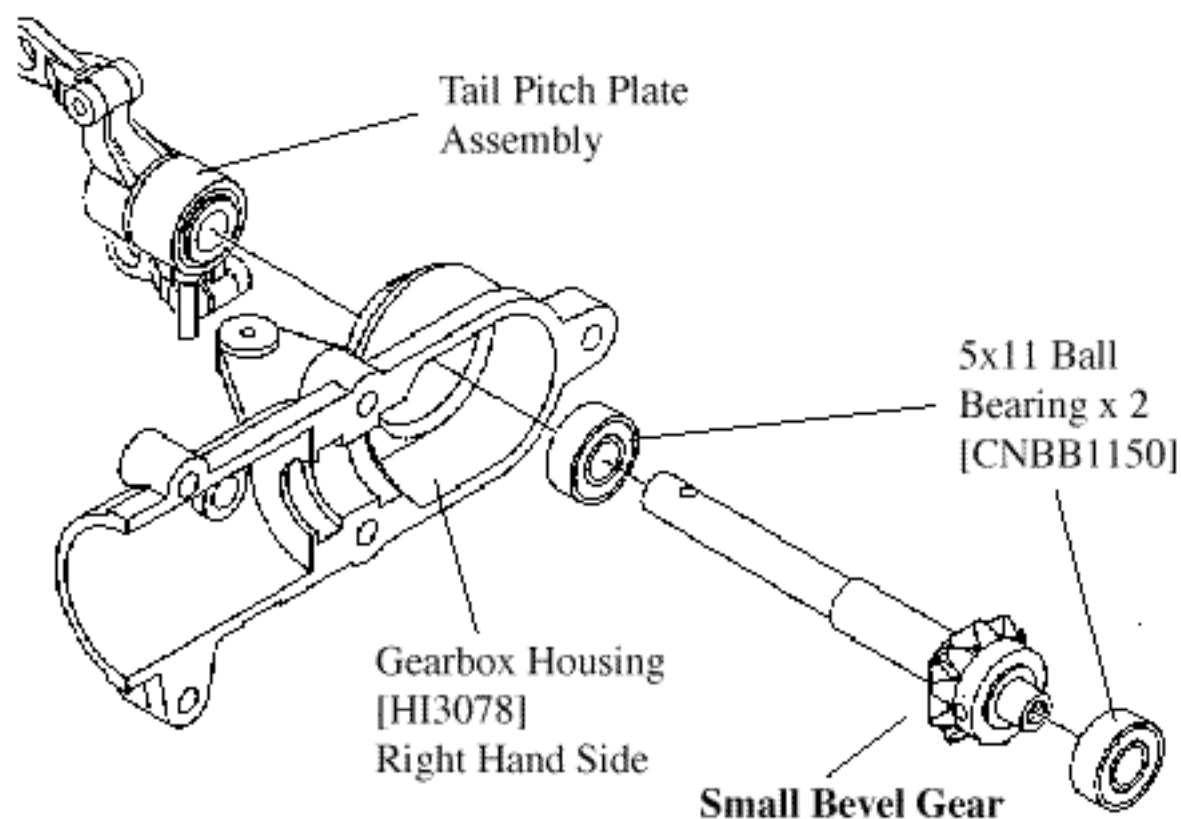

Step 31 Tail Rotor Grip Assembly

From parts bag 7, install the Tail Rotor Hub on to the tail rotor drive shaft, (**position the hub so the hole is aligned over the hole in the shaft**) and secure with one 3x4mm Set Screw (**Tip 1**) using threadlock. The hub is tapped for two holes, use one only.

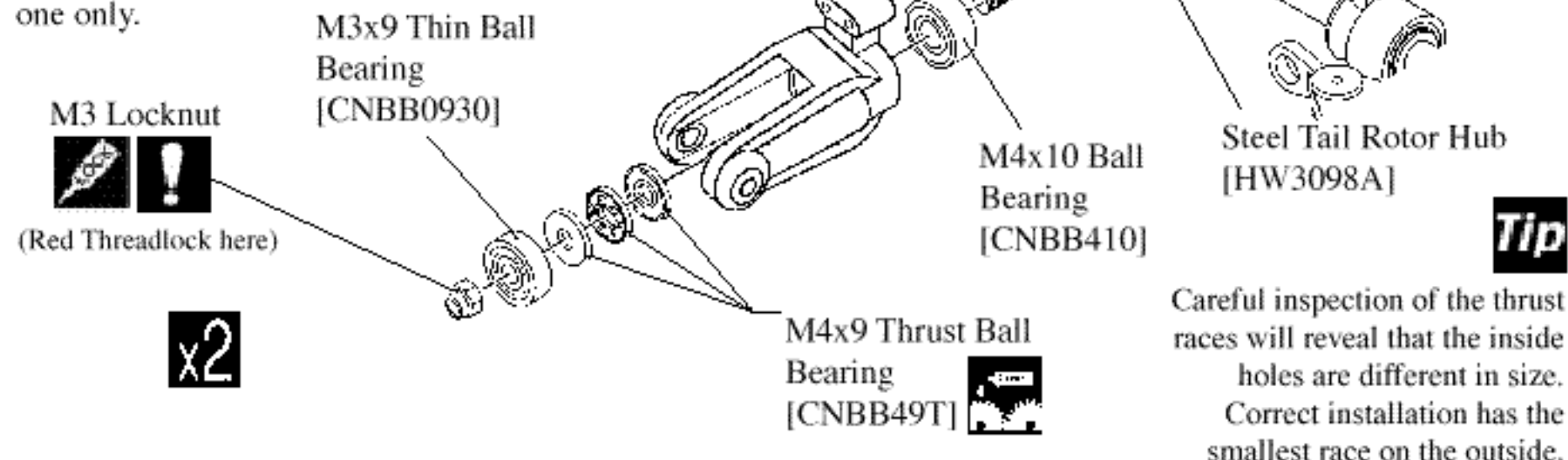

Install one short steel ball into the upper right hole in the tail rotor grip (**Tip 2**). Insert one M4x10 Ball Bearing into the blade grip on the ball side (make sure the bearing is fully seated flush into the grip). Slide the grip onto the tail hub and slide one M4x9 Thrust Ball Bearing (**install the first steel washer (larger inside diameter) followed by the ball race, remember to grease the ball race, followed by the second steel washer (smaller inside diameter)** followed by one M3x9 Thin Ball Bearing. Important, apply red threadlock to the threads in the M3 locknut (**to avoid getting threadlock into the bearings**) before threading onto the hub. Tighten the locknut slowly until there is no end play and the grip rotates smoothly.

Step 32 Tail Blades and Final Assembly

Snap the ball on the tail rotor grip into the adjoining pitch slider link on both sides. Install the Tail Rotor Blades shimmed with 3x10mm plastic washers on both sides using two 3x20mm Socket Cap Screws and M3 locknuts. Note the direction of the blades on the diagram, the leading straight edge of the blade should be on the same side as the ball on the blade grip. To tension the blade bolt, start loose and tighten until the blade holds horizontal but pivots freely when moved.

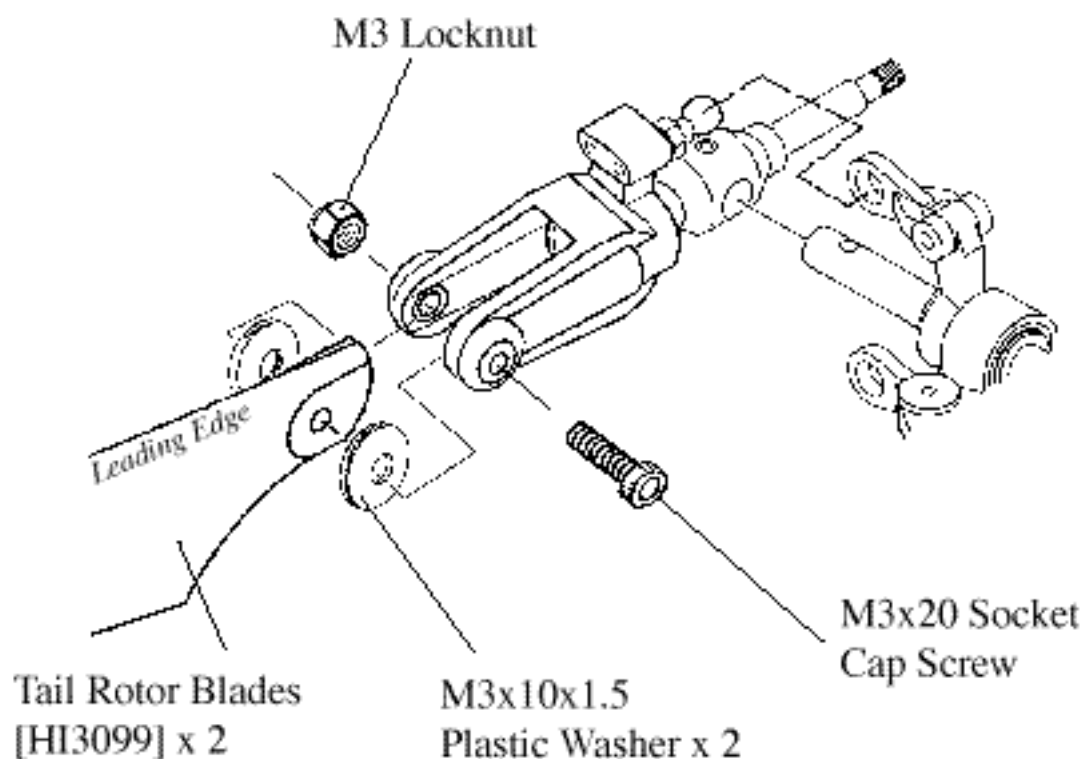

Tip After flying the model, if a vibration is noticed on the horizontal fin, you can remove the complete tail rotor assembly with the hub and further balance it using a High Point balancer. Careful sanding of the rotor blades is all that is needed.

Step 33 Tail Drive Shaft & Pushrod Guides

From Bag 7, insert three tail drive shaft Guides on to the Brass Tail Drive Housing, found in the bottom of the box (**Note that one guide has a larger center hole than the others, slide this one to the center of the brass tube**), add the remaining two onto the ends. Glue the guides into position using Zap Ca on the brass tube. Insert the rod guide assembly into the tailboom from the end with the 2 holes and position the assembly centered in the tailboom (**gentle tapping with a wooden dowel will ease the insertion of the guides**).

Slide the three tail pushrod guides onto the tailboom engaging tail pushrod. Thread the pushrod connector onto the long pushrod, the short pushrod will be attached in Step 38.

Tail Pitch Control Rod Set [HW3064C] - 30SE

Tail Pitch Control Rod Set [HW3064D] - 46SE

Tail Boom [HW3062] - 30SE

Tail Boom [HW3062A] - 46SE

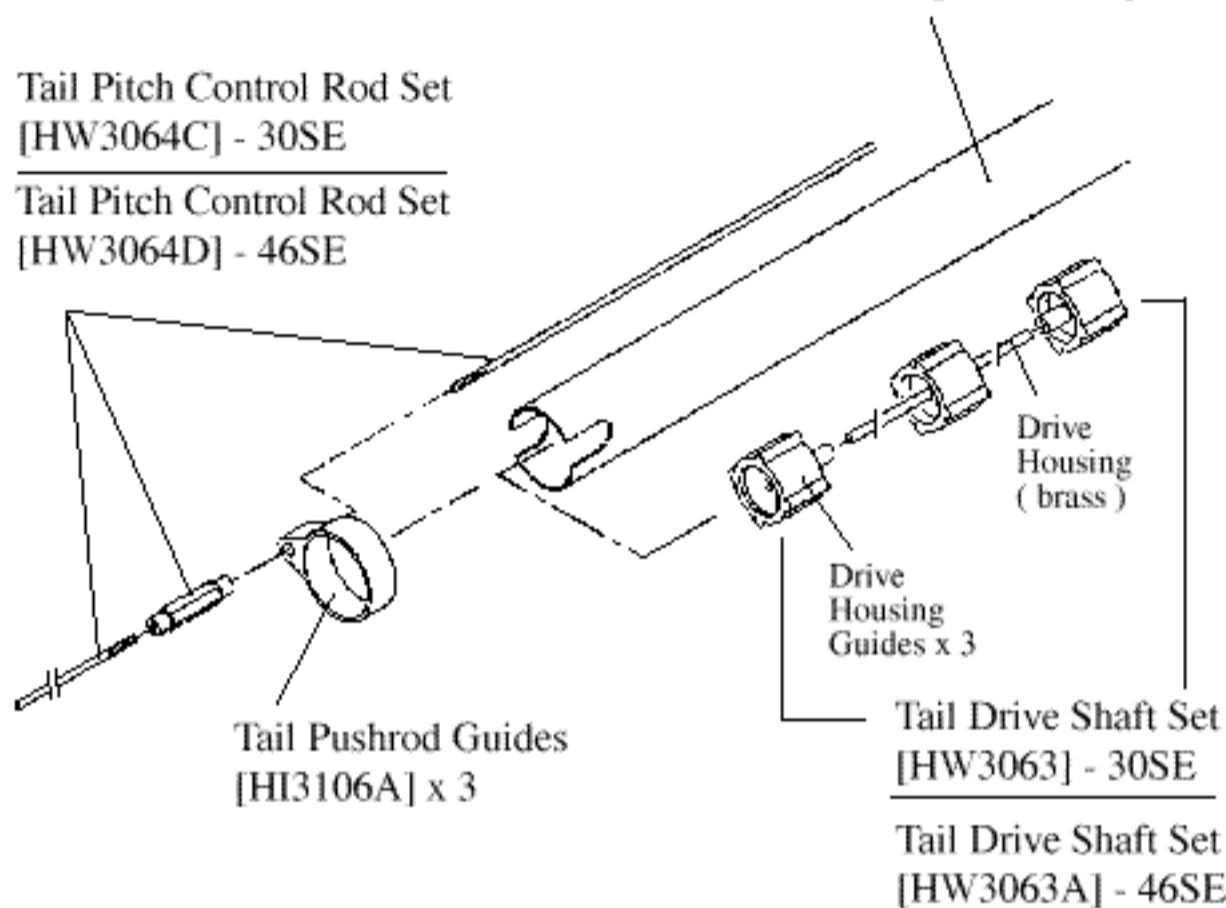

Make sure the brass tubing is glued to the internal guides for the tail boom. Also, after radio set up is complete glue the pushrod guides using a single drop of Zap Ca. One drop will stop the pushrod from binding and still be able to remove them later.

Step 34 Tail Drive Shaft

The Tail Drive Shaft has one end flattened to engage into the main mechanics the other end needs to have a flat spot 20mm long filed on the round end of the shaft for the two 4x4mm Set Screws in the tail rotor input shaft. Thoroughly grease the tail drive shaft (**Tip 1**) and insert the newly filed end into the tailboom end with the slots into the drive shaft housing assembly (**ensure the end with the new flat spot exits the tailboom end with the round holes**) and degrease both ends of the shaft.

Put a flat spot on the the round end of the Tail Drive Shaft.

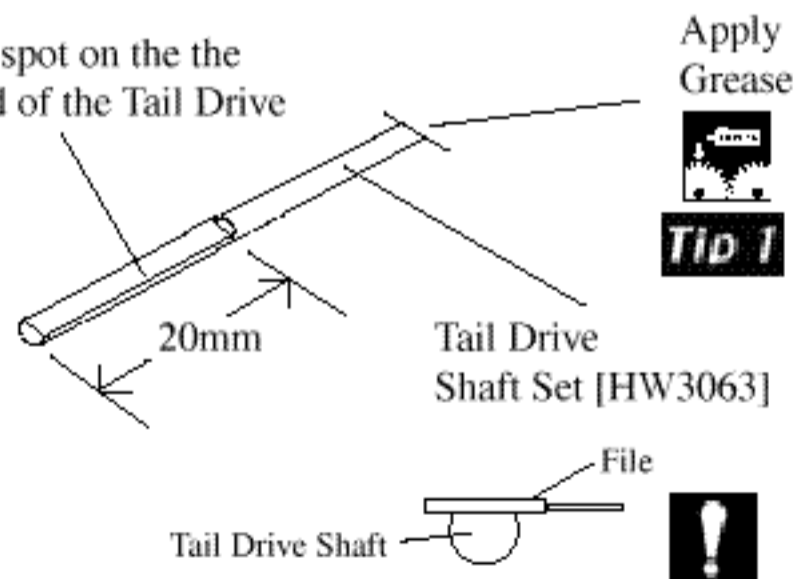

Tip

A flat file is the ideal tool for the job, alternately careful use of a Dremel Moto Tool will work. It is important that the flat be at least 1/4 of the diameter but no more than 1/3 to avoid weakening the material.

Step 35 Tail Gearbox Assembly

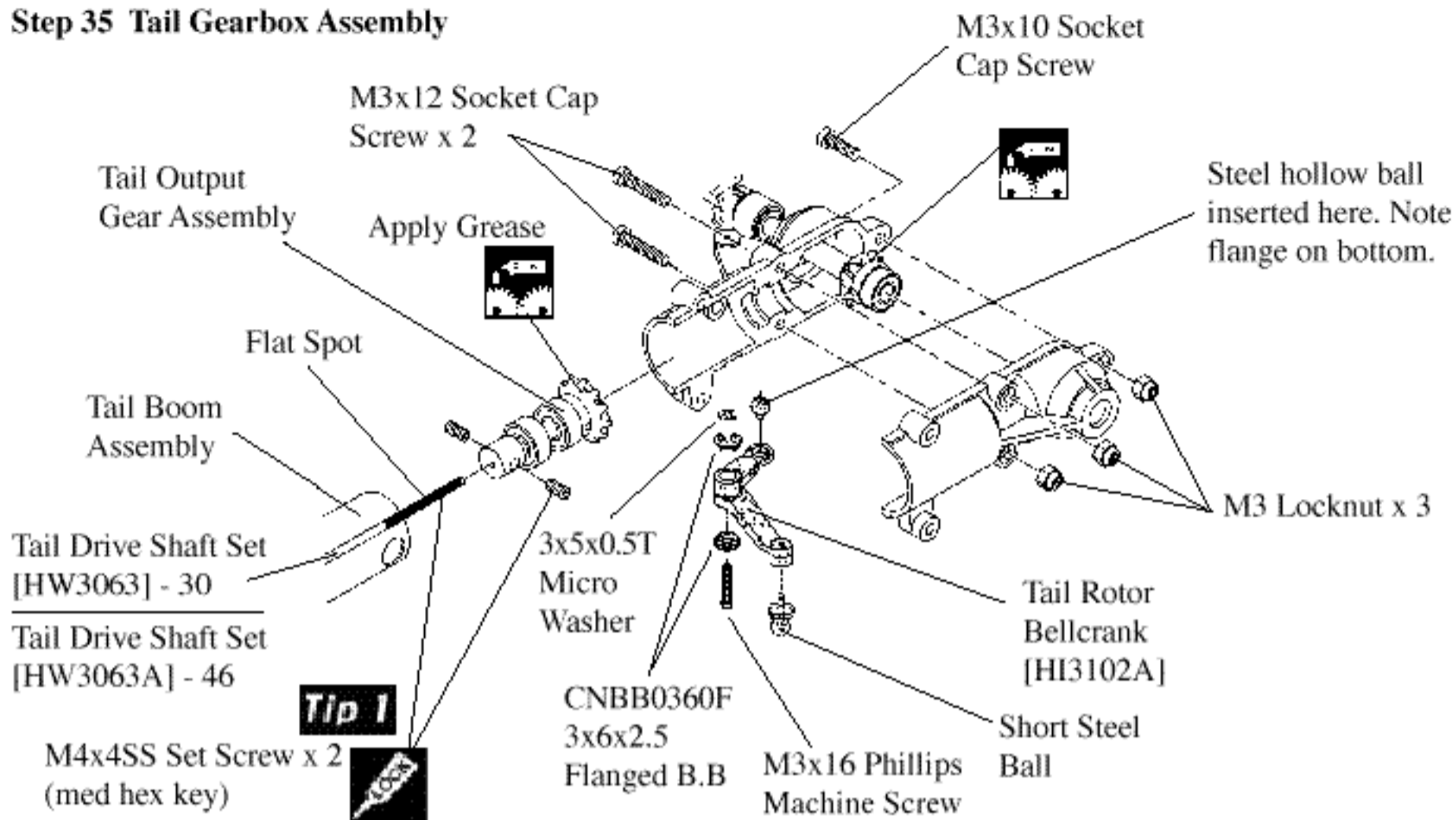

Attach the tail output gear assembly on to the drive shaft with two 4x4mm Set Screws (*Tip 1*) (**make sure the flat spot is aligned with one of the set screws and only use on blue locktite. Apply red locktite to the drive shaft end only and insert into the gearbox input shaft.**) using threadlock. Position the output gear assembly into the right gear box half (**insure the 2 bevel gears are meshed properly and the ball bearings are fully seated in their recesses**) and liberally grease the gears before closing the gearbox. Position the gear box halves over the holes in the end of the tail boom and secure with one 3x10mm Socket Cap Screw and M3 locknut at the end of the gearbox and two 3x12mm Socket Cap Screws with M3 locknuts at the center of the gearbox. Press a steel hollow ball with the flange on the bottom into the Tail Rotor Bellcrank, install a Steel control ball threaded from the bottom of bellcrank arm and install the tail bellcrank assembly on to the tail rotor gear box with one 3x16mm Machine Screw, inserted the ball bearing both side with the apacer inside the bellcrank. and 3x5x0.5T micro washer beteen the bellcrank and gearbox. (**make sure the steel ball is engaged on the pin of the tail rotor pitch slider assembly**).

Step 36 Vertical Tail Fin Assembly

Install the Vertical Fin with two 3x30mm Socket Cap Screws and M3 locknuts through the mounts in the front end of the tail rotor gearbox.

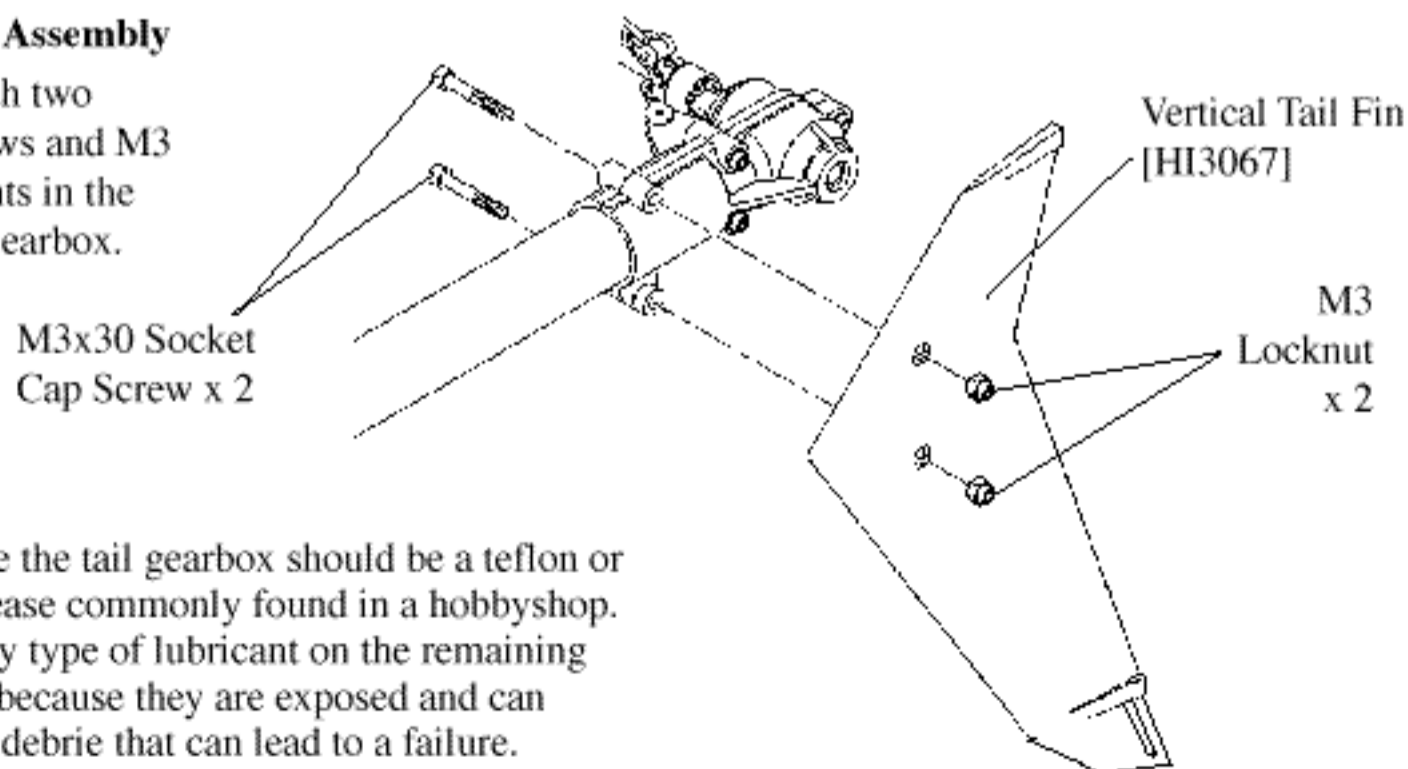

Tip

Grease to be used inside the tail gearbox should be a teflon or light lithium type of grease commonly found in a hobbyshop. Do not use grease or any type of lubricant on the remaining gears on the helicopter because they are exposed and can actually attract dirt and debris that can lead to a failure.

Step 37 Tail boom Final Assembly

Attach the tail boom assembly to the main mechanics by sliding the tailboom tube into the hole in the rear of the upper frame using five 3x25mm Socket Cap Screws and M3 Locknuts, slowly press the tailboom in, being careful to engage the drive wire the flattened end into the tail rotor output gear shaft. The slots on the end of the tailboom will self align with molded pins inside the upper side frame. As the upper frame is assembled at this point, just take your time and the wire will slide in. Once engaged, press the tail boom in completely to fully seat it. Connect the short rudder pushrod at this time.

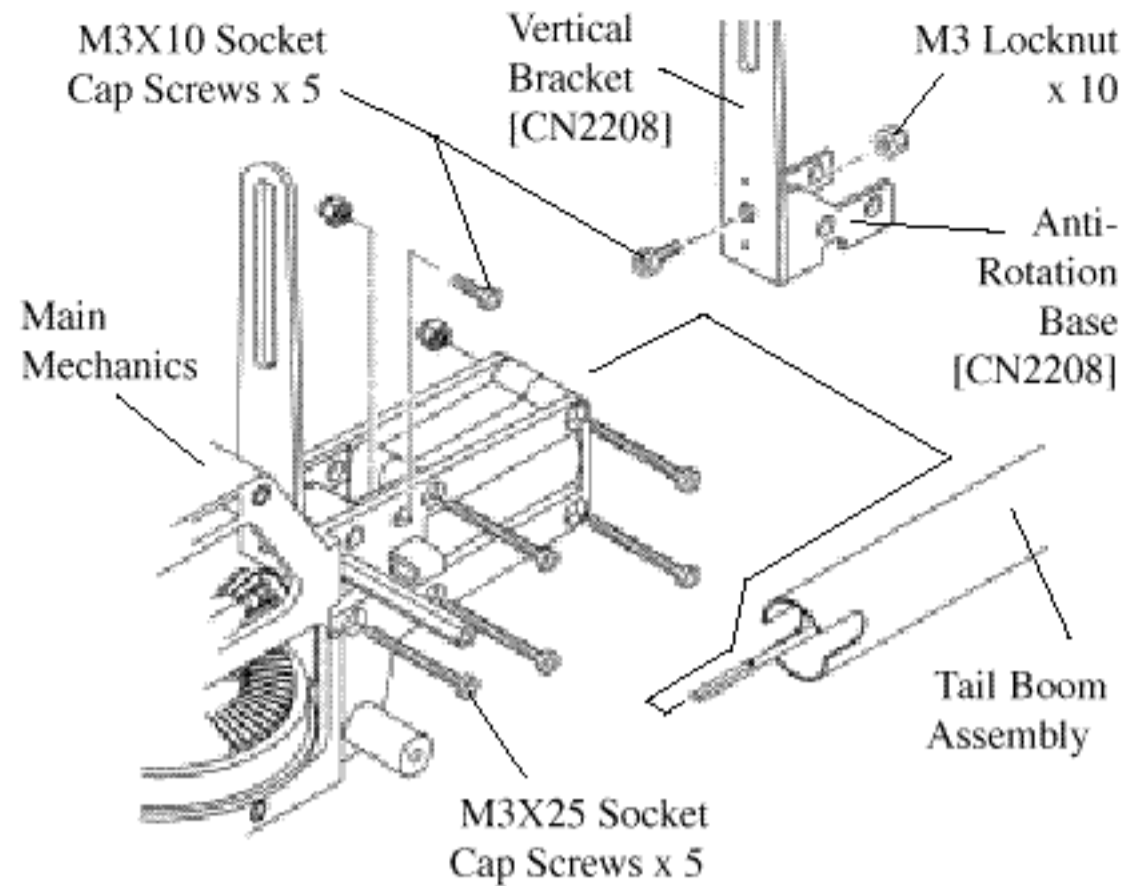

Step 38 Anti-Rotation - 46SE only

Attach the Vertical Bracket to the Anti-Rotation base using one 3x10mm Socket Cap Screw and one M3 Locknut. Attach the bracket assembly to the upper frames with four 3x10mm Socket Cap Screws and four M3 Locknuts. Remember to install the rear pivot bolt on the swashplate with one 3x16mm Socket Cap Screw with 3x4x12mm plastic tube. (46SE only) drill through the end of swashplate with a 2.5mm bit first to make sure the screw will not strip the plastic part.

Step 39 Tail Fins & Support Strut

Insert the two tailboom Strut Fittings into the aluminum strut. Position two of the pushrod guides in front of the horizontal fin and one behind. Attach the Horizontal Fin on the tailboom using two 3x12mm Self Tapping Screws into the Tailboom Clamp and space the fin along the tailboom at the position where the Tail Boom support & Tail Strut is attached. **Note: the mount for the strut is angled, test fit the strut to position the clamp in the correct direction**) then secure the strut one 3x12mm Self Tapping Screw and one 3mm Washer. Attach the lower fitting to the lower frame assembly using two 3x15mm Self Tapping Screws. Finally apply some Zap Ca glue to the fittings onto the strut.

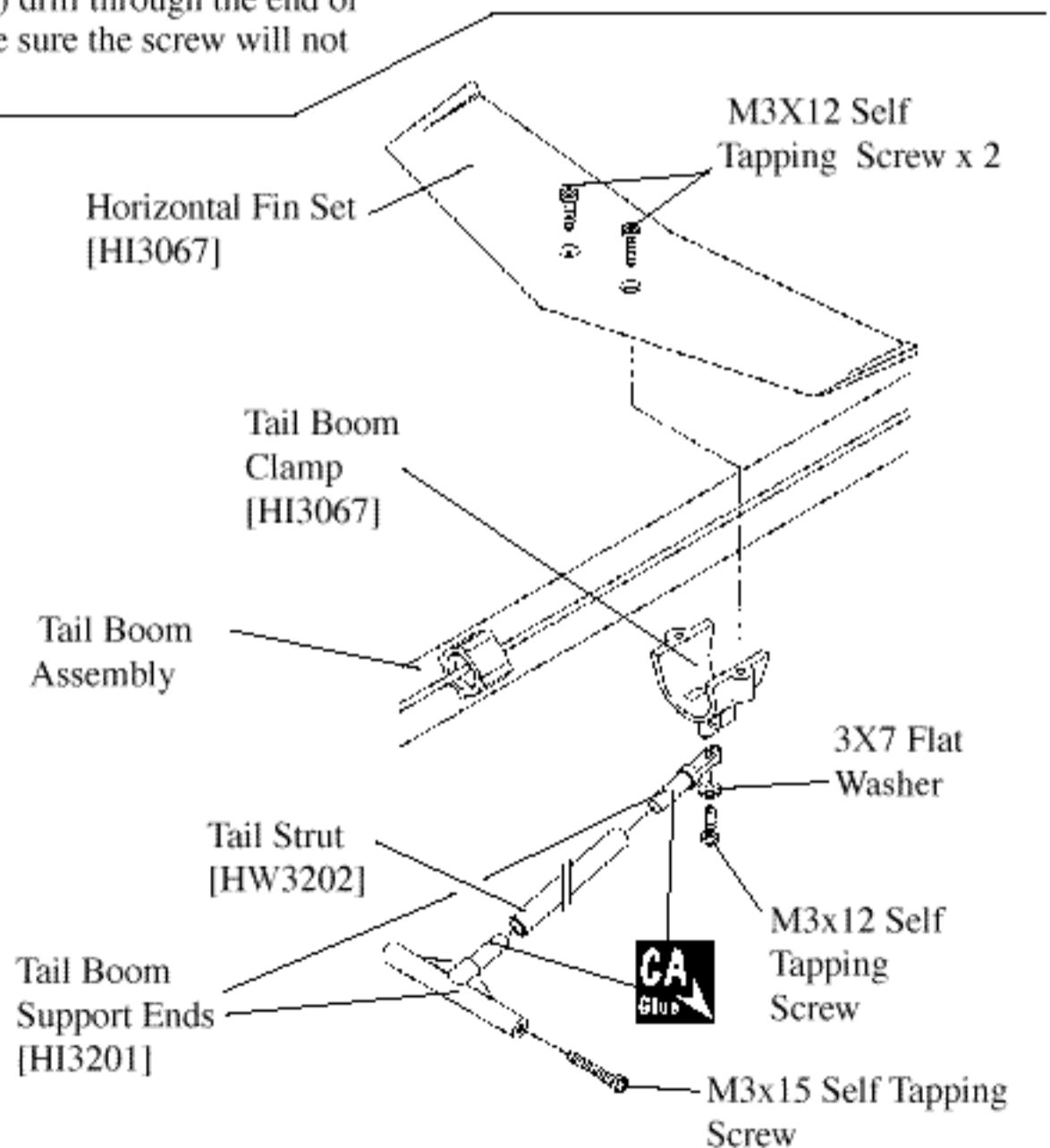

Step 40 Pushrod Setup and Adjustments

Make up all the control pushrods according to the specified lengths shown in the drawing. These are full scale drawings so you can easily match each pushrod to the page. Please note that these dimensions listed from end to end of the plastic rod-ends are to be taken as correct. Fine tuning may be required as the picture size may change when printed. Also some servos offer different horn placements for fine tuning. The numbers in the center of the pushrod drawings are the actual length of the rods to help select the correct pushrod for each control surface.

After attaching the pushrods to the helicopter, the washout arms will be level at 0° collective for 3D flying. Beginners should follow the setup steps and pitch curves for Hovering in the final adjustments.

Note: It is very important that before you install the pushrod linkages that you first charge your radio then remove all the servo horns from the servos and center all the mechanical or electronic trims on the radio.

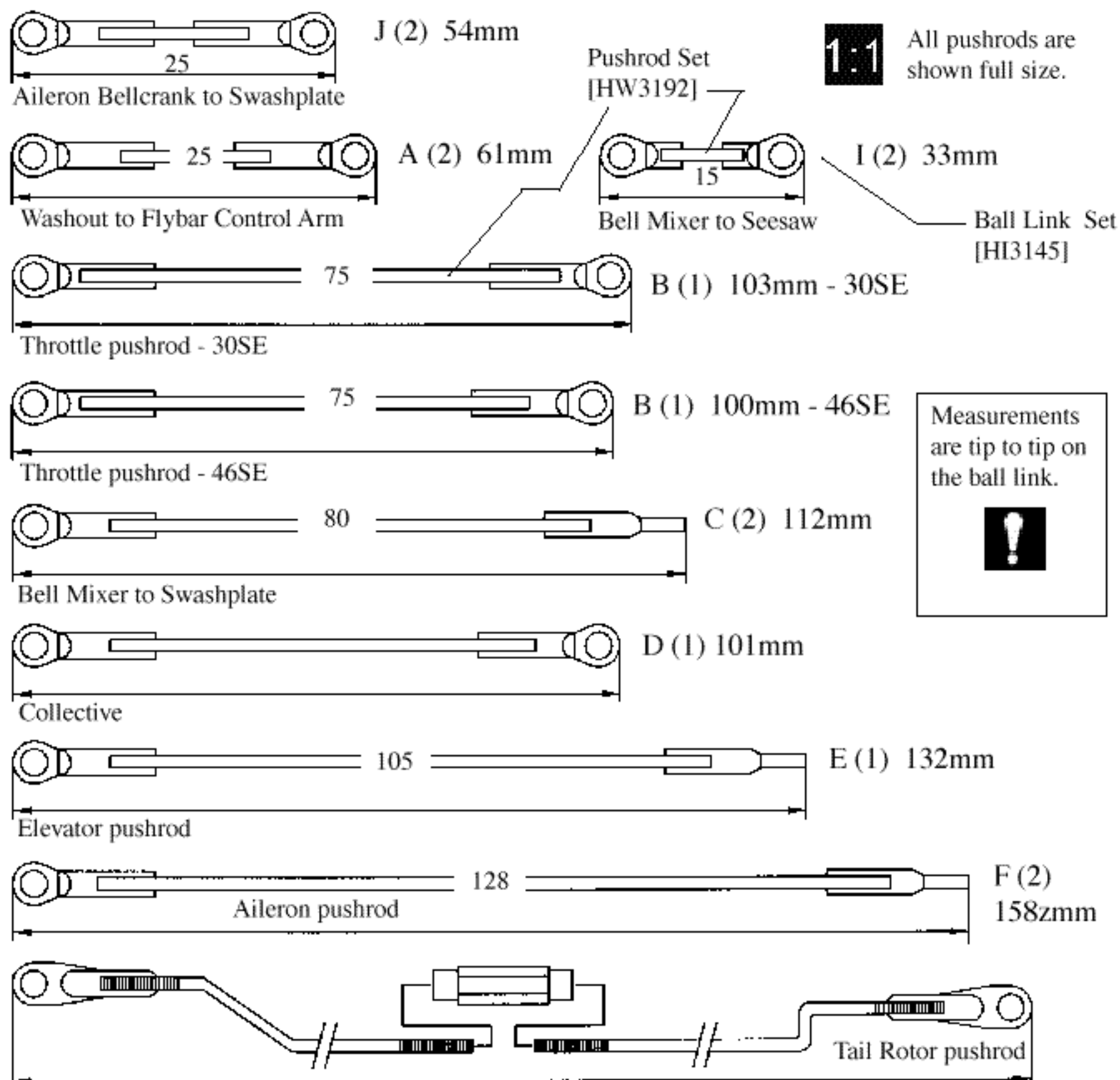

Initial Radio Setup

There are various different radios on the market, each having it's own special setup requirements, we have picked the top three brands to give you the basic setup parameters for the computer class radios. Not all features are available on all radios, use values for functions that do apply. For those that are using either the airplane version or an analog radio some of the following information will still apply.

JR	THR	AILE	ELEV	RUDD	GEAR	PITCH	AUX2	AUX3	
Channel #	1	2	3	4	5	6	7	8	PG2000 Piezo Gyro Direction: R Gain I: (advance) 20 - 85% Gain II: (hover) 30 - 100% General The parameters here are based on JR servos and to be used as a guide in programming your JR radio. Note 1, revolution mixing values based on PG2000 gyro, actual values may varies depending on gyro used. Note 2, Throttle position "S" is for stunt setup & 3D flying only. Strongly not recommended for beginners.
Servo Reverse	R	N	N	N	N	N	N	N	
Travel (ATV)	H	95%	95%	115%	100%	100%	100%		
	L	95%	95%	115%	100%	100%	100%		
Subtrim	(after test flying, adjust the individual pushrods to bring the mechanical trims back to center)								
D/R & Exp	Pos 0	90%	90%	Throttle Hold		(set 5% above idle position)			
	Pos 1	20%	20%	Revo Mix ¹		Up 30%	Down 20%		
		100%	100%						
		0%	0%						
Trim Offset	(store trim positions after test flying)								
Throttle Curve	L	2	H	Pitch Curve		L	2	H	
	Pos N	0%	50%	100%	Pos N	-2°	5.5°	10°	
	Pos S ²	40%	50%	100%	Pos S	-5°	5.5°	10°	
					Pos H	-5°	5.5°	12°	

Futaba	THR	AILE	ELEV	RUDD	GEAR	PITCH	SPARE	SPARE	
Channel #	3	1	2	4	5	6	7	8	PG2000 Piezo Gyro Direction: R Gain I: (advance) 20 - 85% Gain II: (hover) 30 - 100% General The parameters here are based on Futaba servos and to be used as a guide in programming your Futaba radio. Note 1, revolution mixing values based on PG2000 gyro, actual values may varies depending on gyro used. Note 2, Throttle position "IDLE-UP" is for stunt setup & 3D flying only. Strongly not recommended for beginners.
Servo Reverse	R	N	N	N	N	N	N	N	
Travel (ATV)	H	100%	95%	95%	100%	100%	90%		
	L	85%	95%	95%	100%	100%	90%		
STRIM	(after test flying, adjust the individual pushrods to bring the mechanical trims back to center)								
D/R & Exp	Pos 0	90%	90%	TH-HLD		(set 5% above idle position)			
	IDLE-UP	-20%	-20%	REVO ¹		Up 30%	Down 20%		
		100%	100%	TH-CUT (Throttle Cut)		-20%			
		0%	0%						
Trim Offset	(store trim positions after test flying)								
HV-T~TH-CRV	1	3	5	P-AT~PI-CRV		1	3	5	
(Throttle Curve)	Pos N	0%	50%	100%	(Pitch Curve)	Pos N	-2°	5.5°	10°
	IDLE-UP ²	40%	50%	100%		Pos S	-5°	5.5°	10°
						Pos H	-5°	5.5°	12°

Airtronics	THR	AILE	ELEV	RUDD	GEAR	PITCH	7/B		
Channel #	3	2	1	4	5	6	7	PG2000 Piezo Gyro Direction: R Gain I: (advance) 20 - 85% Gain II: (hover) 30 - 100% General The parameters here are based on Airtronics servos and to be used as a guide in programming your Airtronics radio. Note 1, revolution mixing values based on PG2000 gyro, actual values may varies depending on gyro used. Note 2, Throttle position "1" is for stunt setup & 3D flying only. Strongly not recommended for beginners.	
Reverse (SW-R)	R	N	N	N	N	N	N		
Travel (EPA)	H	95%	95%	100%	100%	100%	95%		
	L	95%	95%	100%	100%	100%	95%		
TRIM (Sub Trim)	(after test flying, adjust the individual pushrods to bring the mechanical trims back to center)								
D/R & Exp	Pos 0	90%	90%	Throttle HOLD		(set 5% above idle position)			
	Pos 1	20%	20%	RVH ¹ (Revo Mixing)		Up 30%	Down 20%		
		100%	100%	T-CUT (Throttle Cut)		-20%			
		0%	0%						
Trim Offset	(store trim positions after test flying)								
TH~CU-PL,2,PH	PL	P2	PH	P-F~CU-PL,2,PH		PL	P2	PH	
(Throttle Curve)	Pos N	0%	50%	100%	(Pitch Curve)	Pos N	-2°	5.5°	10°
	Pos 1 ²	40%	50%	100%		Pos 1	-5°	5.5°	10°
						Pos 2	-5°	5.5°	12°

Servo Setup & Adjustments

In the steps 37 through 42 over the next few pages the pushrod hardware will be mounted to the servos horns and ultimately the pushrods themselves. Each step is well described but lets take a few moments to cover a few basic points on setting up individual servos. By this time the radio will have been charged overnight. Recheck that all the servo trims are centered. Each radio manufacturer makes servo horns in different shapes: round, in a cross and sometimes a star, each giving a selection of hole patterns to choose from.

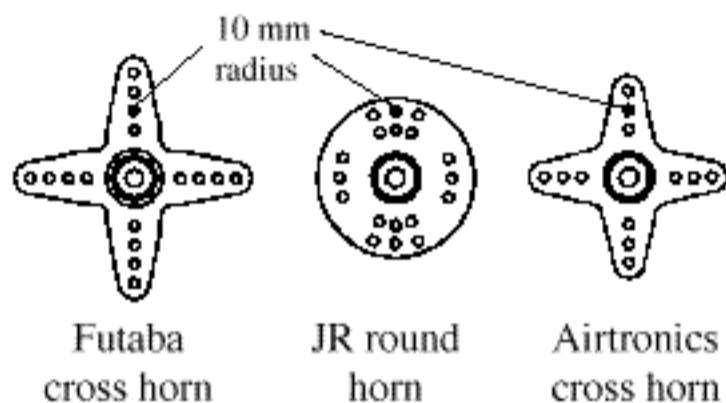

Choosing the correct servo horn only involves whether the particular arm or wheel has the correct hole at the recommended distance measured from servo center to hole center, off by 1/2mm is ok. When using cross horns, many times the remaining arms need to be trimmed off to avoid binding on another servo like throttle and collective. When two pushrods need to be on the same horn but each at an angle, the round wheels are best suited. For wheels that are not predrilled for offsets, measure and drill your own holes. Remember to originally set the wheels or arms centered on the servo.

What we are looking for is equal travel both in the left and right rotation of the servo, this becomes complicated by pushrods attaching to the servo at an angle. To correct this we recommend an angle for the hole location. For elevator and collective, we suggest 10-15 degrees to allow for this "linear" geometry to be set up. A range is given to make it easier for you to just choose an available angle, if this is not possible, simply lift the servo horn off the servo and press into place one "notch" back (counter-clockwise).

We strive to have all the control surfaces setup linearly, this means that as the control stick is moved an equal distance from center that the servo will move a corresponding equal amount of travel. Although this is not clear now, this will become very clear when adjusting the throttle and collective servos movements, commonly called the throttle and pitch curves. At this time it is worth mentioning the danger of the ATV function, Adjustable Travel Volume has solved many setup problems while at the same time has created new ones. Most commonly used for throttle to easily keep the servo from binding, the thing to remember is to keep the upper and lower values should have the same. If the final values are different by more that 10 points then a mistake was made in setting the mechanical limits. Time to go back and recheck.

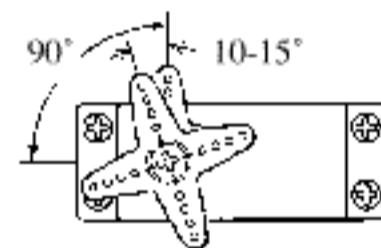

Servo horn shown offset one notch back on the output shaft.

The goal in the end after all the servos are mounted is to have the swashplate sit level or at 90 degrees to the main shaft and have the swashplate move equally fore, aft and side to side. The swashplate will also travel up and down as the collective servo is moved, it is important that in the upper position the washout hub does not contact the rotor head block while at the same time the swashplate remains above the top of the frames to avoid cyclic interference.

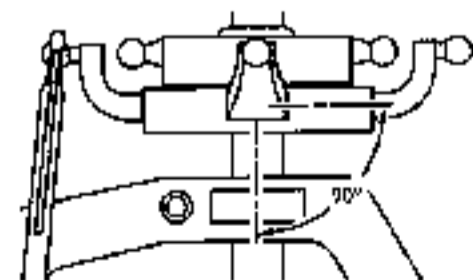

After installing the aileron and elevator pushrods, the swashplate should sit level.

Don't use the pitch gauge until you have installed all the servo horns and pushrods. Pitch settings usually are the last step in completing the basic setup for the helicopter just prior to making the first test flights.

Step 41 Aileron & Collective Linkage

The Aileron linkage controls the side to side tilt of the swashplate which in turn causes the helicopter to pitch to the left or right (hence roll cyclic pitch).

Attach two steel balls with two 2mm nuts at a distance of 10-11mm from the center of the servo (this range may vary depending on your particular radio) and 12-15 degrees ahead of the center of the servo using threadlock. The angle offset will eliminate any stress (wear) on the servo. With the radio turned on and the trim centered, attach the servo horn and Aileron Bellcrank Pushrods (F), some slight adjustment maybe necessary to have the swashplate sit level or 90 degrees to the main shaft when viewed from front or back. Move the Aileron stick completely in both directions to insure that there is no binding in the linkages.

For the Collective Servo, attach one steel ball with one 2mm nut to the servo horn at a distance of 10-12mm from the center of the servo using threadlock. With the Collective/Throttle stick on the radio in the center press the servo horn onto the collective servo so the ball is at 75-80 degrees to the servo as shown. Attach the Collective Arm Pushrod (D) and move the Collective stick completely in both directions to insure that there is no binding in the linkages.

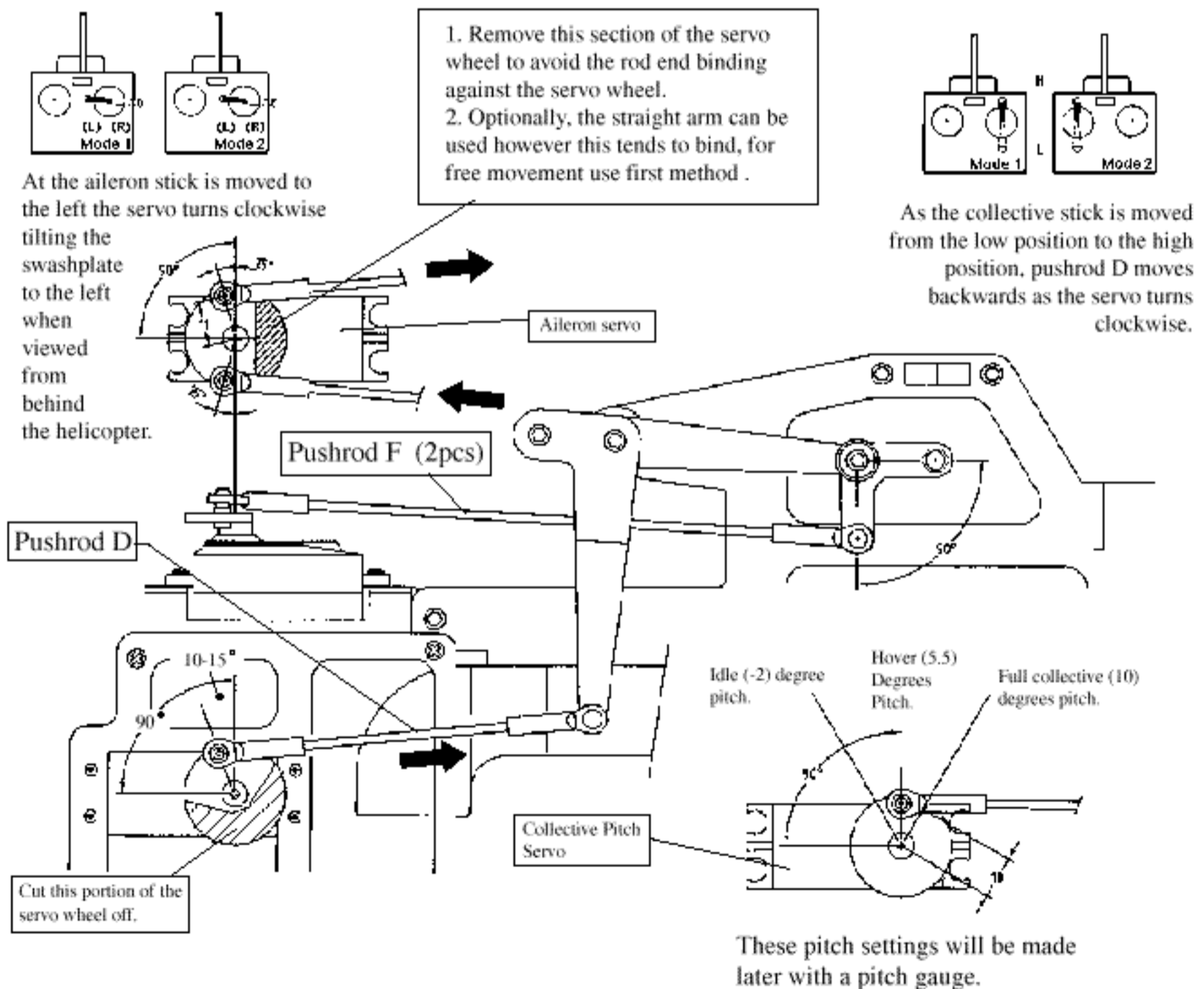

Step 42 Rotor Head Linkage & Elevator Linkage

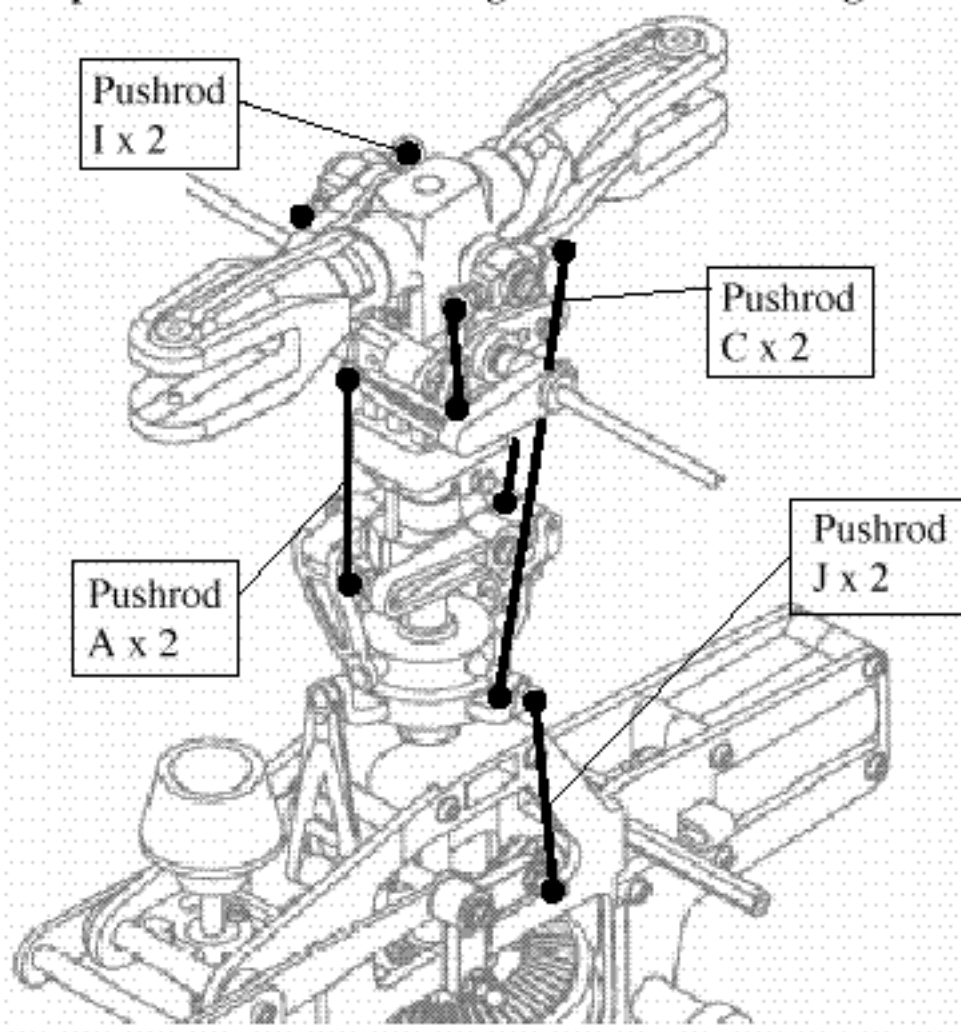

When attaching all pushrods, make sure same length pushrods are actually the same length from the beginning otherwise it will be difficult later to figure out where the linkage problems are coming from. Attach the following:

- 2 Flybar to Washout pushrods (A),
- 2 Bell Mixer to Seesaw pushrods (I),
- 2 Bell Mixer to Inner Swashplate pushrods (C),
- 2 Aileron Bellcrank to Outer Swashplate (J).

Step 43 Rotor Head Linkage & Elevator Linkage

The lower linkages are shown here to illustrate the general setup and layout of the servo linkages to the respective control surfaces.

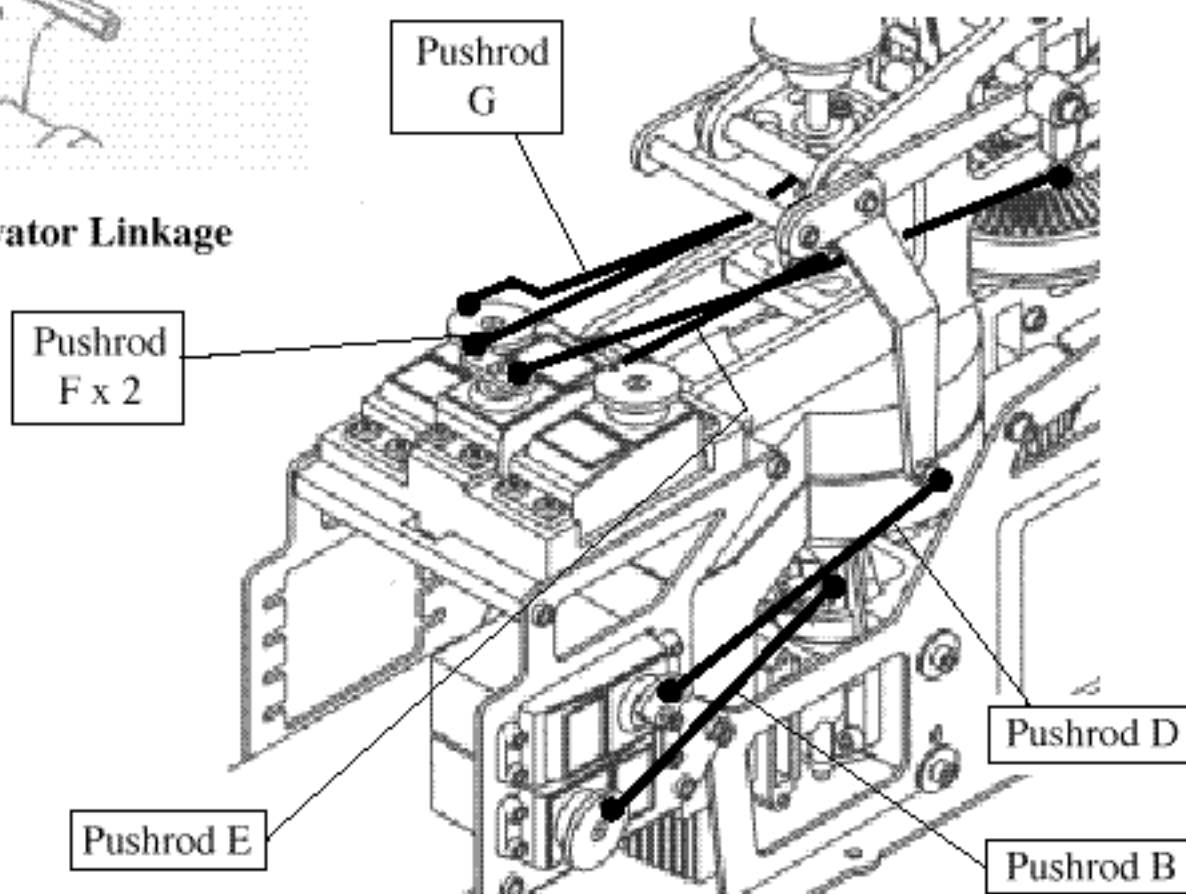

Step 44 Elevator Linkage

The elevator pushrod controls the tilt of the swashplate forward and backward which causes the helicopter to pitch forward or backward (hence fore-aft cyclic pitch).

From Bag 4, use a servo horn in the shape of a cross and trim the 3 of the 4 arms off. Install one steel ball and one 2mm nut at a distance of 10-11mm from the center of the servo (**mount the ball directly against the bottom of the servo arm and tighten the nut on top, trim off the screw level with the nut to avoid hitting the Aileron pushrods**), remember to use threadlock. With the radio on and the elevator trim set at the center, attach the elevator pushrod (E) to the elevator bellcrank, then attach the servo horn at an angle of 10-15 degrees ahead of the center of the servo (the offset enables an equal throw of the swashplate). **It is important that the swashplate sit at 90 degrees to the main shaft.** The elevator bellcrank will be at an angle when correctly setup.

Elevator Linkage Diagram

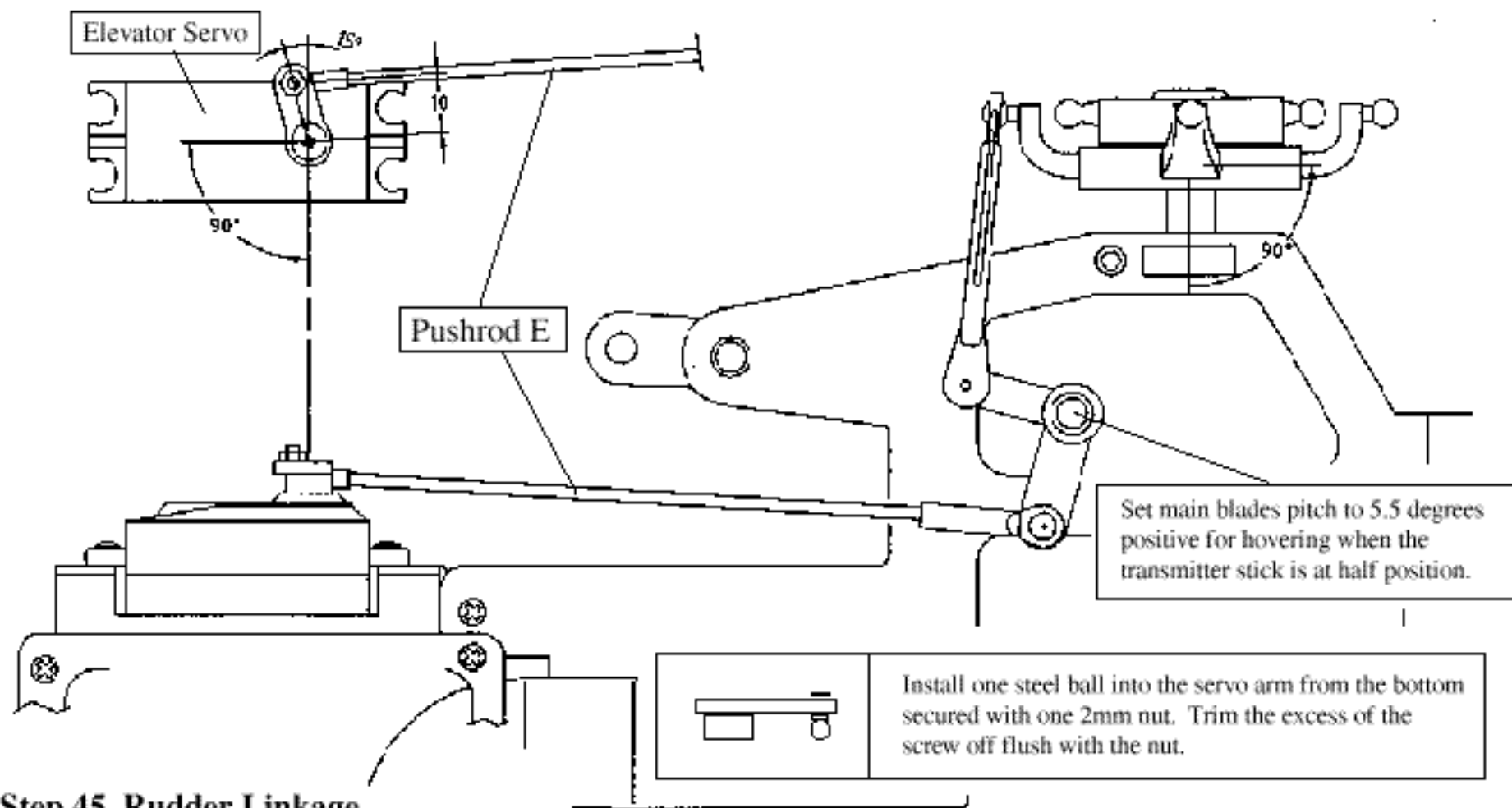

Step 45 Rudder Linkage

The Rudder linkage for the tail rotor is set up the same for both Helicopter and Airplane radios, the pushrod changes the pitch of the tail rotor blades to increase or decrease the torque compensation to rotate the nose of the helicopter about the main shaft.

Use a servo horn in the shape of a cross and trim the 3 of the 4 arms off. From Bag 4, install one steel ball and one 2mm nut at a distance of 10-11mm from the center of the servo remember to use threadlock. The Rudder Pushrod (G) will at this point be installed up to the servo tray from Step 37 attach the special ball link provided to the servo end. Having the radio on and the rudder trim centered press on the servo horn onto the servo set at 90 degrees to the servo and adjust the length of the pushrod to align the rudder bellcrank to 90 degrees as shown in the diagram.

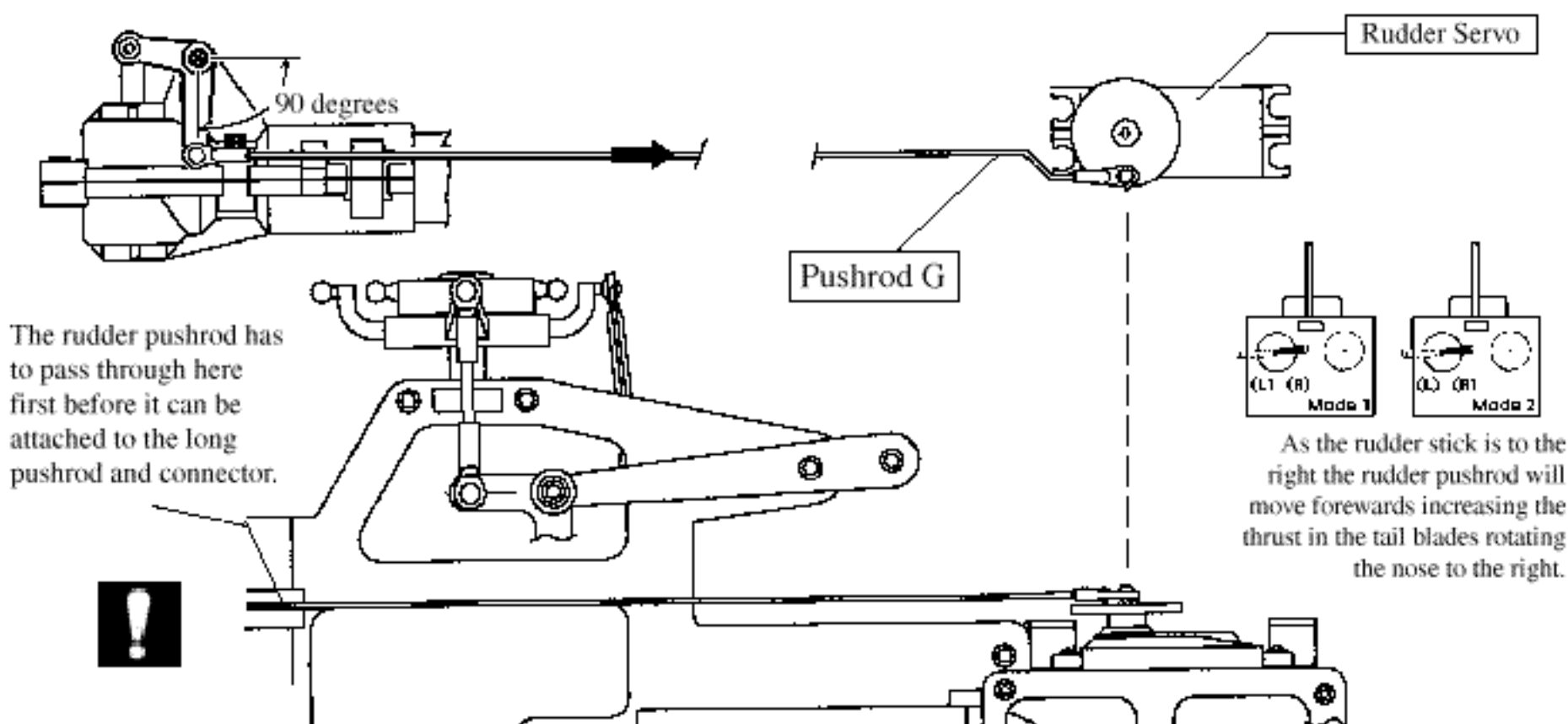

Step 46 Throttle Linkage

From Bag 4, attach one steel ball one 2mm nut, to both the Throttle servo horn and the Throttle Extension from Step 17 using threadlock. Position the ball at 10mm from the center of the servo and in the outermost hole on the metal throttle arm. With the radio on, and the throttle stick centered and the trim in the center, press the servo horn onto the servo so the ball is at 90 degrees to the servo (the hovering position). Move the throttle stick to the low/idle position and press the Throttle Pushrod (B) onto the steel balls. Check that in the low position the carburetor has about a 1mm wide opening for idling and finally as the trim is moved fully down the carburetor closes completely to shut the engine off. Also check that in the high position the carburetor is fully open. The throttle extension nut may have to be loosened and the lever repositioned to operate as recommended.

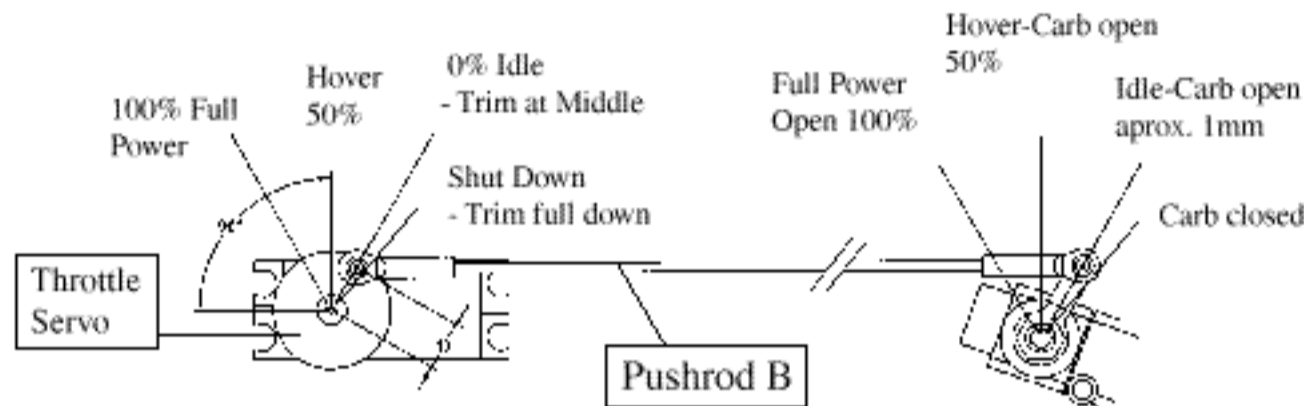

Tip

Pushrod B will vary in length slightly as the position of the carburetor is different for each engine manufacturer. Following the above instructions will allow you to get the carburetor setup correctly.

Step 47 Care and installation of Hurricane Carbon Blades

The Main Rotor Blades included in the kit are pre-finished and balanced carbon rotor blades. Care must be taken in handling composite blades to keep them in excellent condition. Do not compress any portion of the blade from the trailing edge to the center spar as it is hollow. In the event of a crash-landing discard rotor blades, scuffs or marks on the blade tips maybe the only visible damage however there is no method for inspecting the internal structure of the rotor blades for stress cracks which can cause total blade failure at an unpredictable time. Also, do not store rotor blades indoors in direct sunlight or near heat sources for any period of time. Simply wipe blades clean after flying.

To install blades on the 30SE, (**press out the brass bushing from the blade bolt hole**) place one 4x20mm washer on top and bottom of the 30SE blade before sliding into the rotor grip. To install both blades, insert one 4x30mm Socket Cap Screw through the top grip and secure using one 4mm Locknut. Repeat for opposite rotor blade. Blade bolt tension will affect how the blades perform. To set proper tension, start from loose blades (bolt is loose enough for the blade to pivot freely from the grip) and tighten the bolts a little at a time until the blades will hold straight as the helicopter is tipped on its side. Slightly tighter is good. Too tight and a vibration will occur, too loose and a tail boom strike can happen. Tail blades can be set the same way.

CN2400 Hurricane
Symmetrical 550mm - 30SE
CN2414 Hurricane
Semi-Symm 550mm - 30SE

CN2412 Hurricane
Symmetrical 600mm - 46SE
CN2413 Hurricane
Semi-Symm 600mm - 46SE

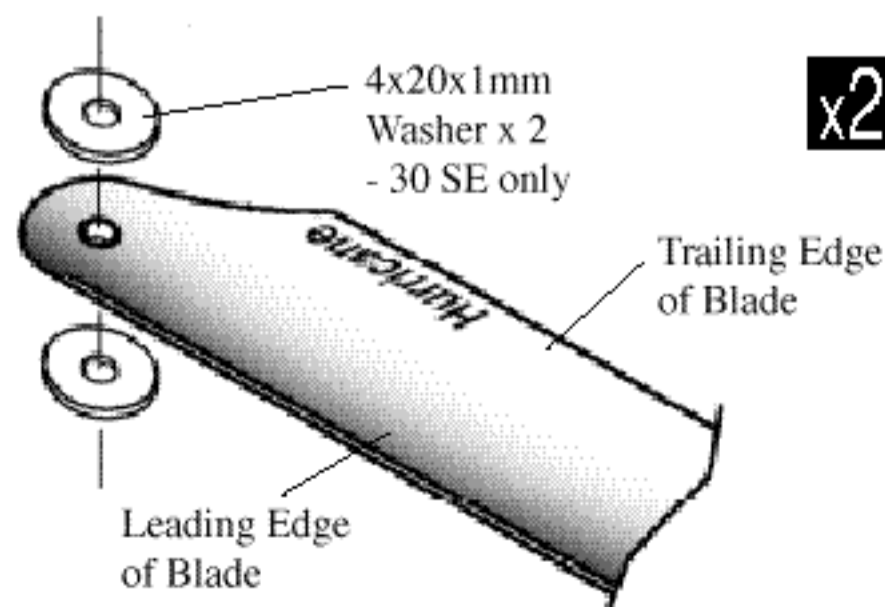

Each kit contains symmetrical rotor blades for sport and aerobatic flying. For your convenience you can also use semi-symmetrical for smooth aerobatics and scale flying.

Step 47 Canopy & Decals

The Canopy has a line molded into the plastic to follow when trimming the windshield part out, be careful, trim the innermost line leaving the 6mm band for attaching the windshield. Using a sharp hobby knife carefully scribe a line several times into the plastic until you cut through the material. Similarly trim the clear windshield along the provided line, to make it easier to see the line, use a non-permanent marker and trace the line, any extra ink can be removed with rubbing alcohol. Test fit the canopy together by taping it to the canopy, some additional trimming maybe necessary to get a good fit. From Bag 5, the inside canopy mount can be installed (**note the direction of the mount**) with two 3x6mm Self Tapping Screws,(**note: the location for the mount has to be moved 8mm forward of the marked location on the bottom of the canopy**). The clear windshield can be attached using six 2x6mm Self Tapping Screws in Bag 4, drill six 1mm holes at the locations shown.

To improve the adhesion of the decals to the body, peel the decal off the backing and apply one coat of spray adhesive (spray glue) to the sticky side, commonly found in your hobbyshop. For those who would prefer to paint the canopy.

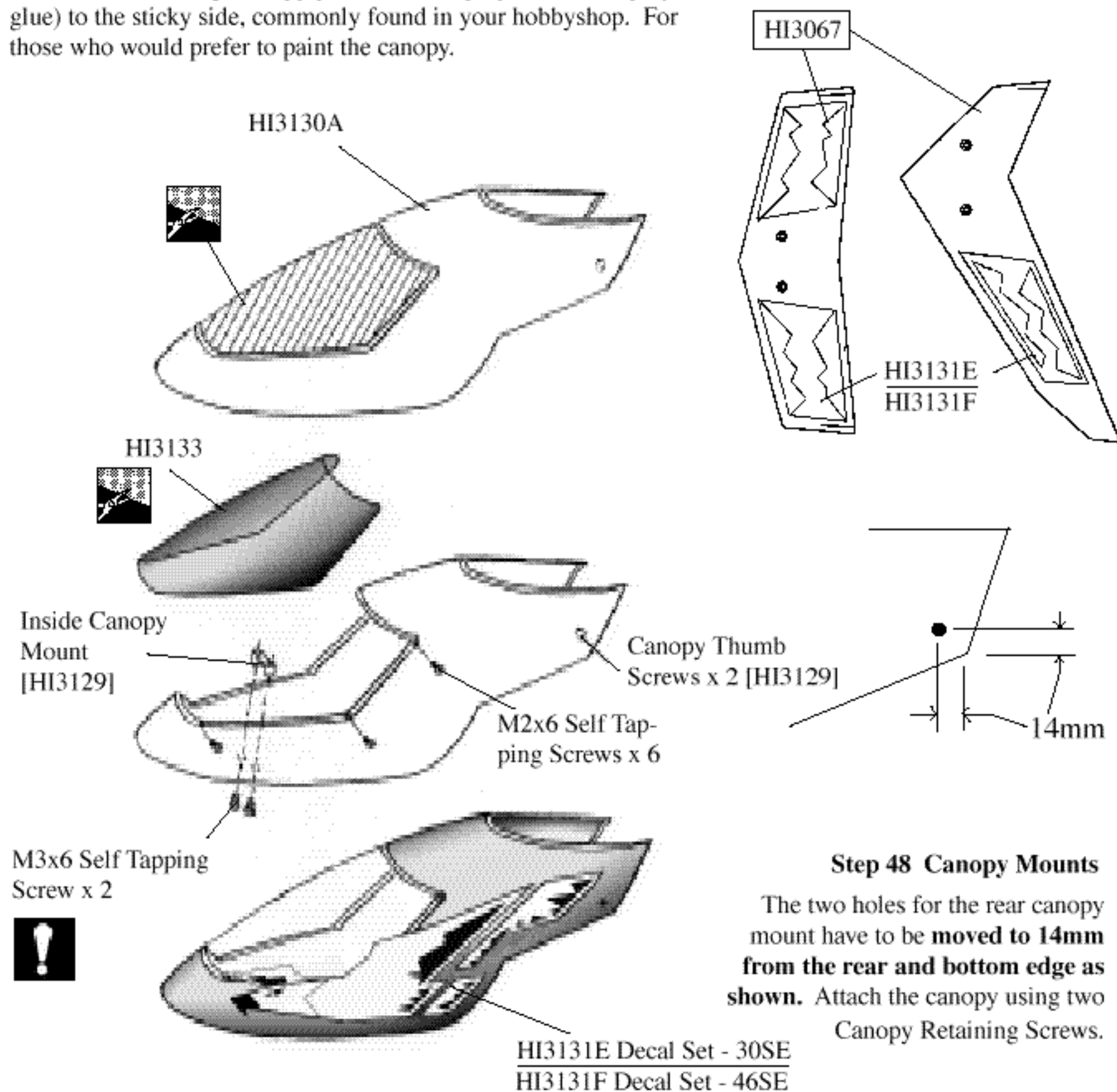

Step 48 Canopy Mounts

The two holes for the rear canopy mount have to be **moved to 14mm from the rear and bottom edge as shown**. Attach the canopy using two Canopy Retaining Screws.

HI3131E Decal Set - 30SE
 HI3131F Decal Set - 46SE

Radio Components & Balancing

Gyro Having completed all the assembly for the helicopter, all that remains is mounting the radio receiver, receiver battery and the gyro.

Mount the gyro on the radio tray, some rearrangement from the picture is required to mount everything. If using the PG2000, the gyro can be mounted between the collective & throttle servos and the right servo frame side. It is extremely important that the gyro is attached using only the supplied two sided tape onto a clean flat surface. Keep all wires and components away from the gyro housing. Do not use straps or elastics to secure the gyro.

Install the gyro using double sided foam tape (supplied with gyro) put a full strip along the bottom of the gyro unit and press onto the surface. For a good bond make sure both surfaces are clean and dry.

Optional Equipment
PG2000 Piezo Gyro -
CN2018 or Heading
Lock piezo gyro
#CN2238

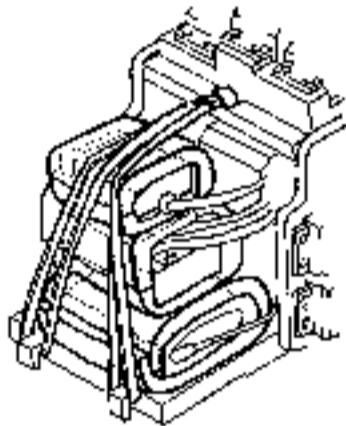

Receiver, Battery Pack and Piezo Gyro

Using the foam rubber, wrap the battery pack, receiver and gyro controller separately, allowing wires to be collected and tied together. Using two elastics looped through the front of the top servo tray, secure the components to the two hooks on the lower servo tray. ** The actual arranged components will be different than the picture illustrates.

Balancing the Rotor Head

Balance is the most important part in maintaining a safe and reliable helicopter. First check the blades for balance, this can be done on a balancer but can be done directly on the helicopter by tipping the helicopter on its side at the edge of a table and attaching the blades. Temporarily remove the bolt to secure the autorotation bearing so the head spins free (remember to replace this bolt!!). If one blade stops at the same spot add some tape to the lighter blade to balance the rotorhead. The same procedure can be used to balance the flybar without the main blades attached.

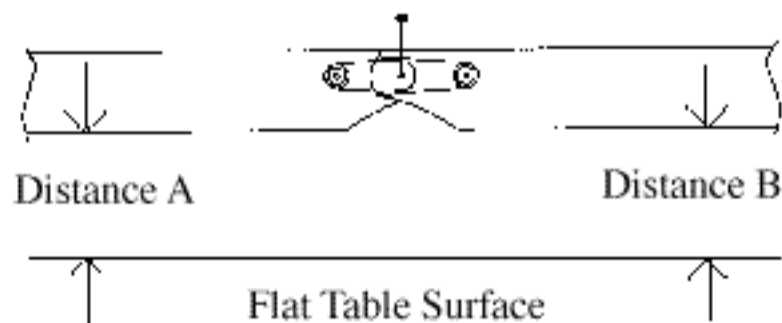

Bolt the blades together and support by the ends of the bolt off a flat surface. If one blade tips to one side add small pieces of tracking tape until both blades hang an equal distance from the table (Distance A = B). Attach the Main Blades to the helicopter using two 4x30mm Socket Head Cap Screws and M4 Locknuts.

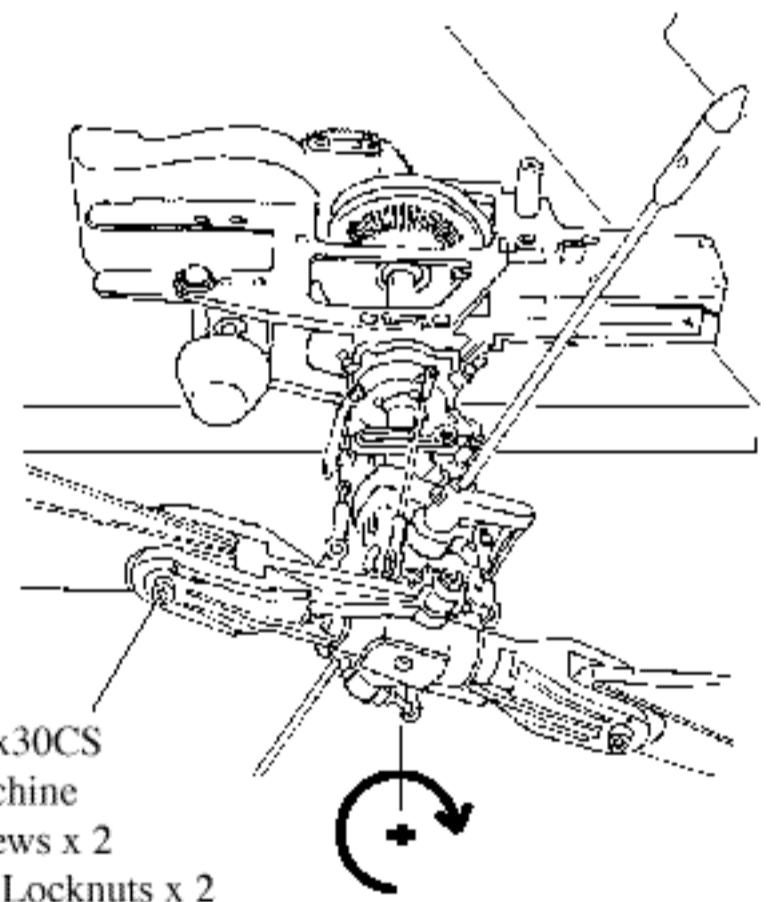

When attaching the main blades, the direction of rotation is clockwise, when looking on top of the helicopter.

Final Adjustments - Radio Setup

Now that the servo installation into the helicopter is finished the following pages should be reviewed. As various types of radios can be used to setup the helicopter, some of the following information may not apply.

Servo Direction (Servo Reversing)

Check that all servos move in the correct directions, see the diagrams on pg 28-31.

Dual Rates

For beginners (using the flybar weights) the dual rate values should be set at 100% for both switch positions until hovering has been mastered.

Normal position: (high rate) 100%
Switch position 1: (low rate) 75%

Exponential

The exponential function allows adjustment of how sensitive the cyclic controls are when the machine is hovering. This should be left at 0% (linear) until all trimming is complete.

Sub Trims

The sub trims on the outside of your transmitter are used to fine tune the servo center positions while testing or in-flight. If the trim has to be moved more than 2-3 divisions then readjust the linkage length to set the trim back in the center.

Travel Adjustment (endpoints)

Using endpoints to adjust to the limits of how far the servo is allowed to move is very convenient for fast set-up. If binding occurs simply reduce the travel in that direction. ** Note: by changing one side only (high or low stick) the servo travel is no longer linear which will tend to make that control surface unstable. It is better to set the high/low adjustments the same, or make actual pushrod adjustments.

Pitch & Throttle Curve Adjustments

The ultimate goal for adjusting the curves on your helicopter is to reduce how much the tail rotor moves during flight and aerobatics. This leads to maintaining a consistent main rotor RPM which can only be achieved through adjusting the individual values which control the pitch and throttle at a given stick position.

Pitch Curve Adjustment

The following chart shows the values for the collective pitch measured in degrees which are made on the helicopter using a pitch gauge. The Travel Adjustment function (if available makes these settings easy). For the beginner it is recommended to set the low stick position to 0 degrees to avoid damaging the helicopter while reducing the power during the first few flights. These settings will need slight adjustment to keep the helicopter at a consistent height at mid stick.

Pitch Curve Values

Flight Mode	Setup Method	Low Pitch (low stick)	Hovering (mid stick)	High Pitch (high stick)
N	Beginner	0	5	9
N	Hovering	-2	5.5	9
1	Stunt & Aerobatics	-10	5.5	10
2	3D**	-10	0	10
H	Autorotation	-10	5	12

(N - Normal flight mode, 1 - Stunt mode one, 2 - Stunt mode two, H - Throttle hold-autorotation)

Note** In order to avoid binding at high pitch angles the flybar control arms need to be reset at an angle of 10-15 degrees down from parallel.

Pitch Curve

Hovering - (linear) Normal Flight Mode

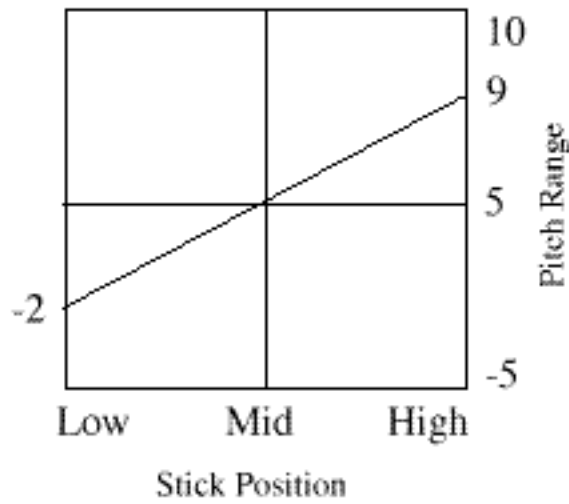

Aerobatic Flying - Flight Mode 1

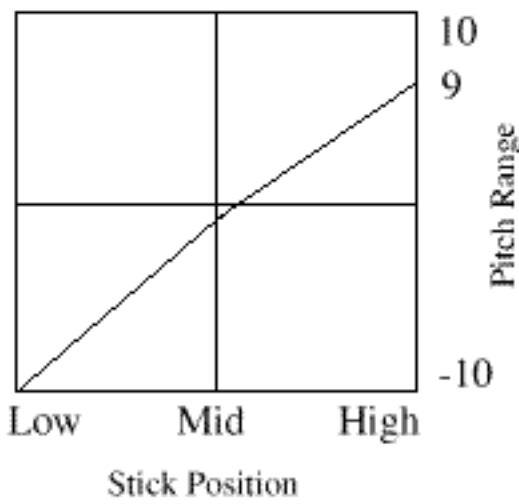

3D Flying - Flight Mode 2

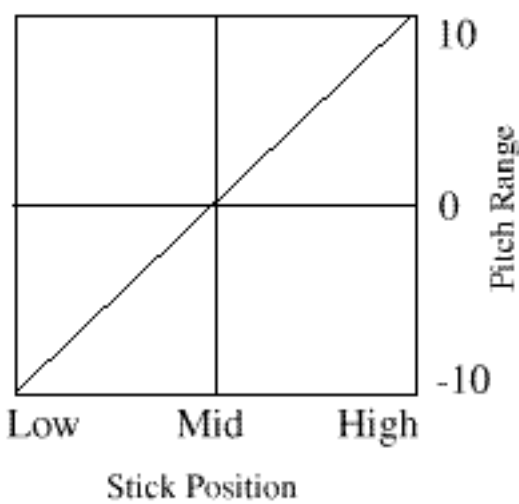

Autorotation - Throttle Hold

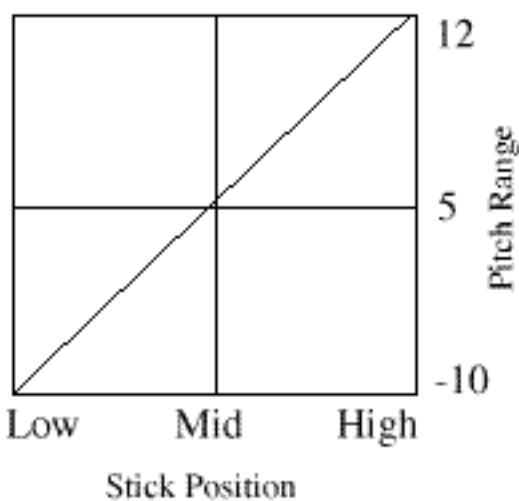

Throttle Curve Adjustments

After several tanks of fuel the engine will be run-in, at this time you can modify throttle settings but remember that the smoother the engine the less adjustment required. Not all engine / muffler / fuel combinations are the same which will shift some of the values shown below.

Throttle Curve

Hovering - (linear) Normal Flight Mode

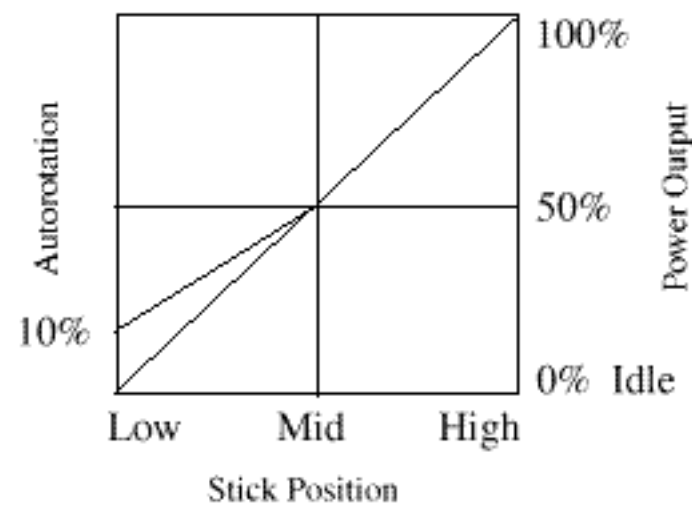

Aerobatic Flying - Flight Mode 1

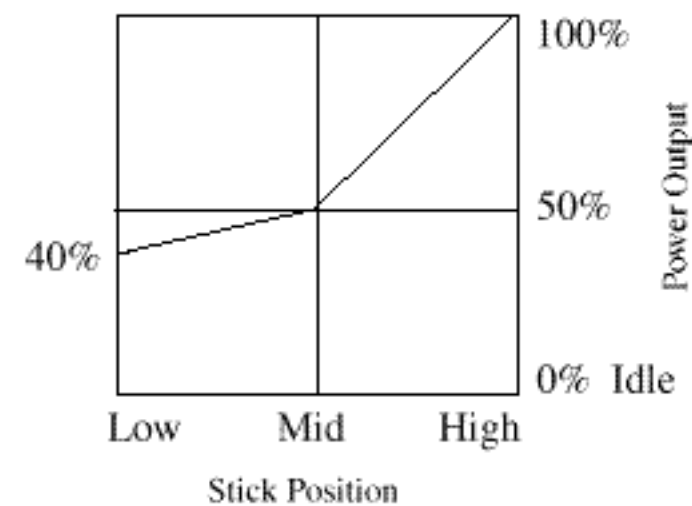

3D Flying - Flight Mode 2

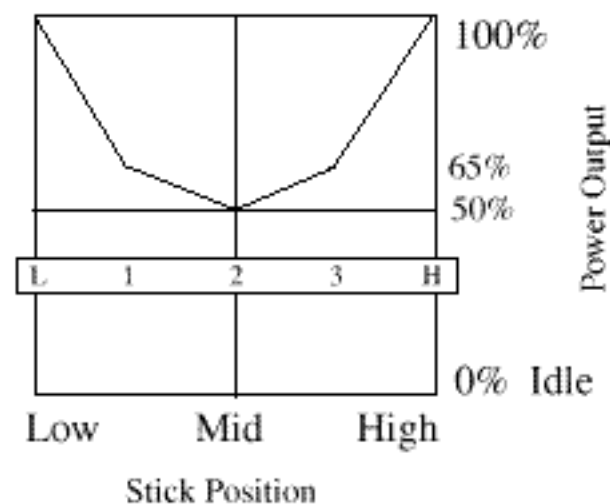

Tail Rotor Setup

What separates airplane radio equipment from the helicopter version is in the control of the individual curves discussed earlier and in the Revo-mixing*.

Take a moment to consider the helicopter hovering in front of you.

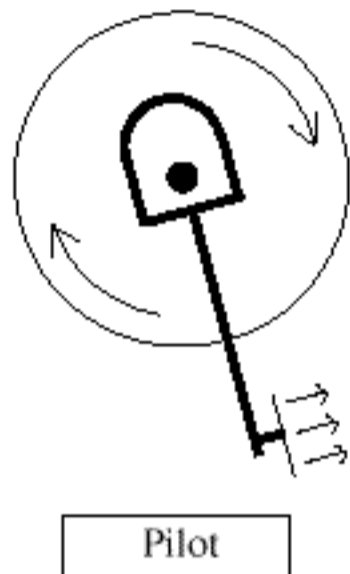

1 Nose rotates left at hover.

Problem: Not enough pitch in tail rotor to match torque setting of engine.

Action: Increase pitch by shortening the rudder pushrod.

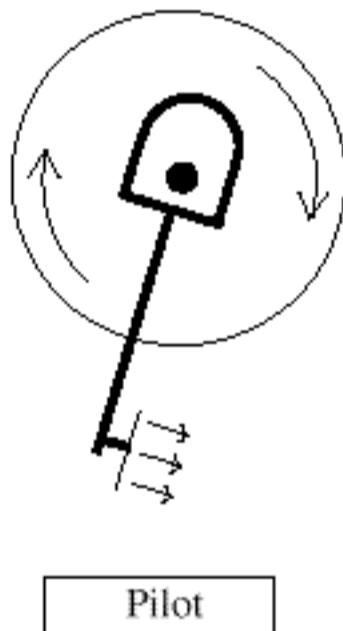

2 Nose rotates right at hover.

Problem: Too much pitch in tail rotor to match torque setting of engine.

Action: Decrease pitch by lengthening the rudder pushrod.

Once the tail rudder pushrod is adjusted correctly so the tail does not rotate (don't consider wind now) the revolution mixing can be adjusted.

*Revolution Mixing

The revolution mixing function allows the helicopter to climb or descend without the tail rotating. These settings are set when using regular piezo rate gyros, if using a Heading Hold gyro remove all tail mixing. There is a high & low setting on the helicopter radio. The values shown will vary depending on engine, blade pitch and fuel but provide a starting point for the beginner.

For each flight mode setting, there will be different Revo-mixing amounts. For forward flight the settings will be lower than hovering due to the aerodynamic forces effecting the helicopter. Here is a starting point for revo values:

High Stick Setting:	40	Normal Flight
Low Stick Setting:	20	Mode

These values correspond to the total travel for the tail rotor pitch. To adjust the high setting, hold the helicopter at hover and increase the throttle so the helicopter climbs steadily. Notice the direction the nose rotates:

	Nose rotates	
High & Low	left	increase revo value to increase tail pitch.
	right	decrease revo value to decrease tail pitch.

To adjust the low setting, start from a high hover and decrease the throttle to descend, notice which direction the helicopter rotates.

Gyro Gain Adjustment

The gyro assists in holding the tail rotor, actually compensating for changes in wind direction or quick movements.

First check that the gyro is installed correctly by watching the rudder servo. While holding the rotor head move the rudder stick to the right and observe the direction the servo arm moves. Now quickly rotate the nose to the left, the servo horn should move in the same direction. If the rudder servo horn moves in the opposite direction reverse the gyro direction.

Generally the starting setting for the gyro gain is 60%, keep increasing the gain setting until the tail starts oscillating back and forth, then reduce the setting slightly.

Problem: Tail rotor makes sudden uncontrolled rotations.

Solution: The gyro direction is possibly set in the wrong direction.

Before Flying your Helicopter

Before each flight, check that all bolts and screws are tight. Simply flying your helicopter, will loosen any screws which are not threadlocked or secured with a lock nut.

First Flights For the beginner pilot, a training pod is strongly recommended to assist in learning to hover the helicopter with substantially reduced risk of crashing. These systems provide an on ground training capability to allow pilots to become familiar with the helicopter before actually leaving the ground.

Starting Your Engine

Fuel 15-30% Helicopter fuel is recommended containing more oil. Use a fuel filter between the fuel gallon and the heli to remove any dirt that could stall the engine. Fuel the helicopter by removing the fuel line from the carburator and replace when finished.

Needle Valve Following the engine manufacturers instructions, turn the main needle valve until closed and open to the setting the instructions call for. Different engines will have different settings.

Radio Always turn the transmitter on first, then the helicopter & gyro and reverse when finished, turn off the heli & gyro first then the transmitter. If the radio acts erratically or intermittent, find the problem before starting the engine.

Glow Plugs Using a glow plug connector, remove the canopy or optionally use a remote glow plug connector to heat the glow plug. Warning!! glow plugs operate at 1.5V not 12V.

Engine Before starting the engine, check the correct direction of rotation and make sure the electric starter is turning the same direction.

Starting Start the engine from low throttle with the trim centered. Holding the rotor head in one hand, angle the starter and press down slightly to engage the starting shaft into the fan. Start the electric starter until the engine starts. If the engine does not start recheck all previous points. The main blades will not turn until the engine RPM is above idle.

Stopping To stop the engine, with the throttle stick in the low position, move the trim all the way to the low position.

If the Engine Does Not Start

Q. The engine does not turn easily with the starter.
A. The starter battery may be too weak or the engine is flooded. For flooding, remove the glow plug and turn the engine over several times to clear the combustion chamber of fuel and retry.

Q. The engine rotates and tries to start but doesn't.
A. The glow plug may be getting old. The glow plug batteries are weak. The starter may be turning the wrong direction.

Q. The engine just does not start.
A. The glow plug may be burned out. Fuel may not be getting to the engine, check for a clogged fuel line, dirt in the carburator or the main needle needs to be opened out slightly.

Q. The engine starts but immediately stops.
A. There is a clog in the fuel line, the carburator is not open enough at idle- open the throttle trim by 1-2 clicks. Helicopter engines have a low speed needle which is factory set, beginners should not adjust it!!

Adjusting the Blade Tracking

Pitch In steps 42-47 you setup the pitch range using a pitch gauge and setting the pushrods on the servo horns at specific distances. Once the helicopter is flying the pitch setting have to be fine tuned. Using appropriate training gear, increase the throttle until just before the helicopter lifts off and sight the rotor disk from 15' back. If there appears to be 2 rotor disks then adjust Pushrod C until only one disk appears. Using colored tape mark one blade so you can adjust the correct blade.



Starting the engine for the first time.

The model engine is the single most difficult part of model helicopters to the beginner, second only to learning to fly. For this reason we have taken the time to go through starting the engine the first time with you to help you to understand the basic operation and tuning of the engine.

Items to recheck:

1) Servo direction for the throttle channel. Turn on the transmitter switch, then the switch on the helicopter, move the throttle/collective stick to the low position, the carburetor arm should look exactly like the diagram (1a). Watch the throttle servo. As you raise (increase) the left stick the throttle pushrod will move towards the front of the helicopter, all carburetors work the same, as the throttle arm is rotated by the throttle pushrod, the barrel of the carburetor rotates counter-clockwise as it opens. If this does not happen you need to reverse the servo direction and reset the throttle arm in Step 20. Starting the engine at full power will possibly damage the engine and will damaged clutch components on the helicopter.

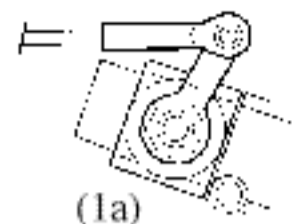

2) Fueling the engine. Open the gallon of fuel and insert draw line from the fuel pump into the fuel, remove the fuel line at the carburetor inlet and connect to the fueling line of the fuel pump. Fill the tank until you start to see bubbles moving in the pressure line to the muffler. Reverse the pump for 1 second and disconnect the lines starting with the fueling line and reconnect to the carburetor. Recap the fuel to keep moisture out. Only fuel the model when you are setup and actually ready to start the engine, it is common for the carburetor to fill with fuel while sitting on the bench over a brief period of time. More common is the engine flooding while trying to start. This the case as you are starting with an electric starter the engine initially turns easily but soon slows down.

3) Last pre-flight checks. Make sure that both the radio Tx and Rx have been charged overnight and the glow starter (if rechargeable). Do a range check, walk away from your helicopter with the antenna fully collapsed to 30 paces and have someone verify that all control surfaces are operating. If you do not make this distance have an experienced modeler check over your setup, do not fly until then.

4) Cranking the engine over. When a brand new engine does not start there are only three major possibilities: a) the glow plug is not hot enough or already burned out or b) fuel is not getting to the carburetor or c) too much fuel is entering the carburetor. This is assuming you have gone through step 1 in this page. Connect the starter to a 12Volt source and verify that the starter will turn the starting cone counter-clockwise. Connect the glow starter connector to a 1.5Volt source or use a rechargeable glow starter. Do not connect yet.

- Move the throttle stick to the low position with the trim in the center.
- Look at the fuel line entering the carburetor, is there fuel in the line, if not pull the fuel line off and check.
- If there is no fuel in the line, reconnect and push down on the start cone and turn the engine by hand until you see fuel entering the carb. make one more revolution. Putting a finger over the muffler exhaust hole will help.
- Connect the glow starter to the glow plug, place one hand firmly on the rotor head, **absolutely** at all times keep your hand on the rotor head, should the engine start anywhere above idle you will only have a few seconds to put the starter down and pull the fuel line off the carburetor line going to the engine. It is a good idea to make sure you are standing/kneeling on the fuel line side.
- Place the starter on the starting cone and push down, before you start, rotate the cone with the engine engaged backwards (clock wise) until you feel the compression increase.
- Press the button on the electric starter, there will be an initial popping sound as the engine turns over and within a few seconds the engine should start. If it does, while holding the rotor head put down the electric starter and move the throttle trim down until the engine continues to run at the lowest speed without quitting. If the engine starts to die simply move the trim up one or two clicks. Do not move the throttle stick from the low position.

5) The engine does not start. Do not continue to crank the engine over if it does not start.

- a) Remove and check the glow plug, is the glow plug dry or wet? Connect to the glow starter or the glow connector and verify that the element glows a bright orange to a white color, if you get an orange glow then your glow starter is not supplying enough power to the glow plug.
- b) If the glow plug is wet, then the engine is receiving fuel. If the glow plug is dry, no fuel is reaching the engine. Try re-priming the engine, point #3 step 4. Again verify that the engine is receiving fuel.
- c) Is the engine very difficult to turn over, to the point that the electric starter is unable to turn the cone? If yes, you have successfully filled the engine and carburetor with fuel, do not force the starter as you can damage the starter and prematurely wear out the starting cone and ultimately the starting shaft will fail. First, disconnect the glow starter and pickup the helicopter and tip forwards and backwards with the muffler side down. This will drain the muffler of raw fuel. Next turn the cone until the half past the highest compression point, here the exhaust port will open and again drain through the muffler. Try to start again. Same problem, remove the glow plug and spin the engine (without) plug and any excess fuel will be expelled, replace glow plug and try again.

If the engine still doesn't start, contact an experience modeler to help you with starting the engine, the problem maybe very simple.

Basic Hovering

Hovering When all is set, ready and checked, attach your training gear/pod and start the engine.

- (1) Place the helicopter pointing into the wind and stand behind the model about 15' away.
- (2) Always watch the nose of the helicopter, move the rudder left and the nose will move left.
- (3) Start by increasing the throttle slowly until the helicopter rises 2-6 inches off the ground then set it back down.
- (4) Repeat this process until you become comfortable with the holding the model in the same spot for a few seconds then land it.

After some time at this you can increase the height slightly up to 1 foot (be very carefull not to get too high) as you are practising taking off and landing. This is the most basic but required skill for the beginner to learn.

Beyond Hovering

It cannot be stressed enough that mastering the hovering skill is crucial to becoming a good helicopter pilot. As you progress in your learning, always practise hovering until you are completely comfortable in holding the helicopter in any direction at any altitude. Perfecting hovering enables you to learn all the types and styles of helicopter flying, forward flight, loops and rolls, 3D (aerobatic flying) and anything you want to do with your Hawk helicopter as it can be set up for beginner through to expert. Lastly, have fun!!

Pre-Flight Checklist

1. After turning radio on, move each servo separately, looking for unusual or excessive movement.
2. Lubricate the main shaft above the swashplate and the pitch slider on the tail output shaft with oil.
3. Inspect the main and tail rotor grips for play or binding.
4. Turn the main gear in both directions to feel if a problem is developing in the drive train.
5. Check the glow plug and fuel lines for signs of wear.

PRE-FLIGHT CHECK UP & TRIM ADJUSTMENTS

All trim adjustments are to allow you to lift the helicopter straight up and can be made one click or detent at a time on the radio.

(1) **Collective & Throttle:** Slowly raise the throttle stick, the helicopter should lift off at half stick. If it tends not to lift off increase the hover pitch on the radio or increase the throttle trim. If the helicopter lifts off before mid stick decrease these settings.

(2) **Rudder:** When the helicopter is ready to take off, make a correction trim first then use the rudder stick to control the Left & Right. Note, now is a good time to make a final adjustment on the gyro, see gyro manual.

(3) **Elevator:** If at hover the helicopter tends to move forward, move the trim down, if it moves backward move the trim upwards Use the elevator stick to control the Forward & Backward.

(4) **Roll (Aileron):** If at hover the helicopter tends to move left, move the trim right, if the helicopter moves to the right move the trim left. Move the Aileron stick to control the slide of the helicopter to the Right & Left.

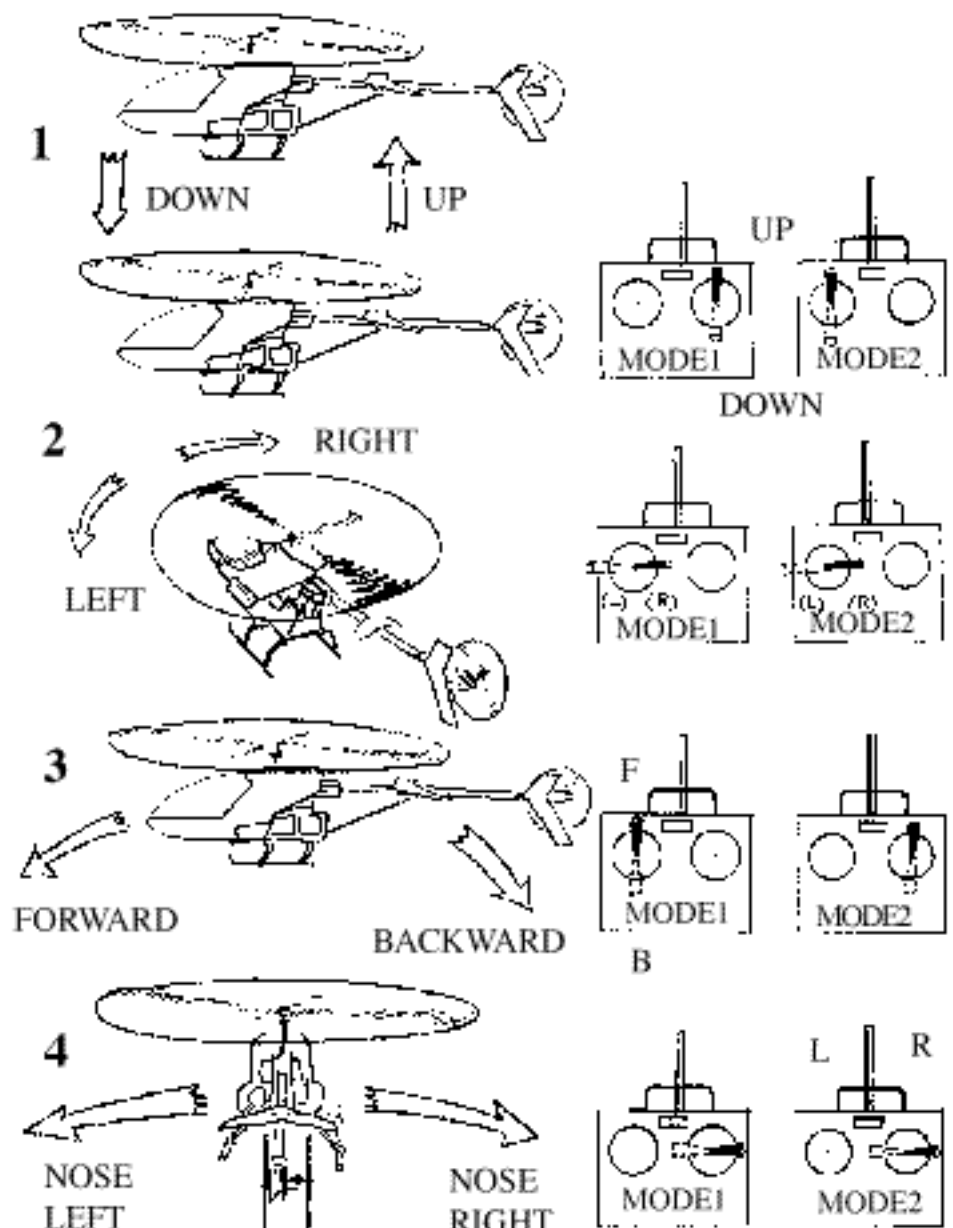

Bag 1			
		Feathering Shaft	1
		Dumper	2
		Bearing M6x13x5	4
Rotorhead Block	1	Bearing M6x12x4 Thrust	2
Offset Plate	2	M5 Locknut	2
Tie Bar	2	M2.5x30 Pin	2
Seesaw Shaft	1	M9x13x0.5 Flat Washer	4
Bearing Holder	2	M6x10x1 Flat Washer	2
Spacer M3x6x1.5	2	M4x12 Flat Washer	2
Ball Bearing M3x7x3	4	Flybar Control Arms	2
Ball Bearing M3x10x4	2	Steel Ball	2
M3x6 Self Tapping Screw	2	M2x10 Self Tapping Screw	2
M3x6 Phillips Mach Screw	2	Rod M2x15	4
Special Ball M3x6	2	Long Ball Link	4
		Short Ball Link	4
Washout Hub	1	M3x5 Set Screw	2
Washout Mixing Arms	2	Main Blade Grip	2
Ball Bearing M3x7x3	4	Bell Mixer	2
M3x5x0.5 Washer	2	Short Ball	2
M3x5x3 Spacer	2	Long Ball	2
Short Ball	2	M3x5x0.5 Washer	2
M3x16 Socket Cap Screw	2	M3x5x3 Spacer	2
M3x7 Flat Washer	2	M3x16 Socket Cap Screw	2
Swashplate	1	Flybar Paddles	2
Short Silver Ball	2	Flybar Weights	2
Medium Silver Ball	2	M3x4 Set Screw	2
Medium Black Ball	3		

Bag 3			
		Fuel Tank	1
		Fuel Line 97mm	1
		Long Vent Tube	1
Clutch Shoe	1	Short Pickup Tube	1
Clutch Bell Assembly	1	Rubber Stopper	1
Ball Bearing M12x18x3	2	Large Cap	1
Cooling Fan	1	Small Cap	1
Engine Mount	1	Clunk	1
M3x16 Socket Cap Screw	4	M2.5x18 Self Tapping Screw	1
M3x12 Socket Cap Screw	4	Cable Tie Wrap	1
M3x11 Flat Washer	4	Lower Left Sideframe	1
M5x13 Flat Washer	1	Lower Right Sideframe	1
M9x14 Flat Washer	1		

Bag 7			
		Large Bevel Gear	1
		Small Bevel Gear	1
Tail Rotor Blade	2	Tail Rotor Input Shaft	1
Tail Gearbox (R)	1	M2x12 Pin	2
Tail Gearbox (L)	1	M4x4 Set Screw	2
Horizontal Fin	1	M3x4 Set Screw	2
Vertical Fin	1	Bearing M5x13x4	2
Tail Rotor Grip	2	Bearing M5x11x4	2
Medium Steel Ball M3	2	Tail Output Shaft	1
Tail Rotor Hub	1	Spacer Tube	1
M3x4 Set Screw	1	M3x16 Socket Cap Screw	4
M3x20 Socket Cap Screw	4	M3x10 Socket Cap Screw	1
M3 Locknut	2	M3 Locknut	5
Ball Bearing M3x10x4	4		
Bearing M3x8x3 Thrust	2	Frame Strut Fitting	1
M3x5x0.5 Washer	8	Fin Strut Fitting	1
M5x10x1 Washer	2	Horizontal Fin Mount	1
M3x10x1.5 Plastic Washer	4	Drive Shaft Guide - Center	1
Pitch Slider Assembly	1	Drive Shaft Guide - End	2
M2x8 Pin	2	Pushrod Guide	3
Tail Pitch Ball Link	2	M3x30 Socket Cap Screw	2
Tail Pitch Bellcrank	1	M3 Locknut	2
M2.5x16 Phillips Mach Screw	1	M3x15 Self Tapping Screw	2
M5x2 Steel Ball	1	M3x12 Self Tapping Screw	3
Short Steel Ball M2z	1	M3x7 Flat Washer	1
Tube M3x8	1		

In Tailboom	
Tail Boom	1
Flybar	1
Tail Drive Shaft	1
Tail Drive Housing	1
Antenna Plastic Tube	1
Short Rudder Pushrod	1
Long Rudder Pushrod	1
Tailboom Strut	1

In Box	
Instruction Manual	1
Registration Card	1
Canopy	1
Windshield	1
Decal Sheet	1
Main Rotor Blades	1

Special Edition Bag Parts List

The bag parts list covers all parts common to both helicopter kits. The last section lists those parts different on the 46 SE.

Bag 2			
		Mast Stopper	1
Left Upper Sideframe	1	Bearing M10x19x5	1
Right Upper Sideframe	1	Bearing M8x19x6	1
Main Gear Assembly	1	M14x19x1 Washer	1
Main Shaft	1	M3x16 Socket Cap Screw	1
		M3x20 Socket Cap Screw	1
Tail Drive Bevel Gear	1	M4x4 Set Screw	2
Tail Trans. Output Shaft	1	Long Hex Spacer	2
Bearing M5x13x4	4	Short Hex Canopy Mount	2
E-ring	1	Canopy Thumb Screws	2
M3x4 Set Screw	2	M3x40 Threaded Stud	1
Counter Gear	1		
Alloy Drive Gear	1	Start Cone	1
Oilite Bearing M5x7x2	2	Start Shaft	1
Primary Drive Shaft	1	Collar M5x10x5	1
M2x12 Pin	1	M3x4 Set Screw	1
		Start Shaft Block Assembly	2
Elevator Lever Assembly	1	Spring	1
Roll Cyclic Bellcrank	2	M2x16 Pin	1
M3x10 Socket Cap Screw	4	M5x10 Flat Washer	1
Short Steel Ball M3	5	M3x12 Self Tapping Screw	8
Ball Bearing M6x10x3	2	M3x6 Washer Head Screw	1
Short Steel Ball M2	1		
M3x30 Socket Cap Screw	2	M3x35 Socket Cap Screw	4
Long Threaded Axle	1	M3 Locknut	4
Short Spacer	2	M3x7 Flat Washer	4
Ball Bearing M3x7x3	6	M3x12 Socket Cap Screw	4
M3x5x0.5 Washer	2	M2.3x25 Pushrod	2
M3x5x3 Spacer	2	Ball Links	4
Collective Shaft 6mm ø	1		
Collective Hex Spacer	1		
Collective Lever	1		
Collective Arm	2		

Bag 4			
Servo Mounting Tabs	4		
Pushrod Connector	1		
Special Ball Links	2		
		Fuel Line	1
Hex Key M1.5	1	Hex Key M2.0	1
Hex Key M2.5	1	Hex Key M2.5	1
Long Ball Link	15	Long Ball Link	15
Throttle Extension	1	Throttle Extension	1
Steel Ball w/2mm Thread	7	Steel Ball w/2mm Thread	7
M2 Hex Nut	16	M2 Hex Nut	16
		M4x30 Socket Cap Screw	2
		M4 Locknut	2
		M2.3x10 Servo Screw	20
		M3x25 Socket Cap Screw	5
		M3 Locknut	5
		M2x6 Self Tapping Screw	6
Rod - Aileron M2.3x128	2	Rod - Aileron M2.3x128	2
Rod - Elevator M2.3x105	1	Rod - Elevator M2.3x105	1
Rod - Coll/Swash M2.3x80	3	Rod - Coll/Swash M2.3x80	3
Rod - Throttle M2.3x75	1	Rod - Throttle M2.3x75	1

Bag 5			
Servo Tray Top	1	Servo Tray Top	1
Servo Side Tray	2	Servo Side Tray	2
Battery Tray	1	Battery Tray	1
Switch Mount	1	Switch Mount	1
Inside Canopy Mount	1	Inside Canopy Mount	1
Canopy Mount Hook	1	Canopy Mount Hook	1
Canopy Mount Spacer	1	Canopy Mount Spacer	1
M3x30 Phillips Mach Screw	2	M3x30 Phillips Mach Screw	2
M3x6 Self Tapping Screw	8	M3x6 Self Tapping Screw	8
M3x6 Washer Head Screw	2	M3x6 Washer Head Screw	2
M3x12 Self Tapping Screw	10	M3x12 Self Tapping Screw	10
M3x7 Flat Washer	2	M3x7 Flat Washer	2

Bag 6			
Landing Struts - Plastic	2	Landing Struts - Plastic	2
Landing Skids - Metal	2	Landing Skids - Metal	2
M3x9x4 Plastic Spacers	4	M3x9x4 Plastic Spacers	4
M3x4 Set Screws	4	M3x4 Set Screws	4
M3x16 Phillips Mach Screw	4	M3x16 Phillips Mach Screw	4
M3 Locknuts	4	M3 Locknuts	4

Falcon 46 SE Part Differences			
Spacer M4x6x2.5	2		
Ball Bearing M4x8x3	2		
		Vertical Anti-Rotation Bkt	1
M12x18x0.5 Steel Washer	1	Anti-rotation Base	1
M3x10 Socket Cap Screw	5	Slipper Auto Hub	1
M3 Locknut	5	O-Ring	1
M3x16 Socket Cap Screw	1	M4x5 Set Screw	2
M3x12 Plastic Tube	1	M12x18x0.28 Steel Washer	1

