

T-REX 450X

Preface

Thank you for buying ALIGN Products. The T-REX 450X Helicopter is designed as easy to use, full featured Helicopter R/C model capable of all forms of rotary flight. Please read the manual carefully before assembling the model, and follow all precautions and recommendations located within the manual. Be sure to retain the manual for future reference, routine maintenance, and tuning. The T-REX 450X is a new product developed by ALIGN. It features the best design available on the Micro-Heli market to date, providing flying stability for beginners, full aerobic capability for advanced fliers, and unsurpassed reliability for customer support.

IMPORTANT NOTES

R/C helicopters, including the T-REX 450X are not toys. R/C helicopters utilize various high-tech products and technologies to provide superior performance. The rotating blades on the model spin at high speed and can cause potential risk or injury if used improperly. It is mandatory that you observe all R/C safety rules and adhere to local laws as applicable. We recommend that you contact your local hobby store and inquire about safety, rules, regulations, and local laws and statutes regarding R/C model operation in your area. Please make sure to be conscious of your own personal safety and the safety of others and your environment when operating all ALIGN products. When used properly, ALIGN R/C products will provide years of R/C entertainment.

We recommend that you obtain the assistance of an experienced pilot before attempting to fly our products for the first time. A local expert is the best way to properly assemble, setup, and fly your model for the first time.

The T-REX 450X requires a certain degree of skill to operate, and is a consumer item. Any damage or dissatisfaction as a result of accidents or modifications are not covered by any warrantee and cannot be returned for repair or replacement. Please contact our distributors for free technical consultation and parts at discounted rates when you experience problems during operation or maintenance.

Note: Fly only in safe areas, away from other people. Do not operate R/C aircraft within the vicinity of homes or crowds of people. R/C aircraft are prone to accidents, failures, and crashes due to a variety of reasons including, lack of maintenance, pilot error, and radio interference. Pilots are responsible for their actions and damage or injury occurring during the operation or as of a result of R/C aircraft models.



It is not a Toy!

Safety notes

1. Locate an appropriate location:

R/C helicopters fly at high speed, thus posing a certain degree of potential danger. Choose an appropriate flying site consisting of flat, smooth ground, a clear open field, or a large open room, such as gymnasium or warehouse without obstacles. Do not fly near buildings, high voltage cables, or trees to ensure the safety of yourself, others, and your model. Do not fly your model in inclement weather, such as rain, wind, snow, or darkness.

**2. Obtain the assistance of an experienced pilot:**

Before turning on your model and transmitter, check to make sure no one else is operating on the same frequency. Frequency interference can cause your model, or other models to crash. The guidance provided by an experienced pilot will be invaluable for the assembly, tuning, trimming, and actual first flight.

3. Always be aware of the rotating blades:

During the operation of the helicopter, the main rotor and tail rotor will be spinning at a high rate of speed. The blades are capable of inflicting serious bodily injury and damage to the environment. Be conscious of your actions, and careful to keep your face, eyes, hands, and loose clothing away from the blades. Always fly the model a safe distance from yourself and others, as well as surrounding objects. Never take your eyes off the model or leave it unattended while it is turned on. Immediately turn off the model and transmitter when you have landed the model.

**PREVENT MOISTURE**

R/C models are composed of many precision electrical components.

It is critical to keep the model and associated equipment away from moisture and other contaminants.

The introduction or exposure to water or moisture in any form can cause the model to malfunction resulting in loss of use, or a crash.

Do not operate or expose to rain or moisture.

**KEEP AWAY FROM HEAT**

R/C models are made up various forms of plastic.

Plastic is very susceptible to damage or deformation due to heat.

Make sure not to store the model near any source of heat such as an oven, or heater.

It is best to store the model indoors, in a climate-controlled, room temperature environment.



[Back](#) [Next](#)

Features/Equipments to be prepared

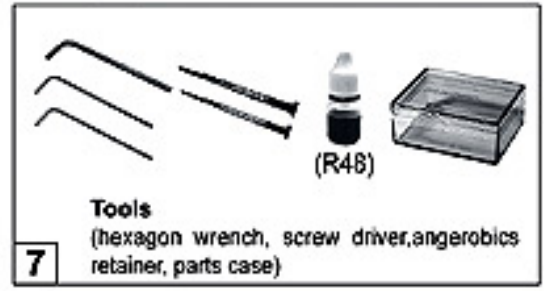
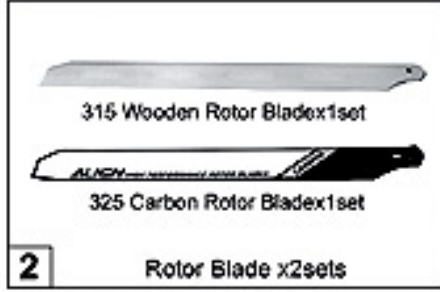

Radio transmitter and electronic equipment required for assembly

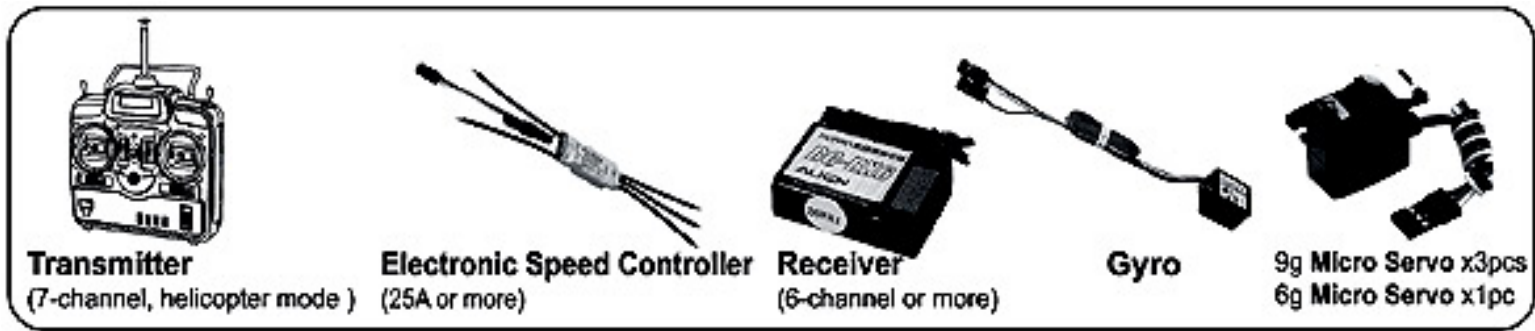

Power system to be prepared



Tools to be prepared



[Back](#) [Next](#)

Main rotor installation

Each section of the manual has its associated parts bag. Each bag is labeled accordingly. Make sure to only open the bags as indicated in the instructed manual and place them into the provided parts cases. Do not open all the bags at once, or out of order to avoid confusion and difficulty assembling the model.

Start assembling the model by beginning with the main rotor head. We will build the model from the rotor head, out to the rest of the model. Apply silicon lubricant in the inside and outer edges of the o-rings, then insert them into the main rotor head. The flybar ends must be the same length on each side of the rotor head. Measure the distance between the edge of the flybar paddle and the flybar control arm; make this distance the same on both sides. The flybar control arms must be parallel to each other. The flybar paddles must be locked in the same position, exactly horizontally level with the swashplate. Use an angle of attack ruler on each flybar paddle and adjust the angles so that they are the same, and have the correct angle. It may become necessary to apply some glue on the screws to properly tighten them. The screws must be tightened snugly, but be careful to not overtighten them as it will strip the threads and cause the assembly to become loose.

Note: After tightening the flybar control arms and paddles, check for free movement and minimal gaps between the surfaces. All rotor head assemblies should be assembled tightly snug, without any binding or slow movement.

Parts kit No. HH

No.	PN.	Parts No.	Description	QTY	Specification	No.	PN.	Parts No.	Description	QTY	Specification
2	HH2	HH2002	Main rotor housing	1		24	HH4	HH4006	Linkage ball	4	∅4.75
3	HH2	HH2003	Pin	2	∅1.5X17.8	25	HH4	HS4001-1	Cross screw	4	M2X6.5
4	HH2	HH2004	O-Ring	2	∅3X5.5X2	26	HH4	HS2001	Screw	2	M2X8
5	HH2	HH2005	collar	2	∅3X∅5X4mm	27	HH4	HS6001	Collar screw	2	M2
6	HH2	HH2006-1	Main rotor holder	2	∅8.2X38mm	29	HH4	HH4007A	Flybar control arm	2	
7	HH2	H693ZZ	Bearing 693zz	4	3X8X4mm	30	HH4	HH4007B-1	Flybar arm bushing	2	∅2mm
8	HH2	HH2007	Feathering shaft	1	∅3X40mm	31	HH4	HS5001	Set screw	2	M3X3
9	HH2	HS8001	Washer 2x5x0.4	2	M2	32	HH4	HH4006	Linkage ball	2	∅4.75
10	HH2	HS3001	Socket screw	2	M2X5	33	HH4	HS4001-1	Cross screw	2	M2X6.5
19	HH4	HH4002	Flybar seesaw holder	1	36X14.6X6mm	220	HH5	HH4008	Collar	2	∅3X2.1
20	HH4	HH4003	Flybar rod	1		221	HH4	K10012	Washer	2	∅2.3
22	HH4	HH4005A-1	SF mixing lever	2	36.45X4.5mm	222	HH2	HH4006	Linkage ball	2	∅4.75
23	HH4	HMR52ZZ	Bearing MR52zz	2	2X5X2.5mm	223	HH2	HS4001-1	Cross screw	2	M2X6.5

When you see the marks as below, please use glue or oil to ensure flying safety.

CA: Use Cyanoacrylate Adhesive to fix.

R48: Use anaerobics retainer to fix.

OIL: Add lubricant

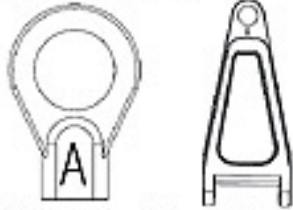

When assembling ball links, make sure the "A" character faces outside.

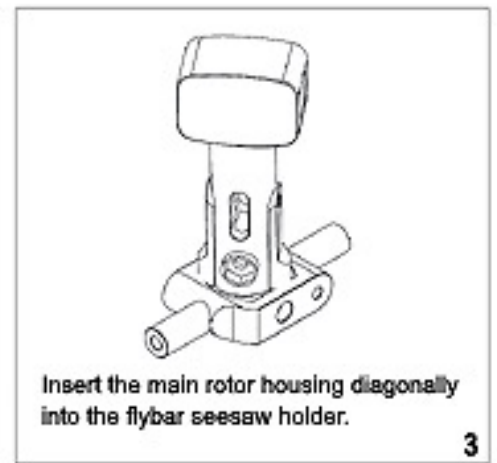
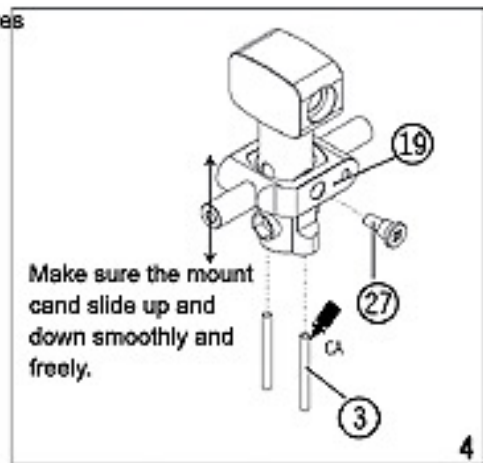
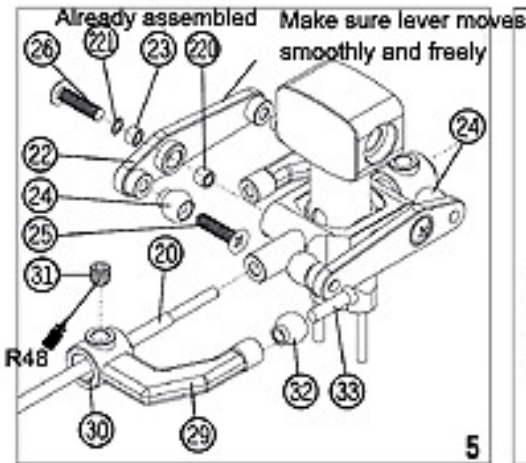
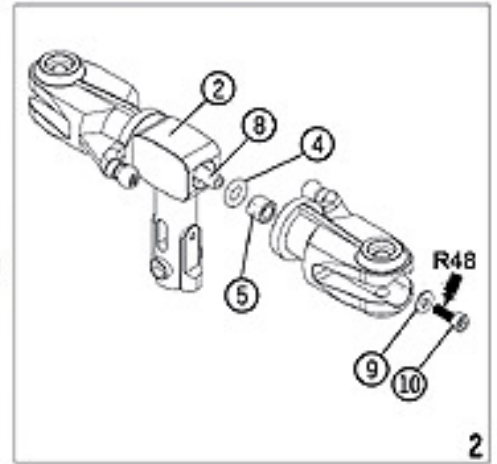
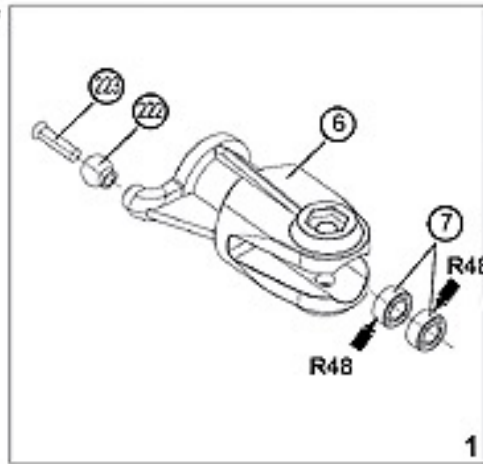

Parts kit No. HH

No.	PN.	Parts No.	Description	QTY	Specification	No.	PN.	Parts No.	Description	QTY	Specification
11	HH2	HS2003	Screw	1	M2X12	40	HH5	HH4006	Linkage ball	2	ø4.75
12	HH2	HS7001	Nut	1	M2	41	HH5	HS4001-1	Cross screw	2	M2X6.5
14	HH3	HH3002	Main rotor blade	2	295mm	42	HH5	HS2001	Screw	2	M2X8
15	HH3	HH3003	Blade collar	2	ø3	220	HH5	HH4008	Collar	2	ø3X2.1
16	HH3	HS3002	Socket screw	2	M3X16	221	HH5	K10012	Washer	4	ø2.3
17	HH3	HS7002	Nut	2	M3	43	HH5	HH5004A-1	Swashplate assembly		ø26X12.5
21	HH4	HH4004	Flybar paddle	2		49	HH5	HH4006	Linkage ball	8	ø4.75
35	HH5	HH5002	Washout base	1	ø5X10	50	HH5	HS4001-1	Cross screw	8	M2X6.5
36	HH5	HH5003A	Flybar control lever	2		52	HH6	HH6002-1	Main shaft	1	ø5X116
37	HH5	HH5003B	Washout linkage	2		53	HH6	HH6003	Main shaft lock ring	1	ø5X6
38	HH5	HH5003C-1	Pin	2	ø1.1X7	54	HH6	HS5001	Set screw	1	M3X3
39	HH5	HMR52ZZ	Bearing MR52zz	2	2X5X2.5mm						

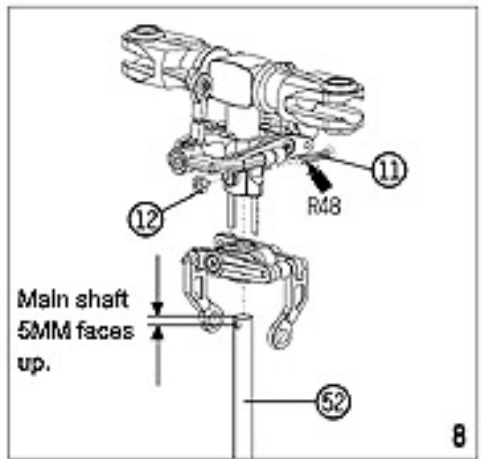
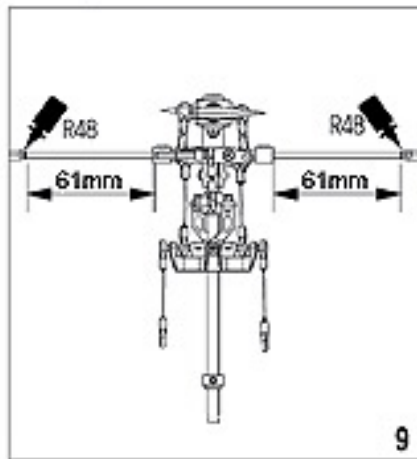
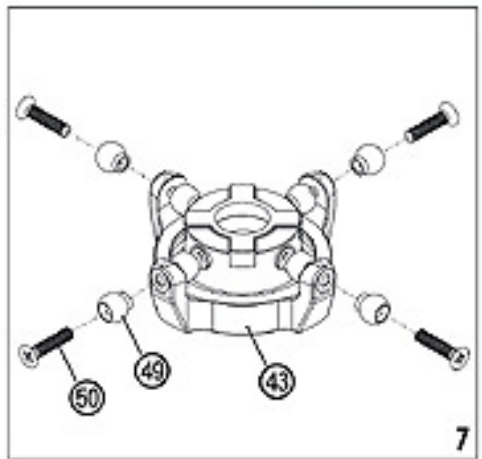
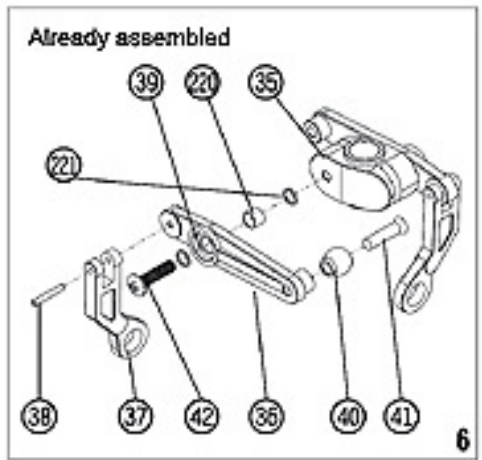
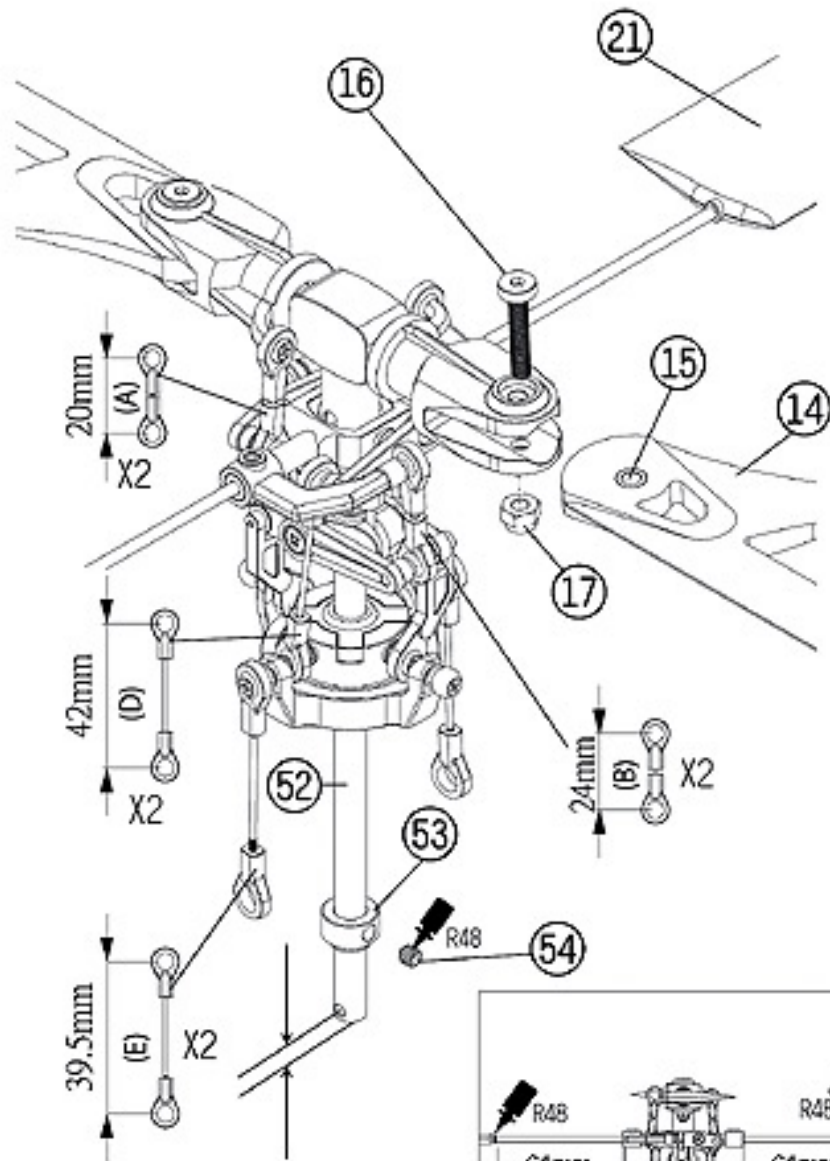

Parts kit No. HB-HF

No.	PN.	Parts No.	Description	QTY	Specification	No.	PN.	Parts No.	Description	QTY	Specification
95	HB6	HB6001A-1	Main drive gear	1	150T	160	HF2	HF2002-1	Landing skid	2	
98	HB6	HF0612	One way bearing	1	$\varnothing 6 \times 10 \times 12 \text{mm}$	161	HF2	HF2003	Skid pipe	2	Aluminum
99	HB6	HB6002	One way bearing shaft	1	$\varnothing 6 \times 21.5$	162	HF2	HF2004	Skid pipe end cap	4	$\varnothing 4.5 \times 5.75$
100	HB6	HB6003	Shaft ring	1	$\varnothing 6 \times 1.5$	224	HF2	HF2007	Antenna pipe	1	$\varnothing 3 \times 300 \text{mm}$
101	HB6	HB6001B-1	Autrotation tail drive gear	1	109T	225	HF2	K10181	Landing skid nut	4	$\varnothing 5.3 \times 10$

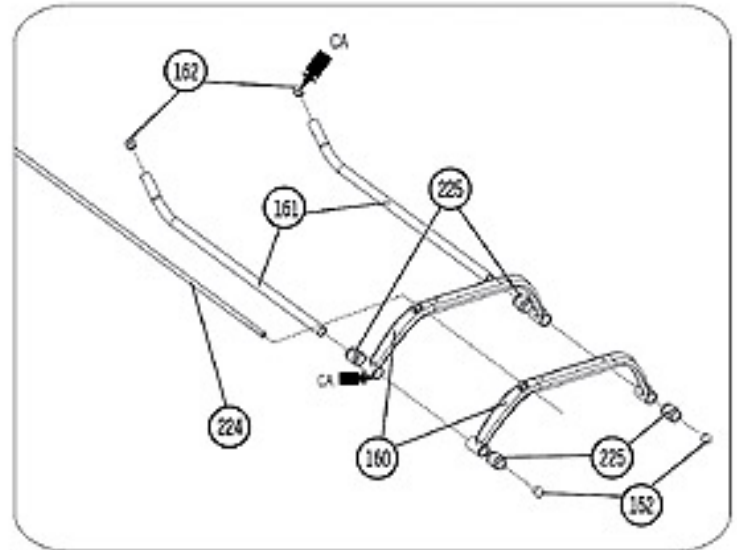
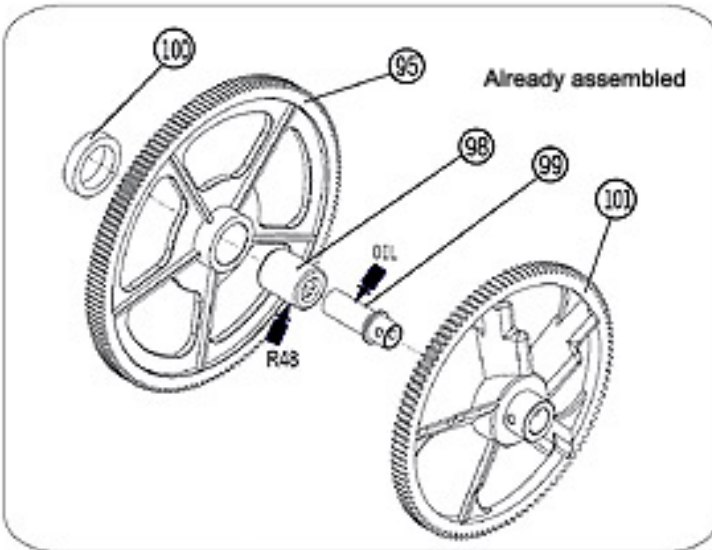

LINKAGE ROD

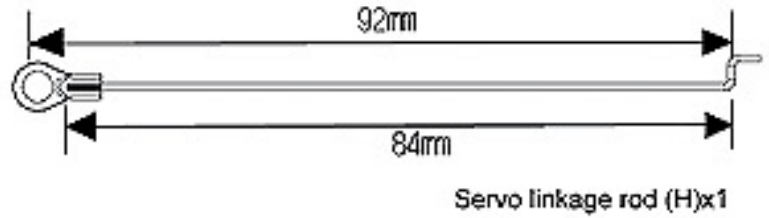
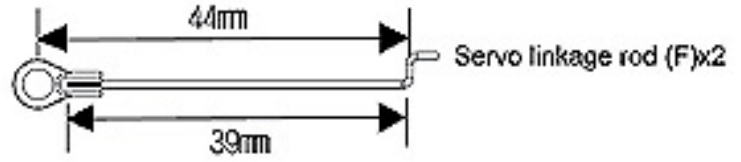
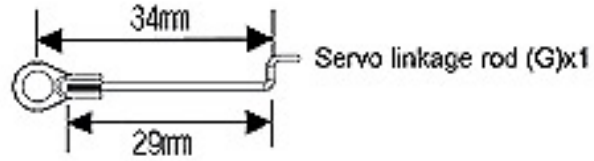
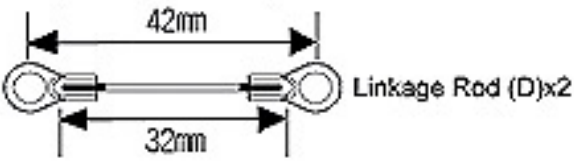
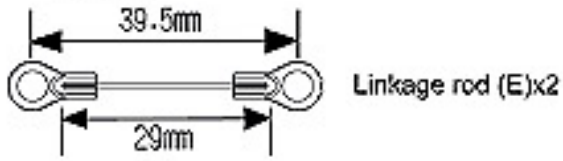
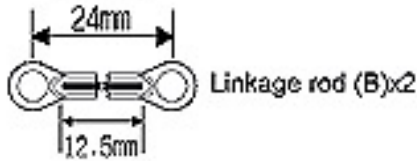
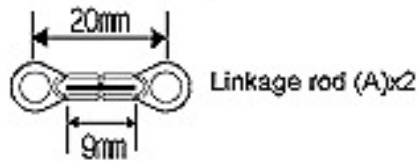

SCREW SPECIFICATION

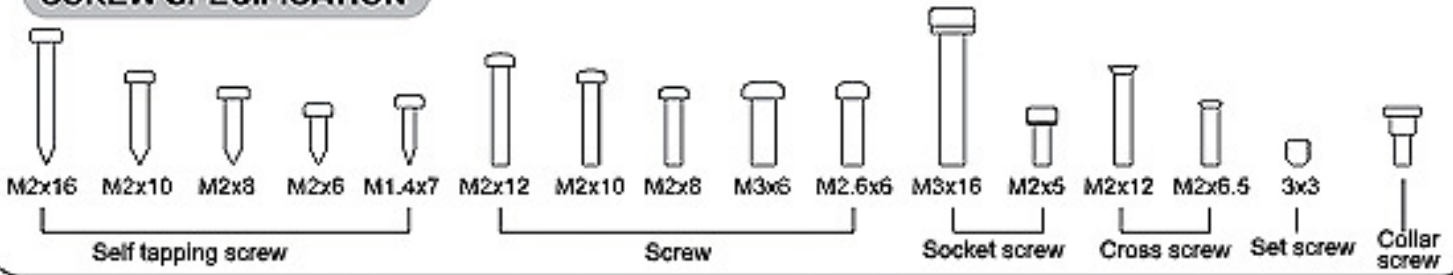

[Back](#) [Next](#)

Main frame set and power system(1)

The screws must be firmly tightened, but not over tightened, or they will strip and become loose. Use "Blue" Loctite or Threadlock where screws are tightened into metal objects.

Parts kit No. HB·HF

No.	PN.	Parts No.	Description	QTY	Specification	No.	PN.	Parts No.	Description	QTY	Specification
56	HB2	HB2002-1	Main frame (L)	1		66	HB3	HB3001B	Tail drive pulley	1	11T
57	HB2	HB2003-1	Main frame (R)	1		67	HB3	HMR83ZZ	Bearing MR83ZZ	2	3X8X3mm
58	HB2	HB2004-1	Servo frame	1		68	HB3	HB3001C-1	Tail drive gear shaft	1	$\varnothing 2.9 \times 27$
59	HB2	HB2005	Frame spacer	1	$\varnothing 4.5 \times 20$	69	HB3	HB3001D-1	Tail drive gear	1	22T
60	HB2	HB2006	Canopy spacer	2	$\varnothing 4 \times 24.5$	71	HB4	HB4001A	Elevator control arm link	2	19X39.5mm
61	HB2	H685ZZ	Bearing 685zz	2	5X11X5mm	72	HB4	HB4001C	Elevator control arm link pin	2	$\varnothing 1.5 \times 19$
62	HB2	HS1003	Self tapping screw	20	M2X8($\varnothing 3.4$ head)	73	HB4	HB4001B	Elevator control arm	1	24.3X44.5mm
63	HB2	HS1002	Self tapping screw	2	M2X6	77	HB4	HS2004	Screw	2	M2.6X6
64	HB3	HB3001-1	Tail drive gear assembly			79	HB4	HS8002	Washer	2	M2.6
65	HB3	HB3001A	Cover	1	$\varnothing 8 \times \varnothing 4.3 \times 2.75$	163	HF2	HS1002	Self tapping screw	4	M2X6

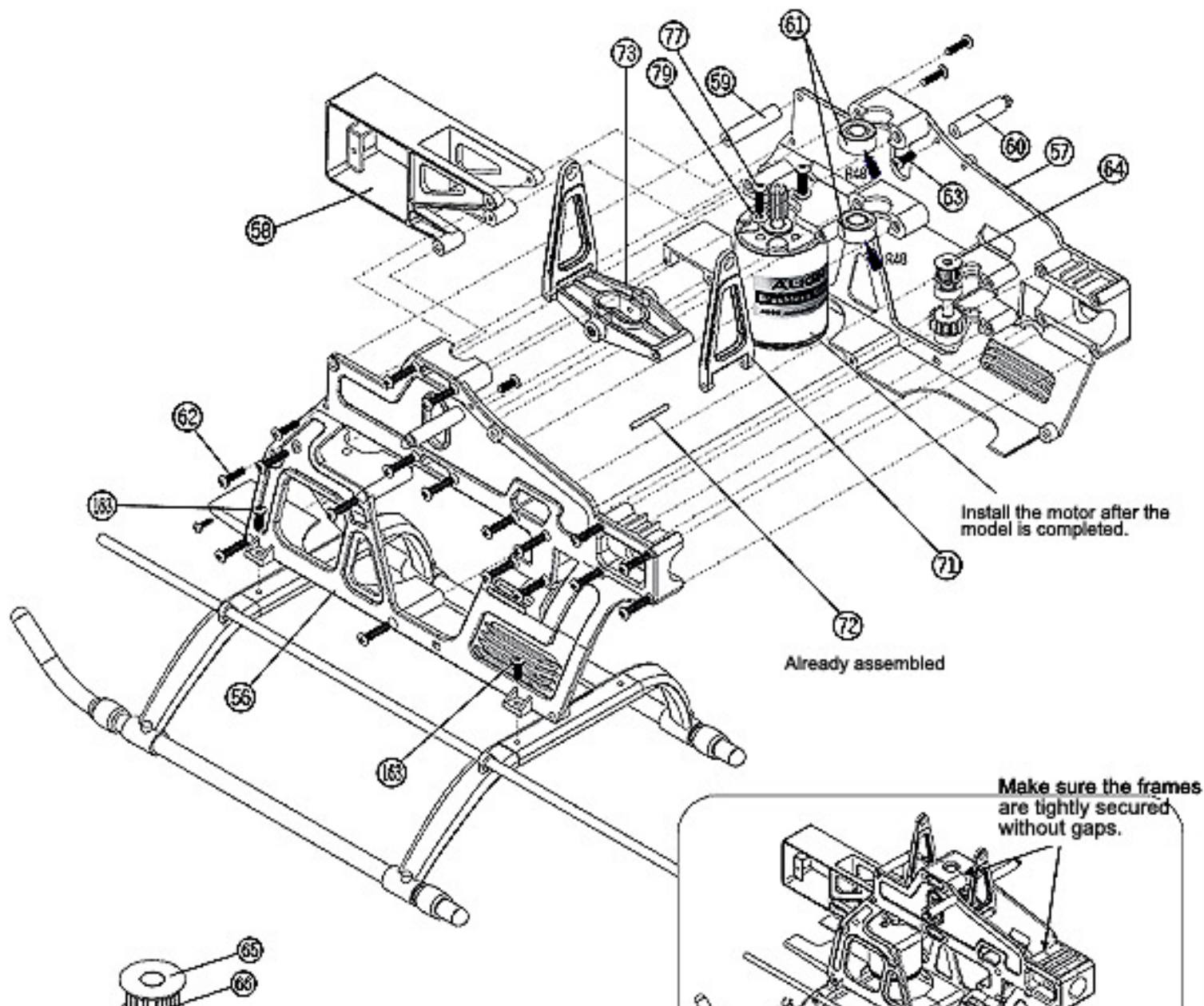

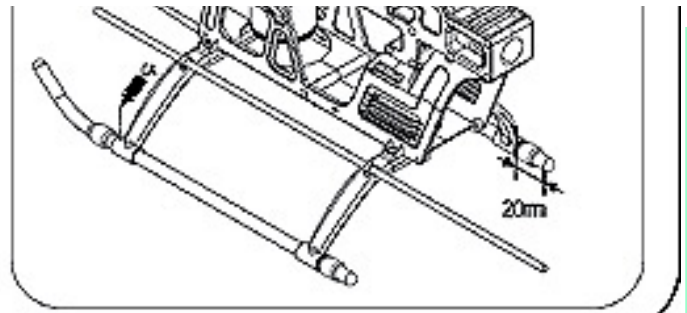
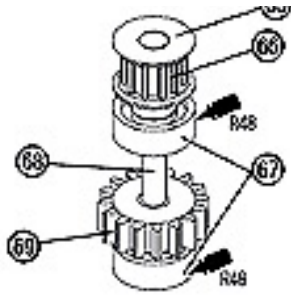

[Back](#) [Next](#)

Main Frame installation(II)

The screws must be firmly tightened, but not over tightened, or they will strip and become loose. Use "Blue" Loctite or Threadlock where screws are tightened into metal objects.

Parts kit No. HB

No.	PN.	Parts No.	Description	Q'TY	Specification	No.	PN.	Parts No.	Description	Q'TY	Specification
74	HB4	HB4003	Elevator control arm shaft	1	∅2X8.5	88	HB5	HB5004	Lever collar	2	3X8.1mm
75	HB4	HB4004	Elevator arm lever	1		89	HB5	HH4006	Linkage ball	5	
76	HB4	HS4002	Screw	2	M2X12	90	HB5	HS4001-1	Cross screw	5	M2X6.5
81	HB4	HH4006	Linkage ball	1	∅4.75	91	HB5	HB5005	Control arm collar	2	∅5
82	HB5	HS4001-1	Cross screw	1	M2X6.5	92	HB5	HS2001	Screw	2	M2X8
84	HB5	HB5001A	Collective pitch control arm	1		93	HB5	HS2003	Screw	2	M2X12
85	HB5	HMR63ZZ	Bearing MR63zz	2	3X6X2.5mm	102	HB6	HS2003	Screw	1	M2X12
86	HB5	HH4008	Bearing collar	2	∅3X2.1	103	HB6	HS7001	Nut	1	M2
87	HB5	HB5003	Aileron control lever	2	∅3X2.5	221	HB5	K10012	Washer	2	∅2.3

Cut surplus to avoid scraping outer covering.

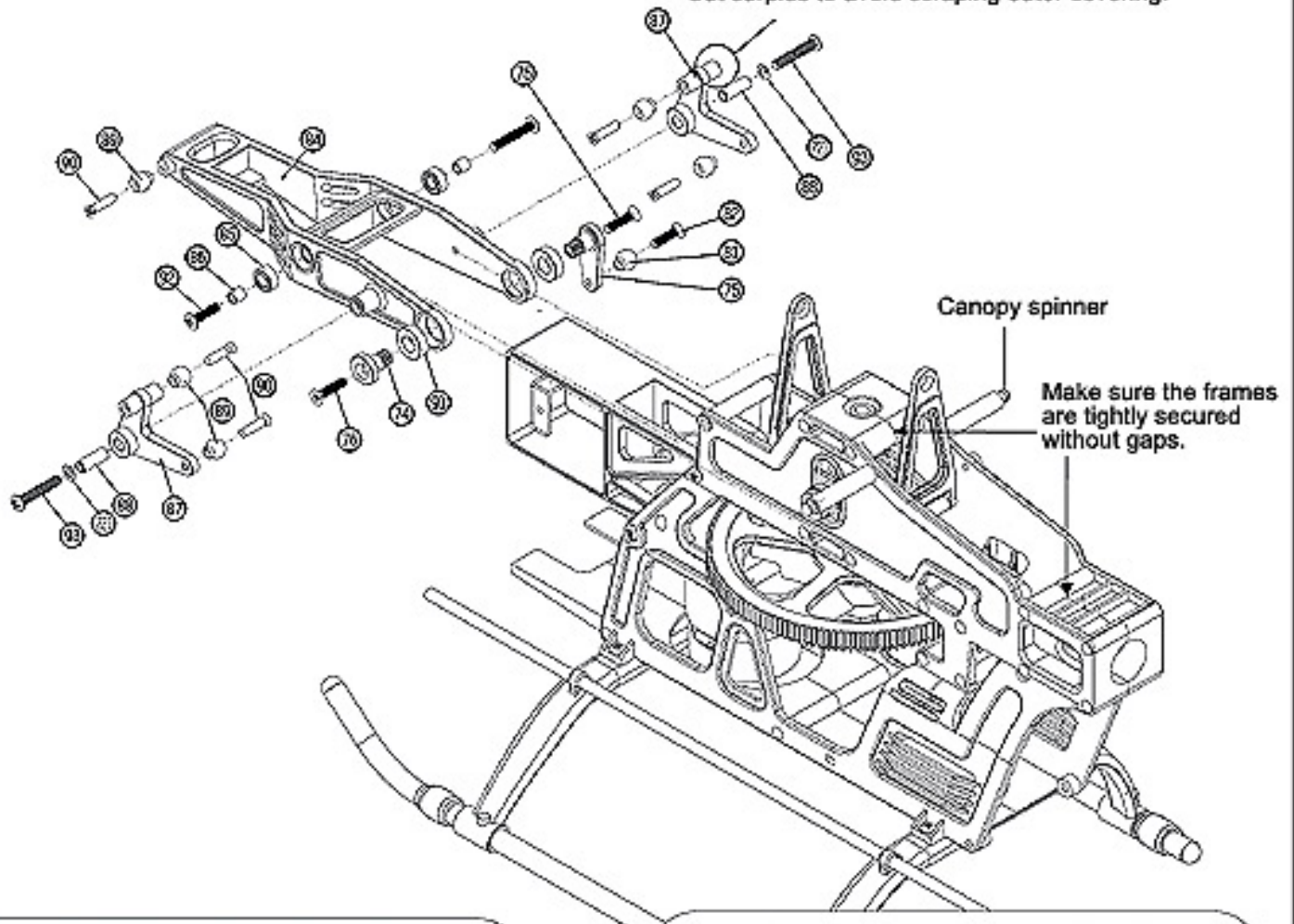

Main rotor installation:
Put main shaft through the bearing and gear.
Fix it by M2x12 screw and nut.

Link together

Link together

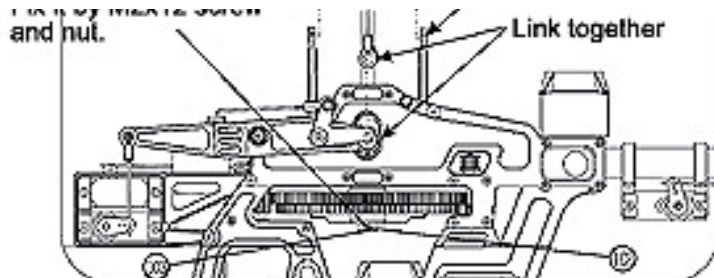
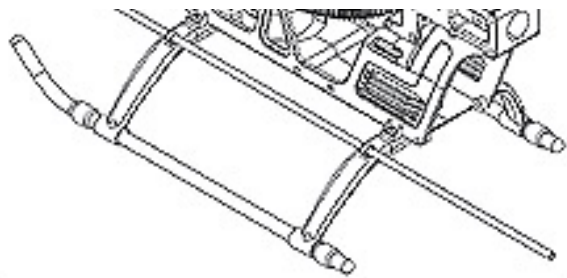

[Back](#) [Next](#)

Tail rotor system installation

Follow the instructions carefully and in order. Look for key points on each procedure.

1. The set screw on the tail rotor housing must point towards the tail rotor blades and be tightened firmly.
2. When assembling the tail boom and fuselage, make sure to turn the belt 90 degrees as illustrated in the diagram 10. Mount the belt around the drive pulley, mount the other half of the tail case and tighten it, leaving it loose enough to rotate on the boom with some effort. Adjust belt tension by moving the tail case further back on the boom. Once the belt has the proper tension, make sure the tail rotor blades are perpendicular to the ground when looking at the helicopter from behind. Tighten the screws to lock into this position. Check often and re-adjust as needed.

Parts kit No. HT

No.	PN.	Parts No.	Description	Q'TY	Specification	No.	PN.	Parts No.	Description	Q'TY	Specification
109	HT1	HT1001	Tail rotor drive belt	1	371T	132	HT4	HS2002	Screw	1	M2X10
110	HT2	HT2001	Tail boom	1	∅12X322	133	HT4	HS1004	Self tapping screw	3	M2X10
116	HT3	HT3001	Vertical stabilizer	1	2X125mm	134	HT5	HT5001-1	Tail rotor shaft assembly	1	∅3
120	HT3	HS1005	Self tapping screw	2	M2X16	138	HT6	HT6001	Tail rotor hub	1	∅3.55X13.2
121	HT4	HT4001	Tail unit housing (R)	1	R6X46.5mm	139	HT6	HS5001	Set screw	1	M3X3
122	HT4	HT4002	Tail unit housing (L)	1	R6X46.5mm	140	HT6	HT6002A-1	Tail rotor housing	2	∅5X16
123	HT4	HMR83ZZ	Bearing MR83ZZ	2	3X8X3mm	141	HT6	HMR52ZZ	Bearing MR52zz	2	2X5X2.5mm
124	HT4	HT4003	Tail pulley assembly	1	∅8X5	142	HT6	HT6003-1	Tail rotor blade	2	2X60mm
127	HT4	HT4004	Tail rotor control arm	1	∅3X5.5	143	HT6	HS3001	Socket screw	2	M2X5
128	HT4	HT4005	Tail pitch control lever	1	∅2X∅3X5.5	144	HH4	HS2001	Screw	2	M2X8
129	HT4	HH4006	Linkage ball	1	∅4.75	145	HT7	HT7001	Tail rotor control set		
130	HT4	HS4001-1	Cross screw	1	M2X6.5	146	HT7	HT7001A	Ball link (short)	2	∅4.75X10.5
131	HT4	HS2001	Screw	1	M2X8	147	HT7	HS1001	Self tapping screw	2	M1.4X7

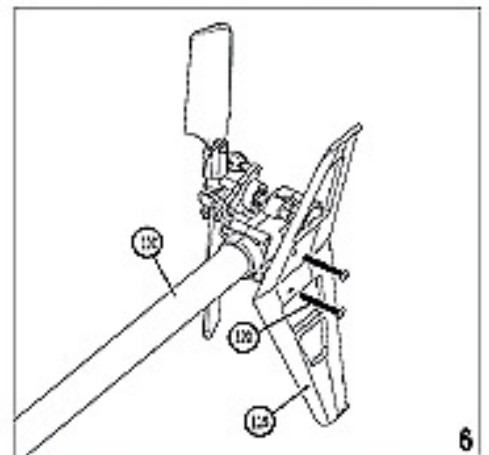
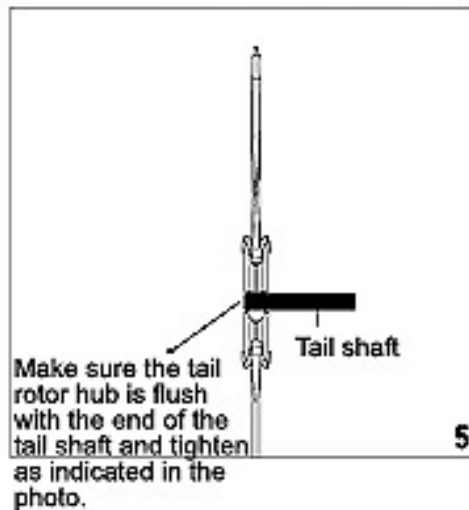
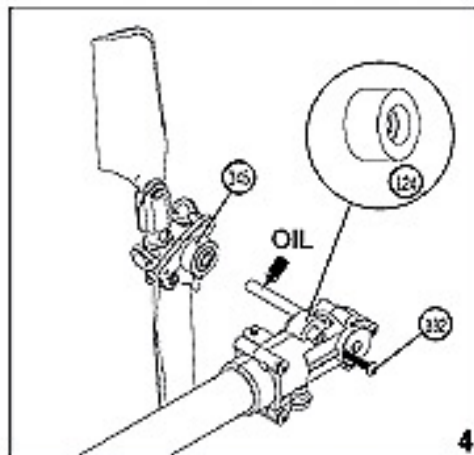
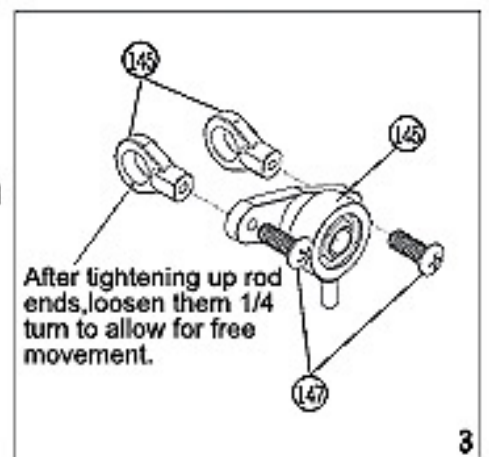
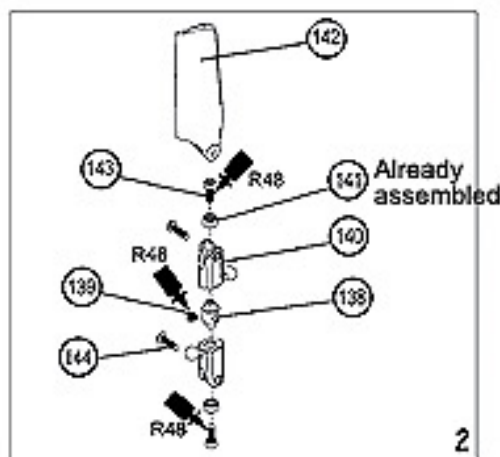
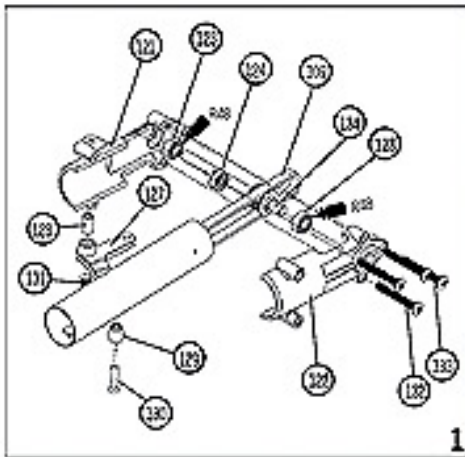

Parts kit No. HT

No.	PN.	Parts No.	Description	Q'TY	Specification	No.	PN.	Parts No.	Description	Q'TY	Specification
155	HT9	HT9001A-1	Tail linkage rod	1	∅2X250mm	114	HT2	HS1002	Self tapping screw	4	M2X6
156	HT9	HT9001C	L-type linkage rod	1	∅1.3X16mm	115	HT2	HS1003	Self tapping screw	2	M2X8(∅3.4head)
157	HT9	HT9001B	Linkage rod(B)	1	∅1.3X12.5mm	116	HT3	HT3001	Vertical stabilizer	1	
158	HT9	HT7001A	Ball link (short)	1		117	HT3	HT3002	Horizontal stabilizer	1	
111	HT2	HT2002	Tail servo mount	2		118	HT3	HT3003	Bracket	1	
112	HT2	HT2003A	Tail boom brace terminal	4		119	HT3	HS1002	Screw	2	M2X6
113	HT2	HT2003B	Tail boom brace	2	∅3X205mm						

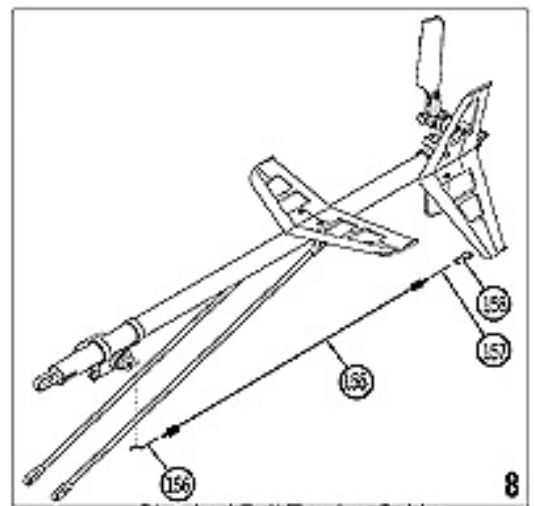
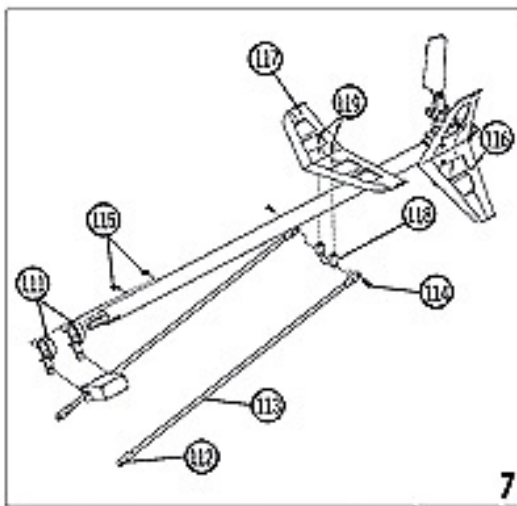

Standard Belt Tension Guide:
 Visualize a straight line through the center of the main drive gear. You should be able to apply light tension to the belt with your finger until it reaches a point 3/4 of the way to the opposite edge of the main gear, or 1/4 of the way past the virtual center of the main gear. Refer to photo.
 (slightly looser belt tension will provide slightly more power.)

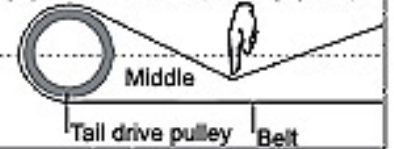

After tail set is completed, wedge tail linkage rod in the bottom of the bracket.

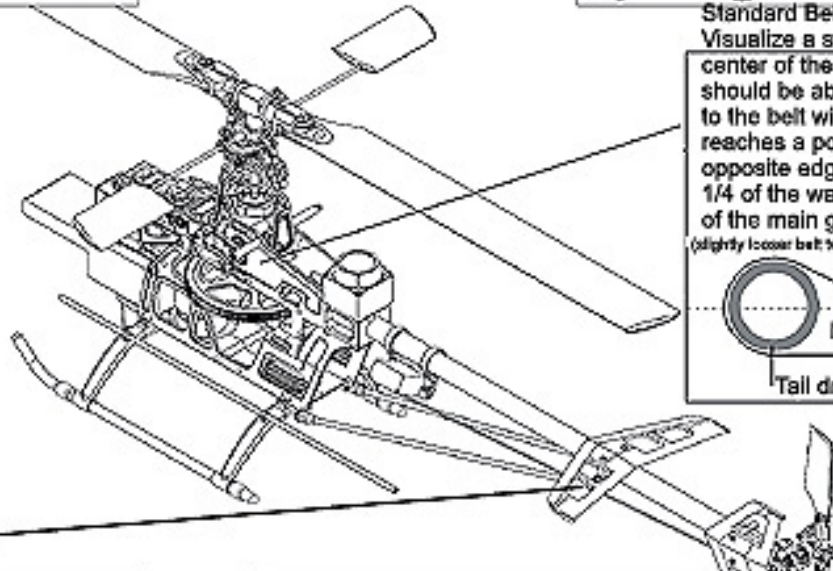

If the tail does not rotate counter-clockwise, you rotated it the wrong way. Re-assemble following the instructions.

Rotate the belt 90 degrees as illustrated in the photo before mounting on tail drive pulley.

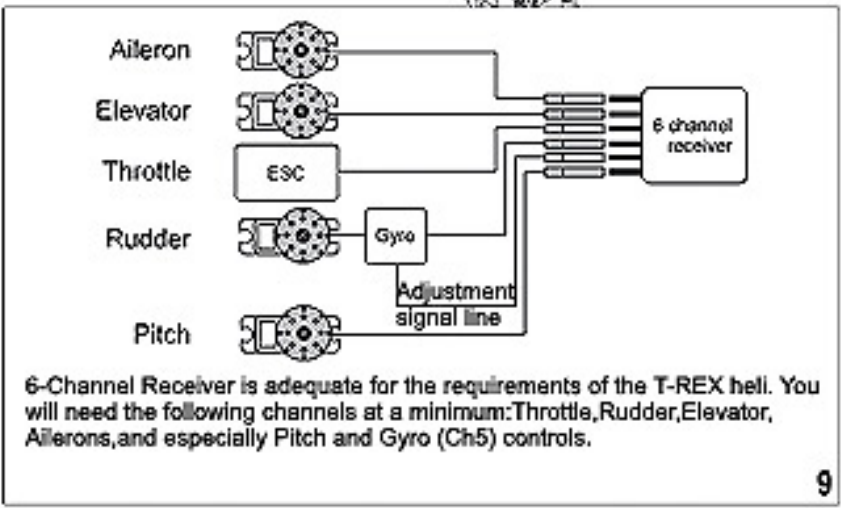
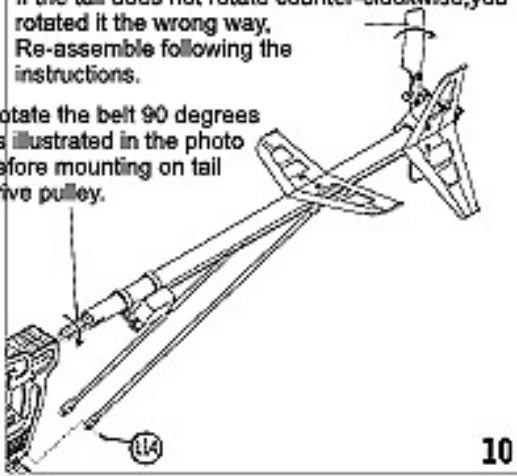

6-Channel Receiver is adequate for the requirements of the T-REX heli. You will need the following channels at a minimum: Throttle, Rudder, Elevator, Ailerons, and especially Pitch and Gyro (Ch5) controls.

[Back](#) [Next](#)

Assembling steps

PARTS AND EQUIPMENT ASSEMBLY ILLUSTRATION

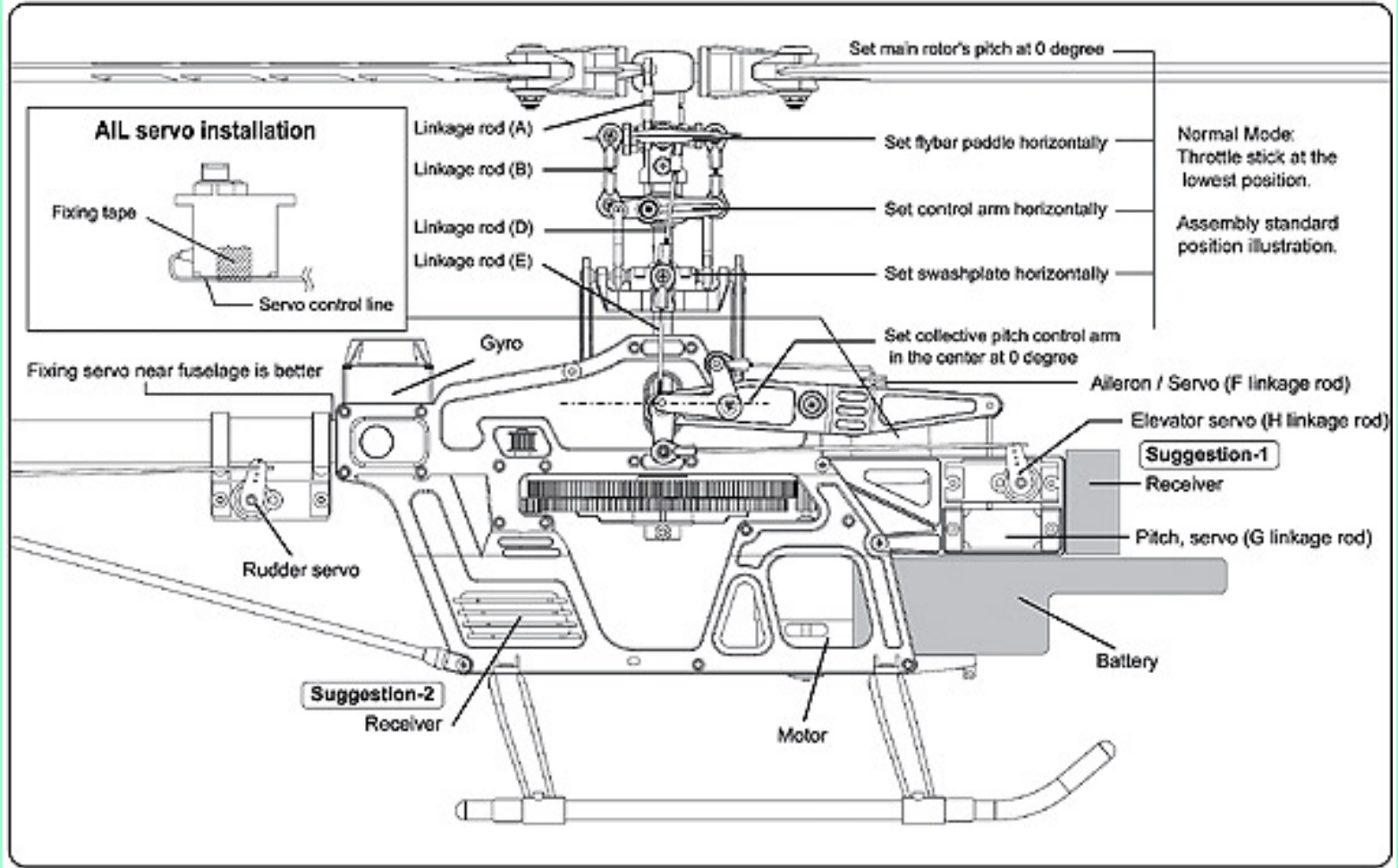

FINAL PRE-FLIGHT ADJUSTMENTS

1. Pitch range: 21°

Note 2. If the pitch is set too high, it will result in shorter flight duration and poor motor performance.

3. Setting the throttle to provide a higher speed is preferable to increasing the pitch too high.

Hovering Flight

3D Flight

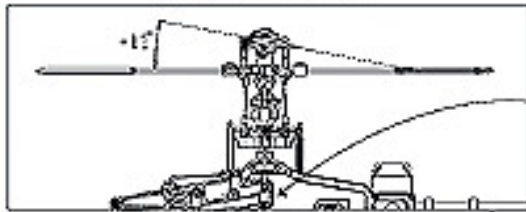

Stick position at high/Throttle 100%/Pitch +11°

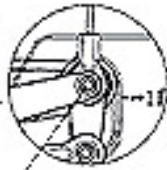

Set at high position.

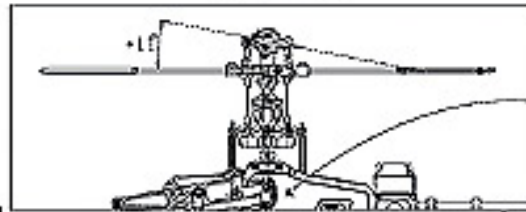

Stick position at high/Throttle 100%/Pitch +11°

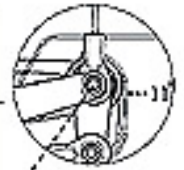

Set at high position.

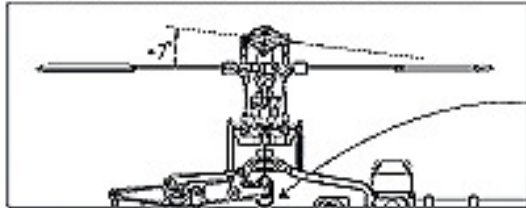

Stick position at middle(Hovering)/Throttle 70%/Pitch +7°



Set at upper-middle position.

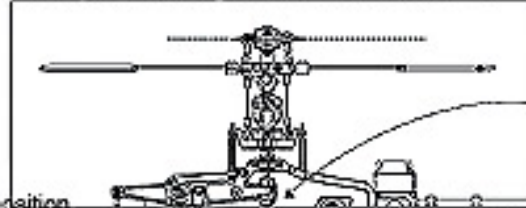

Stick position at middle/Throttle 80%/Pitch 0°

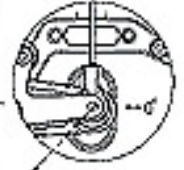

Set at middle position.

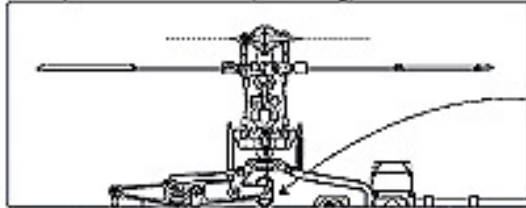

Stick position at low/Throttle 0%/Pitch 0°



Set at middle position.

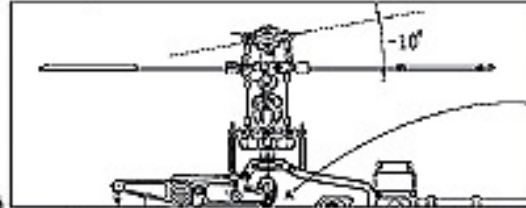

Stick position at low/Throttle 100%/Pitch -10°



Set at low position.

Throttle	Pitch
5 100% High speed	+8° ~ +11°
4 85%	
3 70% Middle speed (hovering)	+5° ~ +7°
2 45%	
1 0% Low speed	0°



Throttle Curve (Hovering Flight)

Throttle	Pitch
5 100%	+8° ~ +11°
4 85%	
3 75%	+7°
2 50%	
1 50%	-4°

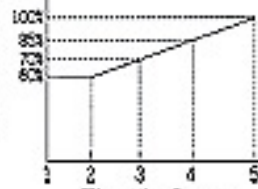

Throttle Curve (Simple Aerobatic Flight)

Throttle	Pitch
3 100% High speed	+8° ~ +11°
2 85% Middle speed	0°
1 100% Low speed	+5° ~ -10°



Throttle Curve (3D Flight)

[Back](#) [Next](#)

Pre-flight checklist

This model helicopter is an electronically controlled mechanical device traveling at high speeds and altitudes, with high-speed rotating blades posing a potential dangerous risk. Please make it a habit to always perform a pre-flight check of the entire model prior to each flight. If you discover any broken, loose, or worn parts, don't fly the model. Repair or replace items immediately. After each flight, completely clean the model and check for damage or wear. Following these simple steps will provide for maximum enjoyment owning and operating the T-REX Helicopter.

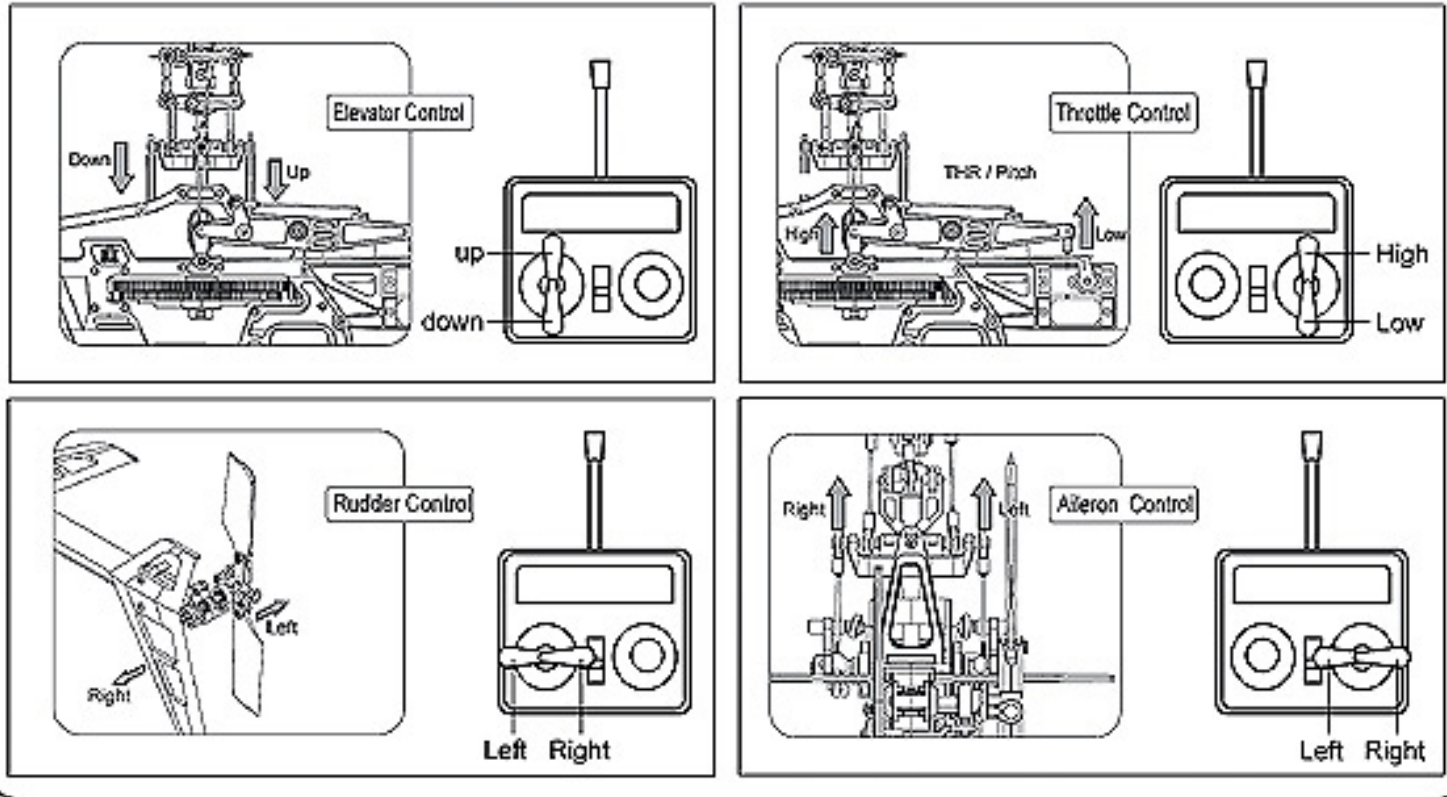

Main rotor adjustment

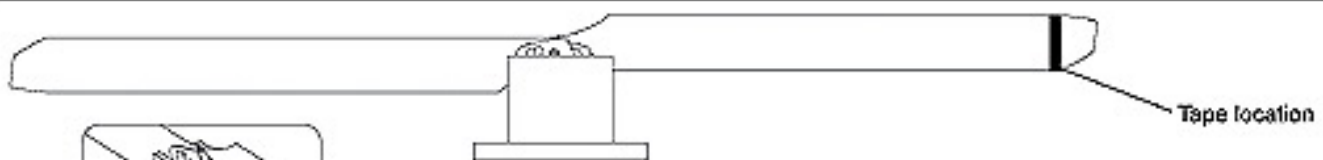

★ Before fling, balancing of the blades is very important. Screw the rotor blades together as illustration. The rotor blade are properly balanced when they are suspended exactly horizontally. If not, the blades are not in equilibrium. This is corrected by applying tape to lighter blade.

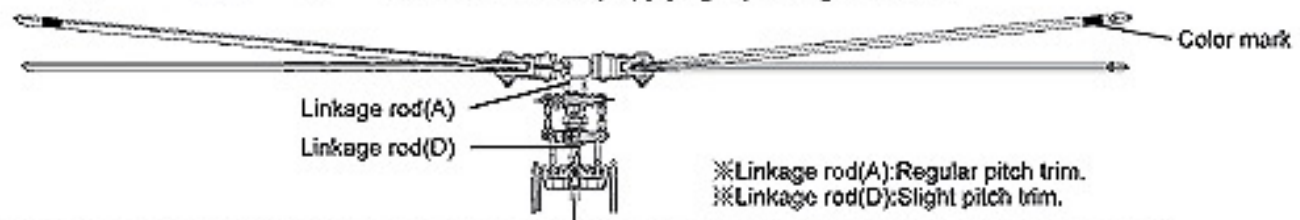

- ★ Apply a red piece of tape on one blade, or paint a red stripe with a marker or paint to identify one blade.
- ★ Run the helicopter at a safe distance and have someone look at the spinning blades at the reference angle shown in the photo. If the blade tracking is not set correctly, you will be able to identify the blade with the red identifying mark rotating higher or lower than the other blade. Adjust the linkage rod length shorter or longer to make both blades track level.

Troubleshooting the power system

Please check the followings when the power or speed gets abnormally slow:

1. Check the battery is the correct specification for the helicopter and is fully charged.
2. Check if the pitch setting is too high.
3. Check the tightness of the main rotor blades. Blades should be tightened so that they do not move freely, but can be moved by applying slight pressure by hand.
4. Check for vibration on the main and tail rotors (vibration can be caused by main shaft wear, damage, or loosenes, check all linkages and bearings for excess play or wear).
5. Check for interference caused by improper gear mesh or belt tension.

[Back](#) [Next](#)

Regular maintenance

Regular maintenance is required to keep the T-REX 450X helicopter in optimal and safe flying condition. The model requires precise configuration of the components and settings to be kept by the owner. Maintain regular maintenance on the model to avoid accidents or loss, and optimum performance.

MAIN ROTOR CHECKLIST

1. **Main Rotor Housing:** When the main rotor housing is worn or faulty, there will be obvious vibration and poor flight control. Check the main rotor, main shaft, and feathering shaft for wear or deformity. Replace parts as necessary to eliminate imbalance.
2. **O-Rings:** The O-Rings will lose their elasticity over time. This will cause excess play on rotor and cause instability. Replace as needed.
3. **Main Rotor Holder:** When the heli will not fly or reacts sluggishly, even after checking for proper setting of pitch and throttle, check the following items:
 - Plastic Parts
 - Bearings
 - Ball bearings
 - Rotor Blades
4. **Check for excess play or gaps between the surfaces, missing or broken parts, or binding or restricted movement.** It is important to check for main rotor balance before each flight. Operating the model when out of balance will cause excessive wear and premature failure of parts, possibly resulting in a dangerous situation.
5. **Control Arm Assembly:** Check regularly for cracked, worn, bent or binding control arms and pushrods. Smooth movement of control arms and linkages is required for stable, vibration free flight. **Swashplate:** Check for excess slop in the main ball where the main shaft rides on, and slop or looseness between the plastic and metal surfaces. Swashplate wear will result in poor stability and lack of control during flight. Replace as necessary.

FUSELAGE/CHASSIS

1. **Main Shaft Bearing:** Normal replacement interval for proper operation is between 60-100 flights. If flying 3D or extreme aerobatics often, inspect the bearing frequently and shorten the interval as necessary.
2. **One Way Bearing:** One way bearings have longer lifetimes. Failure is not common. To keep the one-way bearing in good operation, remove it and lubricate after every 50 flights. If the main drive gear is loose, you should replace the one-way bearing (part # HB6002)
3. **Drive Belt:** ALIGN uses only top quality, Japanese made stretch-proof belts. It is however, impossible to prevent the belt from stretching or wearing out. Check belt tension regularly, and check for the wear on the teeth. Replace as necessary.

LINKAGE RODS & CONNECTING PARTS

During assembly, take special care to keep the connecting parts in smooth operation, and avoid excess play or binding. Failure to do so will result in poor flight stability. The linkage rods and ends will break and wear due to normal usage, crashing, and poor maintenance and environment. Check for wear and proper operation regularly, replace as needed.

TAIL ROTOR SYSTEM

1. **Tail Rotor Control Set:** Check the tail rotor bearing regularly. If there is excess play or gaps replace immediately. Avoid any binding or improper contact on the tail components and bearings as this will cause excess wear and heat potentially melting or deforming the tail system.
2. **Tail Unit Assembly:** Avoid flying in tall grass or weeds. If grass or weed becomes lodged in the tail rotor unit, it will interfere with the operation, and cause the helicopter to lose control. Always check for foreign objects in the tail and clean them off immediately. Avoid using lubricants on the exposed surfaces of the model as it will attract and collect dirt and debris, and cause failure.
3. **Tail Rotor Housing:** Disassemble Tail rotor housing for cleaning and maintenance after every 50 flights. If the tail does not operate smoothly or shows any signs of stress or wear, please replace immediately.
4. **Tail Rotor:** Check the Tail Rotor blades regularly for damage, especially if the helicopter ever strikes the ground while flying, or after hard landings. Damaged Tail Rotor blades can induce vibration.

[Back](#) [Next](#)

Spare parts and tools



1set

HS1000
290 ABS Rotor blade



1set

HH3004-1
315 Wooden rotor blade

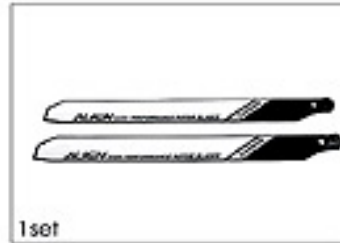

1set

HS1042
325 Carbon rotor blade



1set

HS1001-1
Main rotor holder

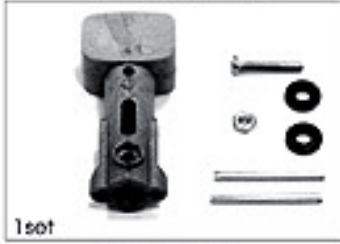

1set

HS1002
Main rotor housing set

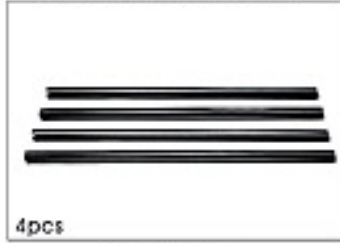

4pcs

HS1003
Feathering shaft



1set

HS1004-1
Flybar seesaw holder



1set

HS1005
Flybar paddle

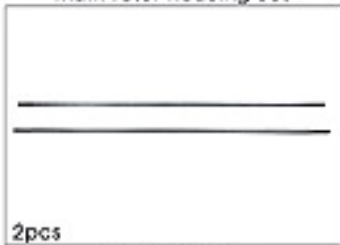

2pcs

HS1006
Flybar rod



1set

HS1007
Washout assembly



1set

HS1008
Swashplate set



1set

HS1009
Elevator arm holder



1set

HS1010-1
Collective pitch control arm

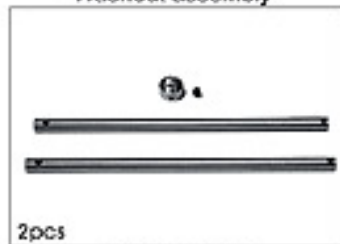

2pcs

HS1011-2
Main shaft



1set

HS1012-1
Main frame set



1set

HS1013-1
Tail drive gear assembly

221

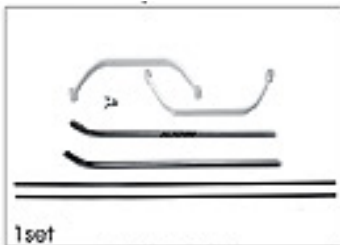

1set
HS1014-1
Landing skid set

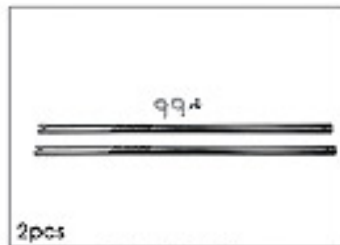

2pcs
HS1041
Tail boom

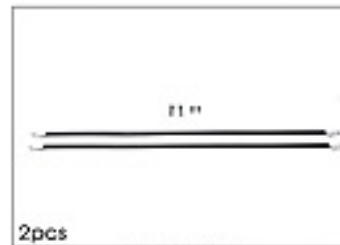

2pcs
HS1016
Tail boom brace

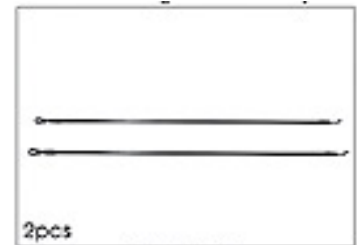

2pcs
HS1017
Tail linkage rod

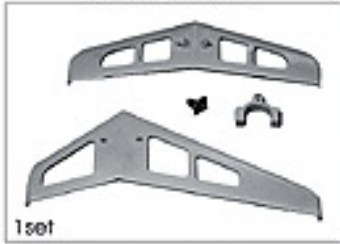

1set
HS1018
Vertical / horizontal stabilizer



1set
HS1019
Tail rotor blade set



1set
HS1020-1
Tail case



1set
HS1021
Tail rotor shaft set



1set
HS1022
Tail rotor control assembly



1set
HS1023-1
Tail holder set



1pc
HS1038
Drive belt

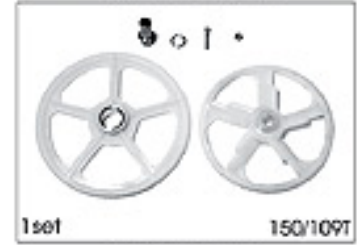

1set
HS1039-1
Main drive gear
150/109T



1set
HS1037
Canopy



1pc
HS1036
Main rotor fixing

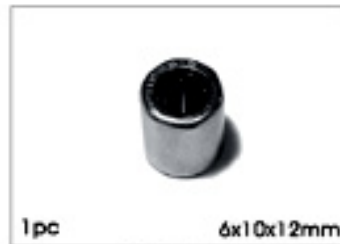

1pc
HS1026
One way bearing
6x10x12mm

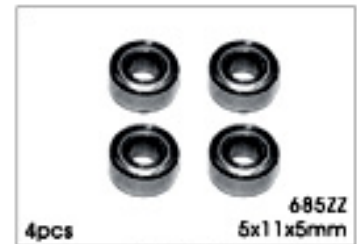

4pcs
HS1028
Bearings
685ZZ 5x11x5mm

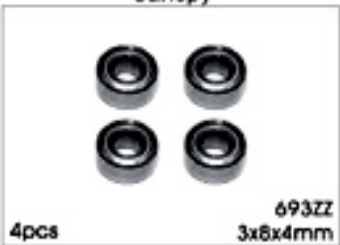

4pcs
HS1029
Bearings
693ZZ 3x8x4mm

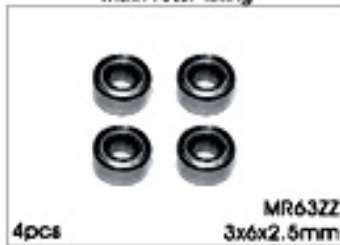

4pcs
HS1030
Bearings
MR63ZZ 3x6x2.5mm

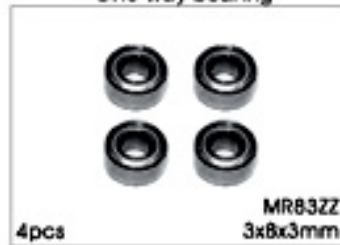

4pcs
HS1031
Bearings
MR83ZZ 3x8x3mm

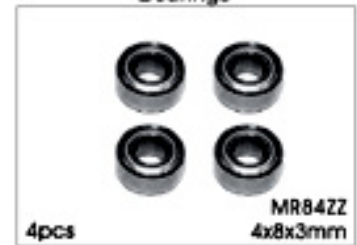

4pcs
HS1032
Bearings
MR84ZZ 4x8x3mm

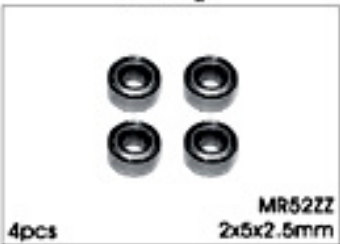

4pcs
HS1033
Bearings
MR52ZZ 2x5x2.5mm

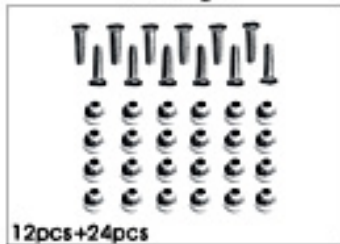

12pcs+24pcs
HS1027-1
Linkage ball

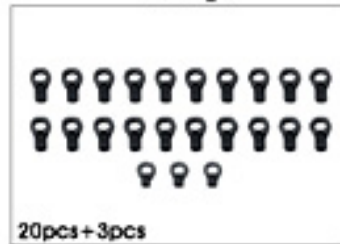

20pcs+3pcs
HS1050
Ball link

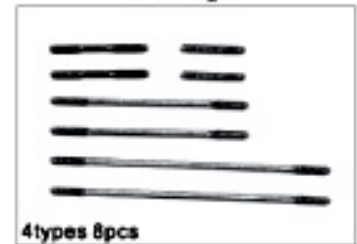

4types 8pcs
HS1034
Linkage rod

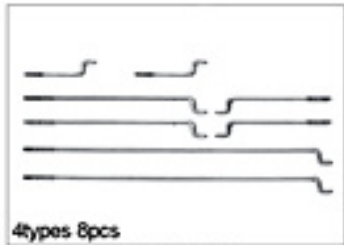

4types 8pcs

HS1035

Servo linkage rod



HZ015

Hardware bag



6pcs

HZ022

Landing skid nut

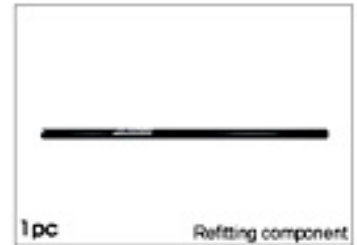

1pc

Refitting component

HZ019

Carbon tail boom(standard)



1pc

Refitting component

HS1043

Carbon tail boom(upgrade 347)



1set

Refitting component

HS1043

Vertical/Horizontal stabilizer(3k)



1set

Refitting component

HS1044

Main frame set(3k)

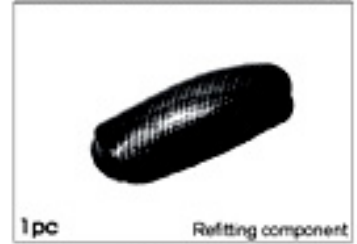

1pc

Refitting component

HS1045

Canopy cover(3K)



1set

Refitting component

HS1047

Tail rotor blade set(3k)



1set

Refitting component

HS1048

Main rotor holder & Housing set(3K)



1pc

Refitting component

HS1049

Canopy(3K)



1pc

Refitting component

HT1003

Drive belt(upgrade 397T)



2pcs

Refitting component

HZ017

Tail boom(upgrade 347)

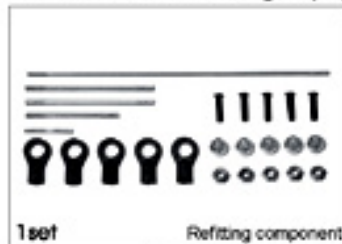

1set

Refitting component

HZ010

Servo linkage rod refitting components



4pcs

Option tool

HZ024

Hexagon screw driver



1set

Option tool

K10180A

Micro heli pitch gauge

[Back](#) [Back to instruction manual](#)